

HomeWorks®  
Technical Reference Guide  
International Edition (220-240 V)

Rev H





# Table of Contents

## **INTRODUCTION**

Introduction to HomeWorks® . . . . .	2.1
Features . . . . .	2.4

## **SYSTEM DESIGN**

<b>Design Overview</b> . . . . .	3.2
Centralised Design . . . . .	3.3
Localised Design . . . . .	3.4
Hybrid Design . . . . .	3.5
<b>Series Overview</b> . . . . .	3.6
4 Series System Layout . . . . .	3.8
8 Series System Layout . . . . .	3.9
4 Series System Wiring and Communication . . . . .	3.10
8 Series System Wiring and Communication . . . . .	3.12
System Specifications . . . . .	3.14

## **FRONT ROOM EQUIPMENT**

<b>Local Controls</b> . . . . .	4.1
Rania® RF . . . . .	4.2
Maestro® . . . . .	4.10
GRAFIK Eye® . . . . .	4.16
GRAFIK Integrale® . . . . .	4.22
<b>Keypads and Contact Closures</b> . . . . .	5.1
International seeTouch® . . . . .	5.4
Dual International <i>seeTouch</i> . . . . .	5.7
<i>seeTouch</i> . . . . .	5.9
European-style . . . . .	5.14
Slim Button . . . . .	5.17
Large Button . . . . .	5.18
Signature Series™ . . . . .	5.21
Architrave™ . . . . .	5.22
Engraving with Icons . . . . .	5.25
Wallbox Closure Interface . . . . .	5.26
Web Keypads . . . . .	5.28
Keypad Specifications, Addressing and Dimensions . . . . .	5.29

## **BACK ROOM EQUIPMENT**

<b>Power Modules and Remote Power Panels</b> . . . . .	6.1
Wallbox Power Module . . . . .	6.2
Remote Power Modules . . . . .	6.6
Module Interface . . . . .	6.12
Remote Power Panels	
Without Breakers . . . . .	6.16
With Breakers . . . . .	6.20
<b>Power Boosters and Interfaces</b> . . . . .	7.1
FDBI . . . . .	7.6
0-10 V Interface . . . . .	7.7
TVM Dimming Kit . . . . .	7.9
Ten Volt Module . . . . .	7.13
LUT-DMX . . . . .	7.14
Contact Closure Interface . . . . .	7.18
<b>Processors</b> . . . . .	8.1
8 Series Processors . . . . .	8.8
4 Series Processors . . . . .	8.12
<b>Low-voltage Enclosures</b> . . . . .	9.2
<b>Wireless Equipment</b> . . . . .	10.1
Hybrid Repeater . . . . .	10.2
Wireless Tabletop Keypads . . . . .	10.5
Transformers . . . . .	10.7
<b>Sivoia QED®</b> . . . . .	11.1
<b>Other Equipment</b> . . . . .	12.1
Link Extender . . . . .	12.2
Auxiliary Power Supplies . . . . .	12.4
Electric Low-voltage Transformers . . . . .	12.8
Wire Landing Board . . . . .	12.11
<b>Colours and Finishes</b> . . . . .	13.1





# Introduction

# Introduction to HomeWorks®

## The most powerful and most flexible lighting control system in the world

*HomeWorks*, the world's leading residential lighting control and integration system, provides simple, convenient control of all home lighting, as well as the ability to control motorised shades and curtains, and many other systems in a home. *HomeWorks* provides many benefits.

- Increased security
- Design and control flexibility
- Added convenience
- Improved aesthetics
- Energy savings

### **INCREASED SECURITY**

*HomeWorks* seamlessly integrates with home security systems. In the event of an alarm, interior lights turn on, illuminating a safe exit, while exterior lights flash, thereby drawing immediate attention.

*HomeWorks* provides security by allowing clients to turn all lights on instantly from a single button press.

*HomeWorks* makes a home safer by automatically turning on landscape and security lighting each night. A built-in astronomical timeclock intelligently adjusts for changing sunrise and sunset times throughout the year.

Every day, a *HomeWorks* system automatically records the home's lighting usage patterns. These patterns can be replayed when the home is unoccupied. This unique feature allows for a realistic simulation of activity that standard timers cannot provide.

### **DESIGN AND CONTROL FLEXIBILITY**

*HomeWorks* systems are very flexible. Solutions exist for residences of any size.

After the installation, keypads may be easily reconfigured to accommodate new control requirements.

### **ADDED CONVENIENCE**

Control any light in a home from any *HomeWorks* keypad. This eliminates the tedious task of walking around the home to set the right lighting for daily activities or special occasions.

# Introduction to HomeWorks®

## ***IMPROVED AESTHETICS***

*HomeWorks* gives clients the power to enhance the beauty of their home and decor with a variety of customised room and whole-house lighting scenes. One button press can dim the lights for a romantic dinner while another button press lights the house for a festive party.

Keypads provide a clean, elegant look on the wall by combining the functions of many standard switches and dimmers into a single control.

Lutron® combines a large selection of controls with an extensive array of colours and finishes. *HomeWorks* keypads are available with custom engraving. *seeTouch*® keypads provide a unique backlighting feature whereby engraving is readable in the dark.



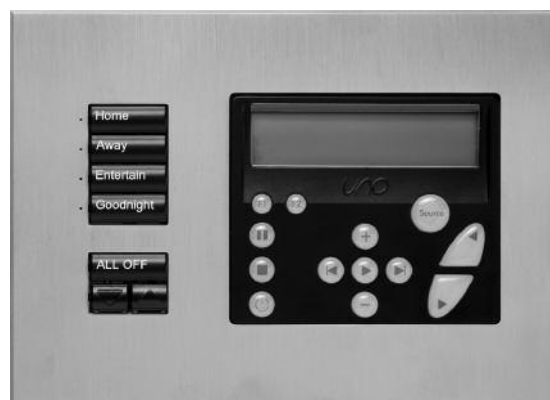
***International seeTouch®***



***seeTouch tabletop keypad***



***seeTouch keypad***



***Custom faceplates - combination of seeTouch and Russound® audio control***

# Features

## **LUTRON QUALITY**

Lutron® has been the world leader in lighting controls since inventing the solid-state dimmer in 1961. All *Lutron* products are designed and manufactured to the highest quality standards. All *HomeWorks*® systems are covered by an 8-year limited warranty. *Lutron* was one of the first 20 companies in the US to earn the ISO 9001 international quality certification, and today *Lutron* is ISO 9001:2000 certified.

## **FAIL-SAFE OPERATION**

*HomeWorks* local lighting controls and GRAFIK Eye® preset local lighting controls remain fully functional even in the unlikely event communication to the processor is interrupted. Dimming panels also have manual override capabilities, which can be activated from dedicated switches located anywhere in the home.

## **POWER-FAILURE MEMORY**

All *HomeWorks* components are designed with 10-year power-failure memory. If power is interrupted temporarily and restored, lights will automatically return to the levels to which they were set prior to the power outage.

## **SECURITY**

Connect *HomeWorks* to a security system to activate lights in case of an alarm. Selected lights will turn on to a predetermined security level, while others flash repeatedly to attract attention. Security mode may also be activated manually from a keypad. When security mode is deactivated, the lighting returns to the original levels set before security mode was activated.

## **AESTHETIC CONSISTENCY**

*HomeWorks* keypads and local lighting controls complement each other with matching colours, styles, and finishes. Elegant faceplates can also be customised to match a home's paint, wallcoverings, or decor.

## **ENERGY SAVINGS**

The *HomeWorks* system makes it easier than ever to consume less. Using *Lutron* dimmers not only extends lamp life but can reduce your average lighting consumption by up to 40%. With built in green features such as scene Rollback and load trimming, your home can be programmed to intelligently manage its lighting by turning off unused circuits and trimming power used on other circuits during peak hours.

Your home has different lighting needs during the day versus the night. With *HomeWorks*, we can make sure you have the perfect lighting at anytime without wasting energy on unnecessary lights.

# Features

## **ASTRONOMICAL TIMECLOCK**

HomeWorks® can automatically trigger events at specific times of the day or at times relative to sunrise or sunset. Program multiple schedules allowing for different timeclock events on weekdays, weekends, holidays, etc. Enable or disable timeclock schedules from any keypad. Additionally, any timeclock event can be programmed using conditional logic, so the event will occur only if a specified condition is met.

## **VACATION MODE**

HomeWorks constantly monitors and records the state of all lighting in a home. When vacation mode is activated, the system plays back these events, providing a realistic appearance of activity while the home is unoccupied. The system can be programmed to record the last day's, the last week's, or the last two weeks' activities.

## **INTEGRATION**

HomeWorks has been designed to integrate with audio, video, and other systems in a home. A typical application includes control of an audio system from buttons on a HomeWorks Keypad. Interface the system with other equipment using contact closure inputs and outputs, infrared inputs, RS-232 serial communication, and ethernet.

## **CONDITIONAL LOGIC**

HomeWorks provides the capability to activate events only if specific conditions are met. For example, program driveway sensors to turn on exterior lighting only if it is dark. A single "dining" button could set different lighting and music for breakfast, lunch, and dinner.

## **PROGRAMMING FLEXIBILITY**

HomeWorks keypads can be customised to meet customers' changing needs. Each keypad button may be programmed to activate any of the lights in the system. Keypad buttons may also be programmed to control audio, video, shades, curtains, and other integrated systems.

## **BACKLIT KEYPADS**

HomeWorks seeTouch® and Signature Series™ keypads have backlighting so that the button labels can easily be read in a dark room.

## **REMOTE CONNECTION AND CONTROL**

The HomeWorks system features the ability to support a remote connection by utilising the home's existing Ethernet network. Once configured by a professional, the system can be updated and even monitored from any location around the world. With such flexibility, you can now take peace of mind with you as the HomeWorks system even integrates with several mobile devices such portable phones and computers.



# System Design

# Design Overview

System design begins with drawings of the home. The system design depends on customer requirements and the home's lighting (load types, wattages and quantity). HomeWorks® has multiple system design options:

## **CENTRALISED DESIGN**

Centralised designs place dimming equipment in remotely mounted panels. All lights are controlled from keypads, providing maximum flexibility, while minimising the number of controls on the wall.

## **LOCALISED DESIGN**

Localised designs place dimming components in or near the room they are controlling. Local dimmers provide simple and easy control for small rooms. In large rooms where several local dimmers would be unsightly, locally mounted wallbox dimming modules are used instead. Wallbox dimming modules can be placed in nearby closets, cupboards, and utility rooms, and controlled from keypads in the room.

## **HYBRID DESIGN**

Hybrid designs combine the benefits of both centralised and localised designs. This maximises ease of use, while minimising excessive controls on the walls.



# Centralised Design

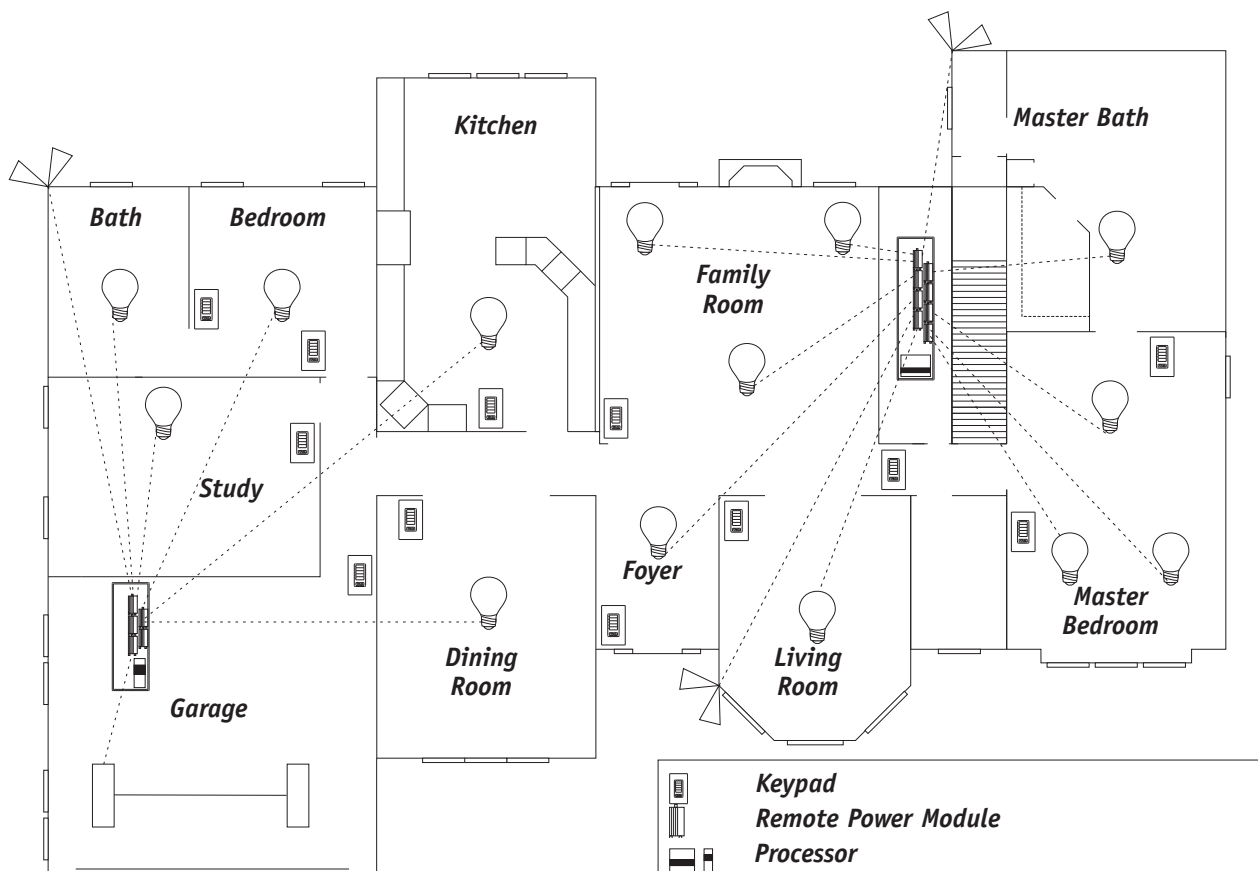
A centralised design uses Remote Power Modules to control all lighting loads. The Remote Power Modules are mounted in power panels, located in equipment rooms or electrical closets. The clients control the lights from keypads, providing maximum flexibility while minimising the number of controls on the wall. Keypads have the ability to perform any function from control of a single light to control of every light.

Remote Power Modules, located in power panels support large loads and a wide range of load types including incandescent, magnetic low-voltage, electronic low-voltage and neon/cold cathode. Remote Power Modules can also provide direct control of AC motors for shades, draperies, and curtains and other non-lighting equipment such as exhaust fans and pumps.

Each power panel has manual override control providing “fail-safe” operation in the unlikely event communication to the processor is interrupted.

## **CENTRALISED DESIGN SUMMARY:**

- Minimises the number of controls on the wall
- Direct control of AC motors
- Maximum control flexibility
- Minimises need for Power Boosters or interfaces
- Manual override control provides “fail-safe” operation



# Localised Design

A localised design uses local lighting controls (Rania® RF dimmers, Maestro® dimmers and switches, Wallbox Power Modules, and GRAFIK Eye® preset controls) to dim lighting loads. Local dimmers provide simple and easy to use control. In areas with several lights, remotely mounted Wallbox Power Modules are used instead. The Wallbox Power Modules are placed in nearby closets, cupboards, and utility rooms.

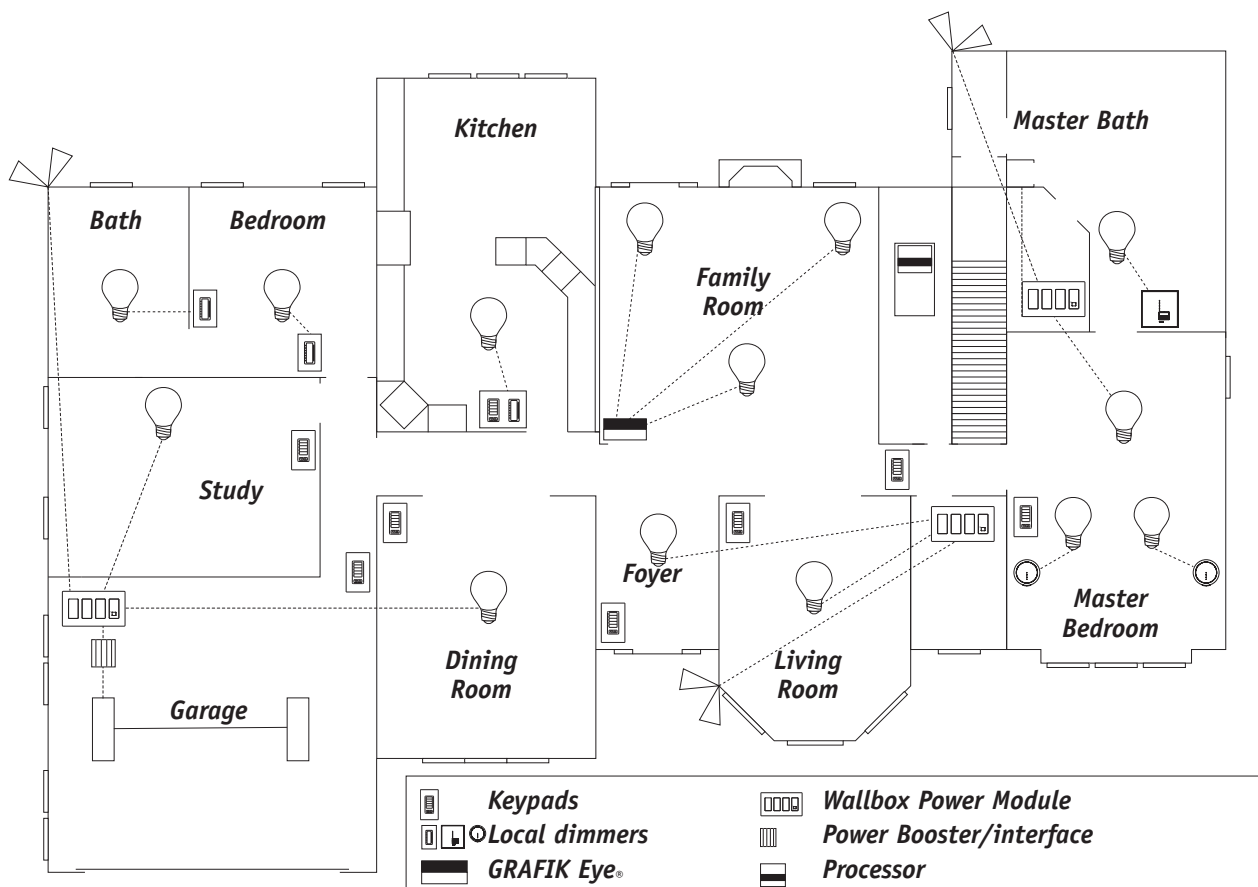
Keypads provide control of Wallbox Power Modules, as well as control of *GRAFIK Eye* and *Maestro* dimmers throughout the home. In this design, keypads are typically installed in locations such as entryways, master bedrooms, and key entertaining rooms.

Localised dimming components provide clients with “fail-safe” operation. If communication to the processor is interrupted, the local lighting controls continue to operate as normal.

Rooms of the house that have been pre-wired for local lighting control can be easily added to the system at a later date. This is ideal for the client who wants to start with a basic system and expand it later.

## **LOCALISED DESIGN SUMMARY:**

- Easy to use controls
- “Fail-safe” operation
- Pre-wire compatible



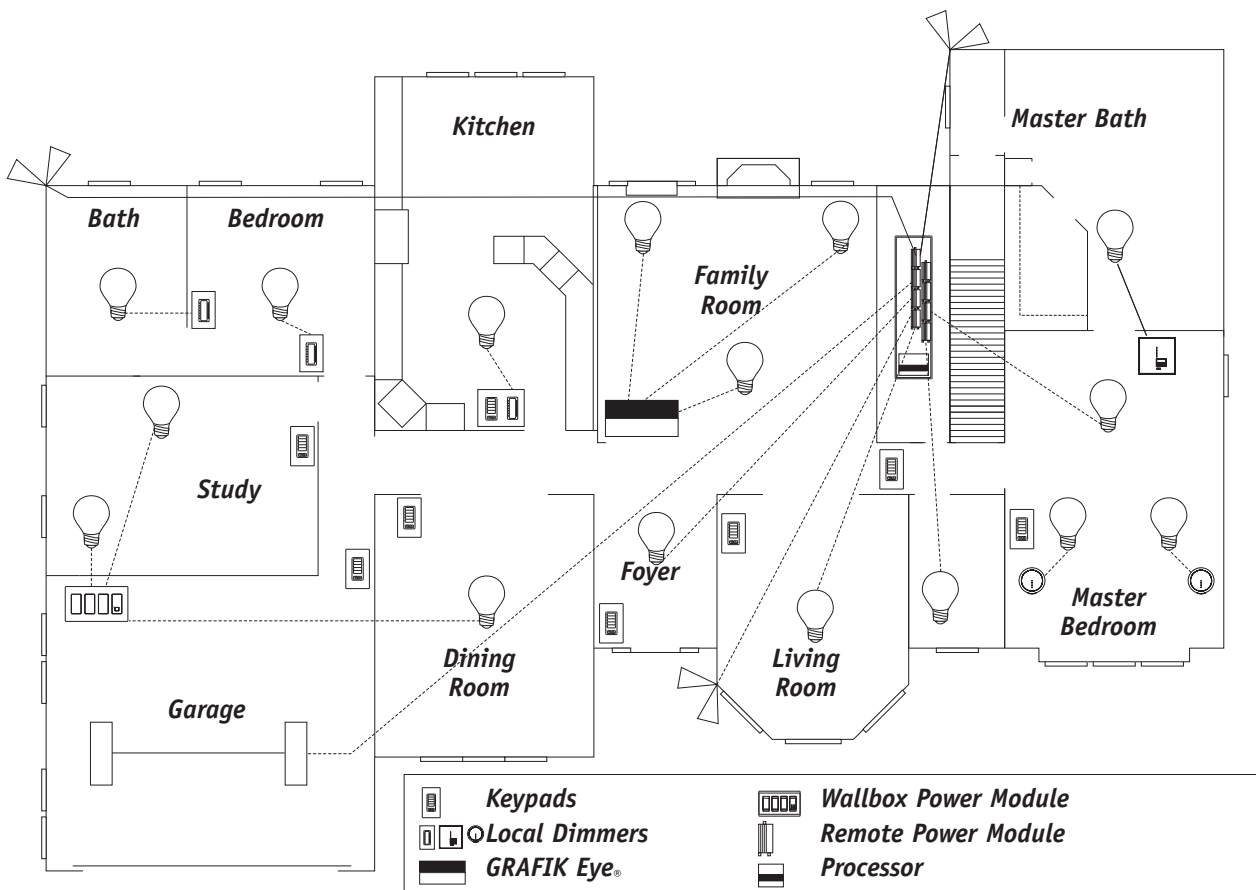
# Hybrid Design

A hybrid design for HomeWorks® combines the benefits of both centralised and localised designs. Typically, local lighting controls are used in smaller rooms where simple controls are desired. In larger rooms, lighting loads are typically wired to remote dimming components. Keypads are placed throughout the house, providing control wherever it is desired.

In this design, areas of the house that have been pre-wired can be easily added to the system at a later date. This is ideal for the client who would like to start with a basic system and then expand it later.

## ***HYBRID DESIGN SUMMARY:***

- Easy to use controls
- Direct control of AC motors
- Maximum control flexibility
- Minimises need for Power Boosters or interfaces
- “Fail-safe” operation
- Pre-wire compatible



# Series Overview

## **8 SERIES**

The 8 series is used when a centralised or hybrid system design is desired. It provides the most flexibility in design and integration capabilities. The 8 series has components which support higher wattage loads, the widest range of load types, and direct AC motor control.

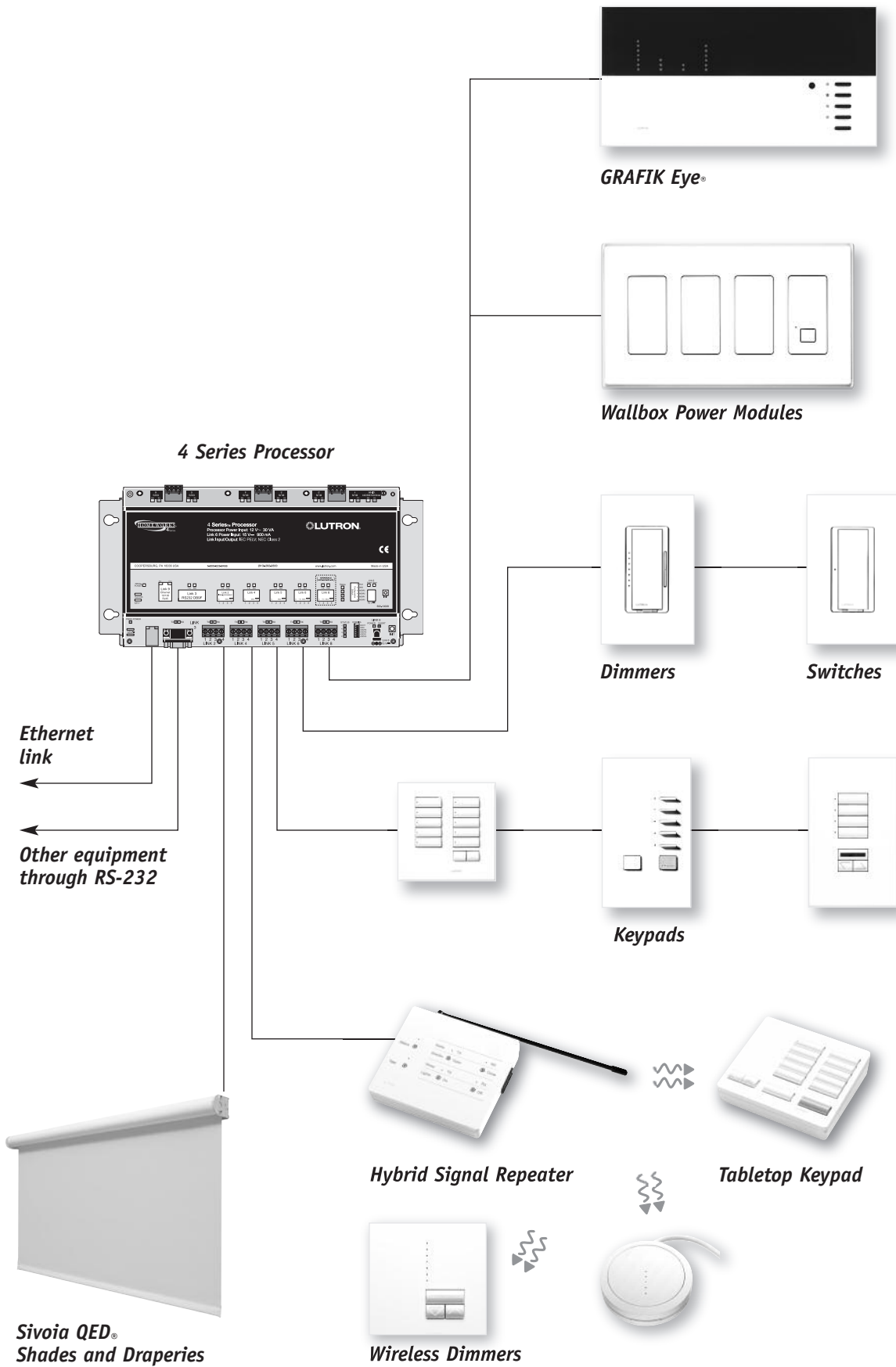
## **4 SERIES**

The 4 series is used when a localised system design is desired. The 4 series is usually the lowest cost solution but sometimes requires Power Boosters and interfaces.

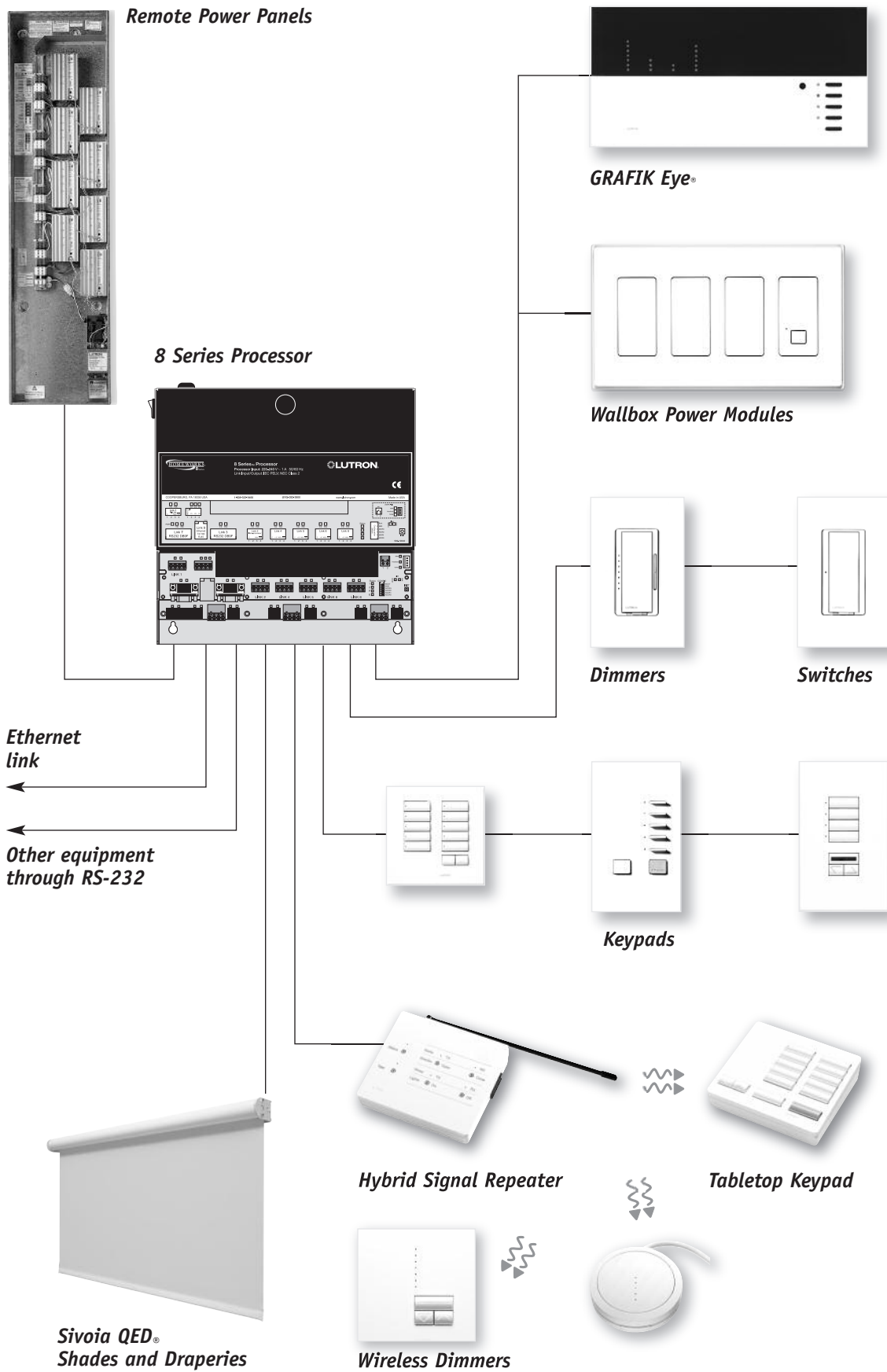
		<b><i>8 series</i></b>	<b><i>4 series</i></b>
<b><i>System designs supported</i></b>	centralised	yes	no
	localised	yes	yes
	hybrid	yes	yes
<b><i>Dimming capability</i></b>	dimming panels	yes	no
	Wallbox Power Modules	yes	yes
	local lighting controls	yes	yes
<b><i>Control capability per processor</i></b>	typical zone count	20 to 256 (256 maximum)	20 to 96 (256 maximum)
	typical keypad count	5 to 40 (96 maximum)	5 to 20 (96 maximum)
<b><i>Integration capability</i></b>	motor control	direct	thru interface
	RS-232 integration	2 ports / processor	1 port / processor
	ethernet	1 port / processor	1 port / processor
	input and output contact closures	yes	yes
	Sivoia QED®	yes	yes
<b><i>Wireless capability</i></b>	signal repeaters	5 per processor	5 per processor
	tabletop keypads	32 per system	32 per system
	wireless dimmers	64 per processor	64 per processor



# 4 Series System Layout

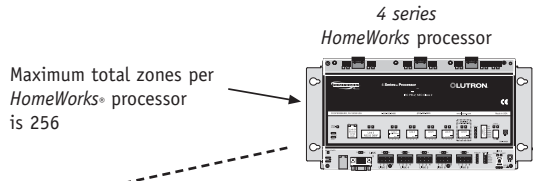


# 8 Series System Layout

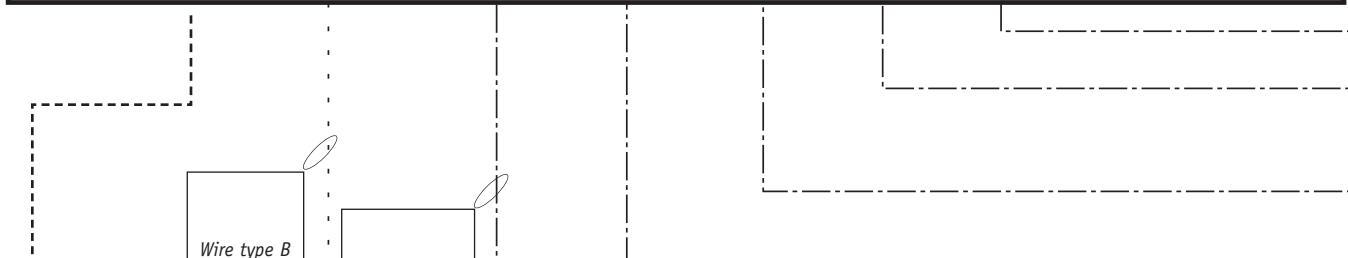
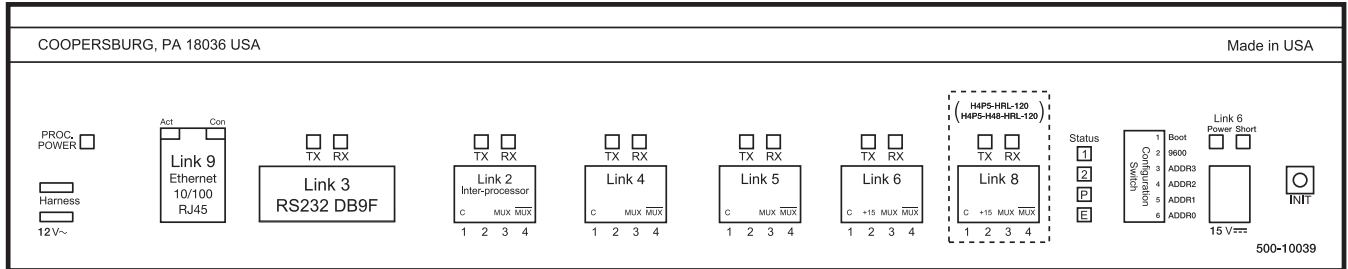


SYSTEM DESIGN

# 4 Series System Wiring and Communication



Enlarged view of processor Label



Connect to other devices and home networks using standard ethernet cable.

Wire type B maximum 15 m (50 feet) total point-to-point

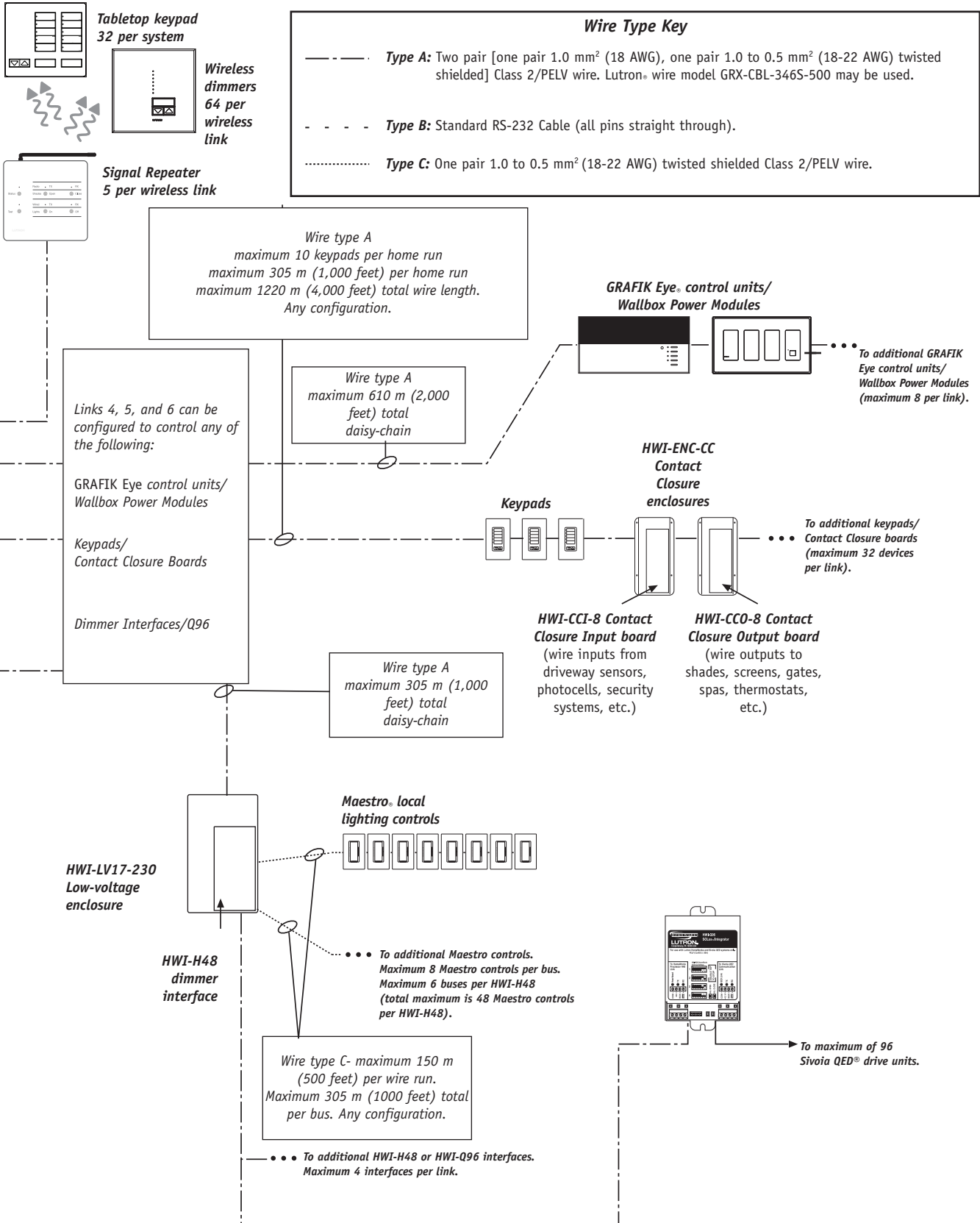
Wire type A maximum 305 m (1,000 feet) total daisy-chain

To additional processors. 16 maximum per HomeWorks system.

Connect to audio, home automation, and other devices controlled using RS-232.

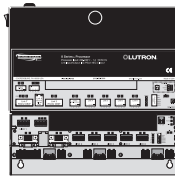
SYSTEM DESIGN





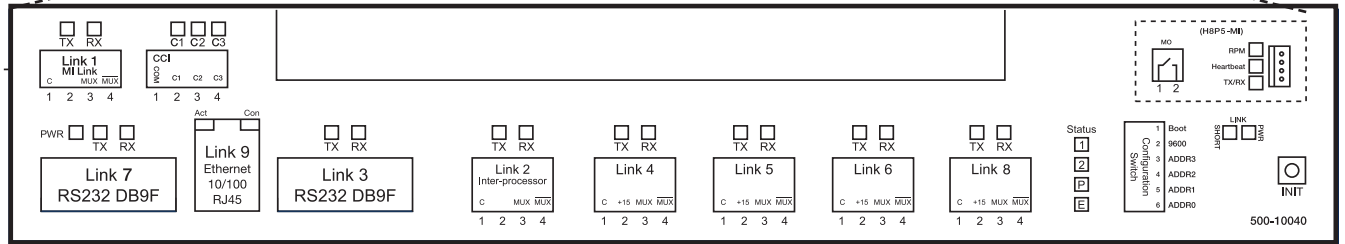
# 8 series System Wiring and Communication

Maximum total zones per HomeWorks® processor is 256



8 series HomeWorks processor

Enlarged view of processor Label



Connect to other devices and home networks using standard ethernet cable.

Wire type A maximum 305m (1,000 feet) total daisy-chain

Wire type B maximum 15m (50 feet) total point-to-point

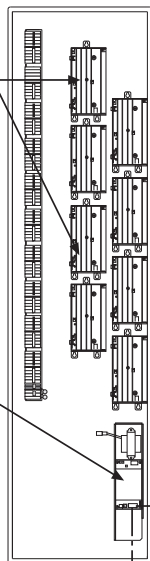
To additional processors. 16 maximum per system.

Connect to audio, home automation, and other devices controlled using RS-232.

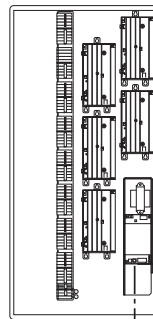
Wire type A maximum 305 m (1,000 feet) total daisy-chain

HWI-PNL-8-CE Remote Power Panel

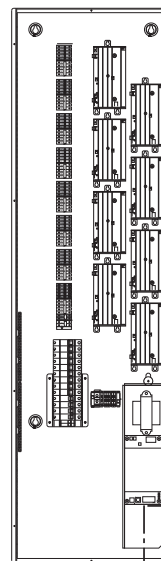
Remote Power Modules



HWI-PNL-5-CE Remote Power Panel

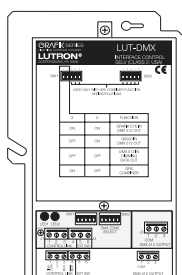


PBK8-40-13-10-CE or PBK8-40-10-CE Remote Power Panels

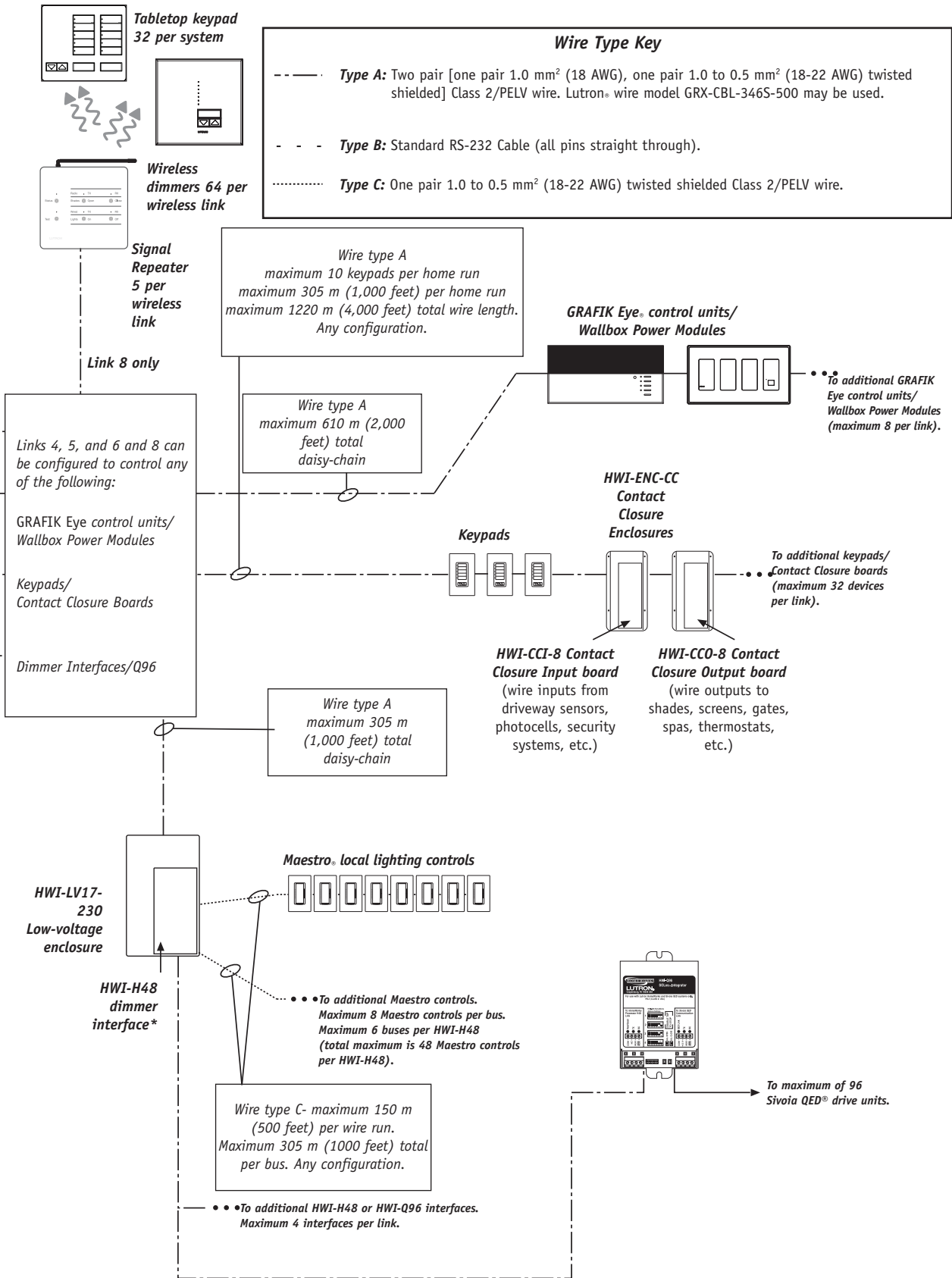


To additional Module Interfaces. Maximum per Module Interface Link is 16

LUT-DMX



HWI-MI-230 Module Interface



# System Specifications

## **Maestro® local lighting controls capacities**

Maximum number of <i>Maestro</i> Local lighting controls per dimmer interface (H48) bus	8
Number of buses per H48	6
Maximum number of <i>Maestro</i> Local lighting controls per H48	48
Maximum number of H48 and Q96 interfaces per processor link	4
Maximum number of <i>Maestro</i> local lighting controls per processor H48 link	192
Maximum number of H48 links per processor	1
Maximum number of <i>Maestro</i> Local lighting controls per processor	192
Maximum number of processors per system	16
Maximum number of <i>Maestro</i> Local lighting controls per system	3,072

## **Wired Keypad capacities**

Maximum number of devices per keypad link	32
Maximum number of keypad links per processor	3
Maximum number of keypads per processor	96
Maximum number of processors per system	16
Maximum number of keypads per system	1,536

## **Wireless capacities**

Maximum number of Hybrid signal repeaters per processor	5
Maximum number of tabletop keypads per system	32
Maximum number of wireless dimmers per wireless link	64

## **Sivoia QED® capacities**

Maximum number of H48 and QED links per processor	1
Maximum number of H48 and QED interfaces per processor	4
Maximum number of <i>Sivoia QED</i> drives per Q96 interface	96
Maximum number of <i>Sivoia QED</i> drives per system	4096

# System Specifications

## 8 series processor communication link specifications

Link type	Maximum per processor	Baud rates	Wiring configuration	Termination required
Module Interface	1	125 K	daisy-chain	yes, at last MI on link <sup>1</sup>
inter-processor	1	125 K	daisy-chain	yes, at both ends of link <sup>1</sup>
GRAFIK Eye <sup>®</sup> /WPM	3	31.25 K	daisy-chain	no
RS-232	2	9600-115.2 K	point-to-point	no
keypad	3	10.42-41.67 K	any	no
H48 and Q96 interface	1	125 K	daisy-chain	yes, at both ends of link <sup>1</sup>
Hybrid Signal Repeater	1	125 K	daisy-chain	no

<sup>1</sup> Terminators required if total cable length exceeds 15 m (50 feet).

## 4 series processor communication link specifications

Link type	Maximum per processor	Baud rates	Wiring configuration	Termination required
inter-processor	1	125 K	daisy-chain	yes, at both ends of link <sup>1</sup>
RS-232	1	9600-115.2 K	point-to-point	no
keypads	3	10.42-41.67 K	point-to-point	no
GRAFIK Eye/WPM	3	31.25 K	daisy-chain	no
H48 and Q96 interface	1	125 K	daisy-chain	yes, at both ends of link <sup>1</sup>
Hybrid Signal Repeater	1	125 K	daisy-chain	no

<sup>1</sup> Terminators required if total cable length exceeds 15 m (50 feet).

### Remote Power Module (RPM) capacities

Number of zones per RPM	4
Maximum number of RPMs per Module Interface (MI)	8
Maximum number of MIs per MI link	16
Maximum number of MI links per processor (8 series only)	1
Maximum number of RPMs per processor (8 series only)	128
Maximum number of RPM zones per processor (8 series only)	256
Maximum number of processors per system	16
Maximum number of RPMs per system	2,048
Maximum number of RPM zones per system	4,096

### GRAFIK Eye/WPM capacities

Maximum number of GRAFIK Eye control units/WPM per GRAFIK Eye link	8
Maximum number of GRAFIK Eye accessory controls per GRAFIK Eye link	15
Maximum number of GRAFIK Eye links per processor	3
Maximum number of GRAFIK Eye control units/WPM per processor	24
Maximum number of GRAFIK Eye accessory controls per processor	45
Maximum number of processors per system	16
Maximum number of GRAFIK Eye control units/WPM per system	384
Maximum number of GRAFIK Eye accessory controls per system	720





# Local Controls

# Rania® RF Local Lighting Controls

## **LOCAL LIGHTING CONTROLS**

Rania RF local lighting controls, function like standard wall and lamp dimmers, and can be controlled as part of the whole-house lighting control system. Local lighting controls are useful in locations where single circuits of lighting need to be dimmed. Rania RF dimmers have advanced features such as fade-on/fade-off, long fade-to-off, and rapid full-on. In addition, the local control may be programmed similar to a keypad button press with single and double tap functions, turning multiple lights on or off. Rania RF local lighting controls install in single-pole, 2-way, or 3-way applications.

## **ACCESSORY CONTROLS**

Remote dimmers (HI-RD) are used in combination with a Rania RF local lighting control to provide 2-way and 3-way control. As many as nine (9) HI-RD can be used with a single Rania RF dimmer.

## **FINISHES AND COLOURS**

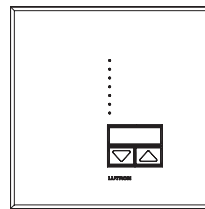
Rania RF local lighting controls are available in a variety of architectural colours and finishes. See section 13.

### **IMPORTANT NOTE:**

Regulations for products with radio frequency change from country to country. Therefore, HomeWorks® products with radio frequency are not available in all countries.

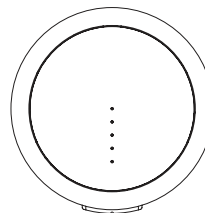
HomeWorks products with radio frequency have been developed around two different frequencies—434 MHz and 868 MHz. You should use the HomeWorks software to select the appropriate frequency for the regulations of your country.

Contact Lutron® for further assistance.



## **WALL DIMMER** **LOAD RATINGS**

**HRI-45D1-1x** will dim single incandescent, magnetic low-voltage or electronic low-voltage circuit up to 450 W/VA.



## **LAMP DIMMER** **LOAD RATINGS**

**HRT-3LD-1x** will dim single incandescent/halogen or low-voltage lamp up to 300 W/VA.

## **INSTALLATION NOTE**

Recommended back box depth is 35 mm. Use either EBB-15-RD (round back box) or EBB-15-SQ (square back box, quantity 15).

## **COMMUNICATION TO SYSTEM**

The Rania RF dimmer and the Rania RF lamp dimmer communicate to the HomeWorks® system through a hybrid repeater interface. A hybrid repeater (model HR-REP-868) must be connected to the system in order to control the RF dimmers.

All RF dimmers must be located within 9 m of a hybrid repeater. One processor can control up to 64 Rania RF dimmers. See figure 1 on page 10.2.



# Rania® RF Wall Dimmer

## ***MODEL # HRI-45D1-1F AND HRI-45D1-1I***

*Rania* RF dimmers function like standard wall dimmers, and can be controlled as part of the whole-house lighting control system. *Rania* RF wall dimmers have advanced features such as fade-on/fade-off, long fade-to-off, and rapid full-on. In addition, the local control may be programmed similar to a keypad button press with single and double tap functions, turning multiple lights on or off. *Rania* RF local lighting controls install in single-pole, 2-way, or 3-way applications.

## ***FINISHES AND COLOURS***

*Rania* RF wall dimmers are available in a variety of architectural colours and finishes. See section 13.

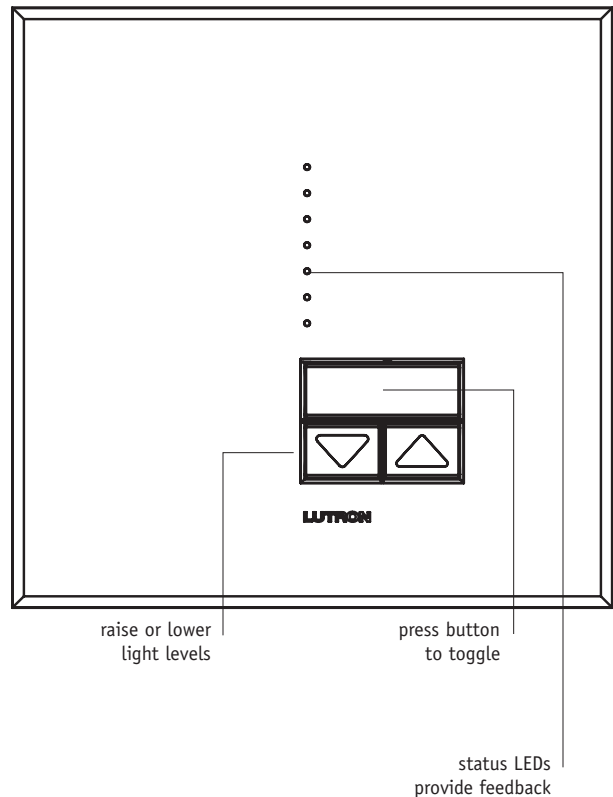
## ***DIMMING CONTROL LOAD RATINGS***

HRI-45D1-1X will dim single incandescent, magnetic low-voltage or electronic low-voltage circuit up to 450 W/VA.

## ***COMMUNICATION TO SYSTEM***

The *Rania* RF dimmer communicates to the HomeWorks® system through a hybrid repeater interface. A hybrid repeater (model HR-REP-868) must be connected to the system in order to control the RF dimmers.

All RF dimmers must be located within 9 m of a hybrid repeater. One processor can control up to 64 *Rania* RF dimmers. See figure 1 on page 10.2.



# Rania® RF Local Lighting Controls

<b>Rania RF local lighting controls</b>	
Models	HRI-45D1-1F-: 450 W dimming control with frameless faceplate. HRI-45D1-1I-: 450 W dimming control with framed insert faceplate HI-RD-F-, HI-RD-I-: remote dimmer.
Input voltage	220-240 V ~ 50 Hz
Regulatory approvals	CE
Environment	Ambient temperature: 0 °C to 40 °C (32 °F to 104 °F) Ambient humidity: 0-90% humidity, non-condensing. Indoor use only.
Addressing	Via the HomeWorks® utility using unique device serial numbers. Units must be installed prior to addressing. Counts as 1 of 64 addresses on a HomeWorks RF dimmer link. The device may be addressed without removing it from the wall.
ESD protection	Meets or exceeds the IEC 61000-4-2 standard.
Surge protection	Meets or exceeds ANSI/IEEE standard c62.41.
Diagnostics	LEDs provide diagnostics for troubleshooting.
Fail-safe operation	If communication with the processor is interrupted, all Rania RF controls will still provide local control.
Dimensions	See figures 1, 2, 3 page 4.5.
Mounting	Controls mount in round or square backbox, 35 mm deep.
Ganging	When multiple HomeWorks RF controls are located in a single wallbox, the control must be derated. See page 4.6.
Accessory controls	Use only Lutron® HomeWorks Rania remote dimmers (HI-RD); mechanical 2- or 3-way switches will not work. Up to 9 HomeWorks Rania remote dimmers may be used with one HomeWorks Rania dimmer.
<b>HRI-45D1-1x dimming control</b>	
Load types <sup>1</sup>	Incandescent, magnetic or electronic low-voltage, tungsten halogen. Note: You cannot mix magnetic and electronic low-voltage loads on the same control.
Maximum load	single-gang: 450 W/VA multiple gang: 350 W/VA
Minimum load	50 W/VA
Line-voltage wiring	See figures 5, 6 and 8, pages 4.6 and 4.7. Standard single-pole, 2-way, and 3-way wiring.
Frequency	868 MHz
<b>HI-RD • 2- or 3-way Remote Dimmer</b>	
For use with	HRI-45D1-1x
Maximum load	See local lighting control.
Minimum load	See local lighting control.
Line-voltage wiring	See figure 6, 7 and 8, page 4.7. Standard single-pole, 2-way, and 3-way wiring.

(1) To reduce the risk of overheating and possibly damaging other equipment, do not install HRI-45D1-1x to control receptacles, motor-operated appliances, or fluorescent lighting.

# Rania® RF Local Lighting Controls

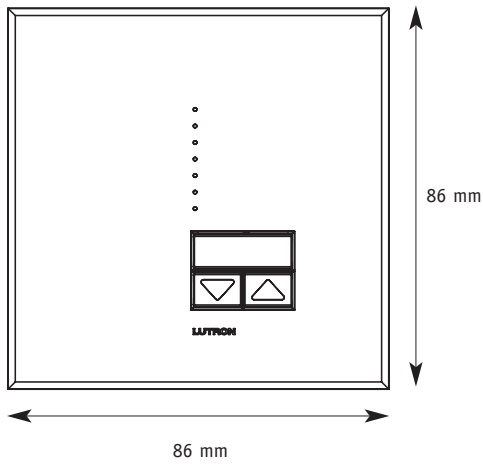


Figure 1 – front view dimensions

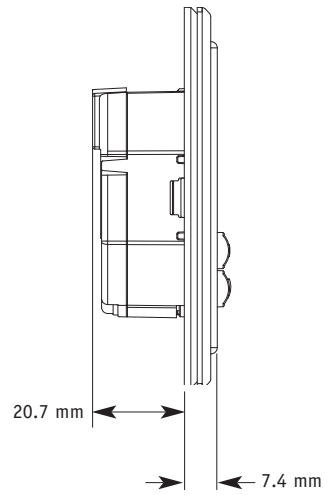


Figure 2 – side view dimensions

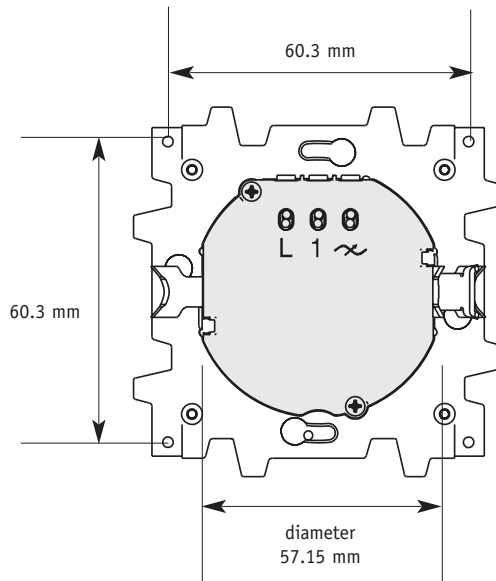
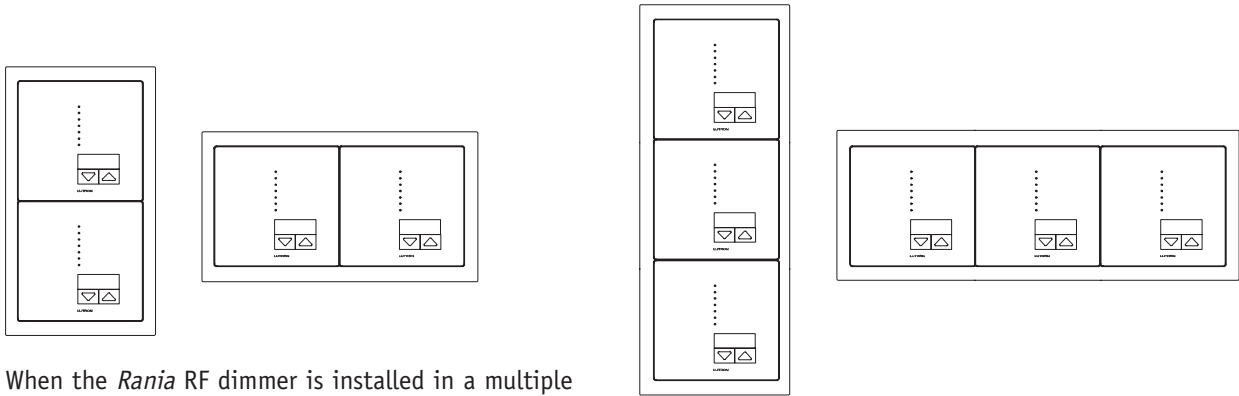


Figure 3 – back view dimensions

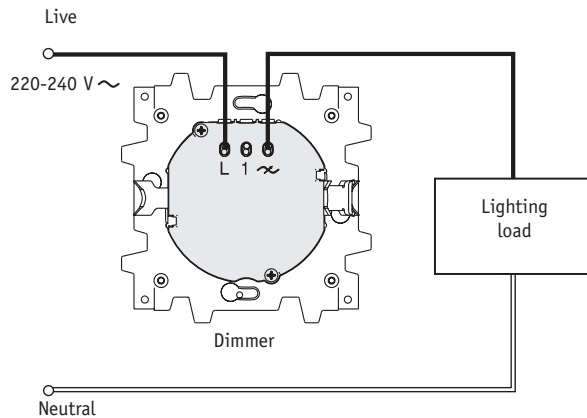
FRONT ROOM EQUIPMENT

# Rania® RF Local Lighting Controls

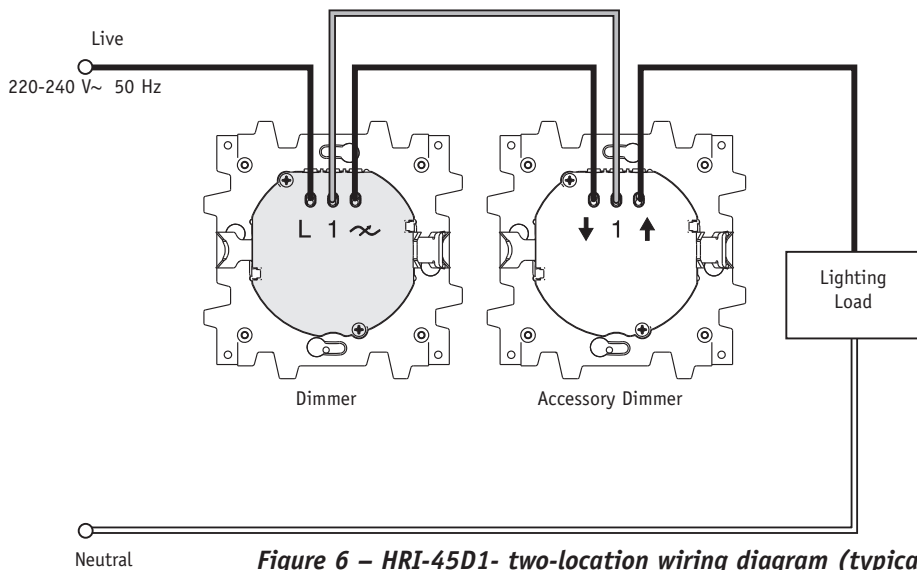


When the *Rania* RF dimmer is installed in a multiple gang configuration, the maximum rating decreases to 350 W/VA.

**Figure 4 – multiple gang configurations**



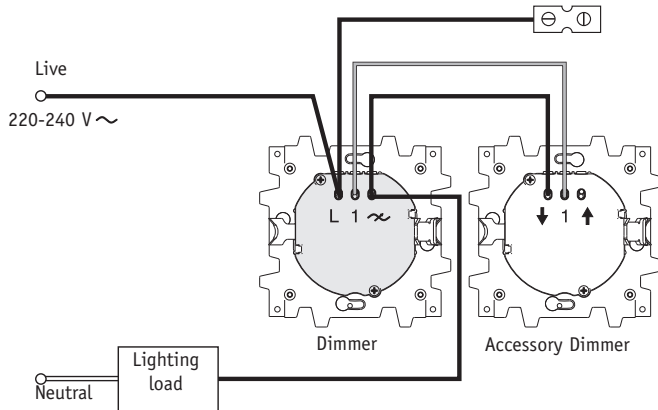
**Figure 5 – HRI-45D1-1x single-location wiring diagram**



**Figure 6 – HRI-45D1- two-location wiring diagram (typical in EU)**

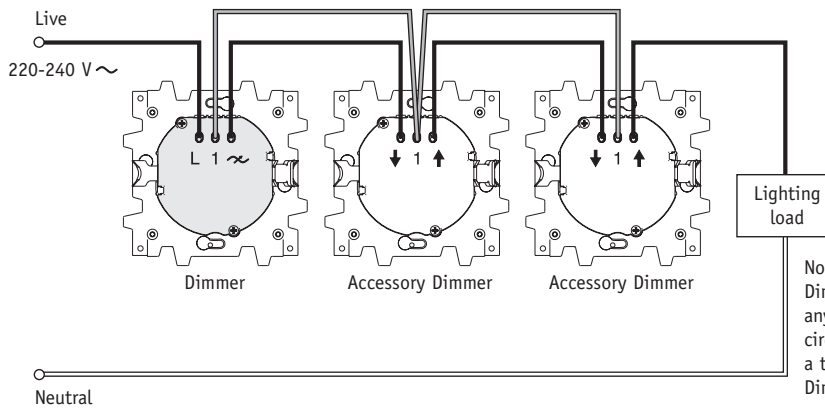
Note:  
Dimmer can replace any switch in the circuit. Connect up to a total of 9 Accessory Dimmers.

# Rania® RF Local Lighting Controls



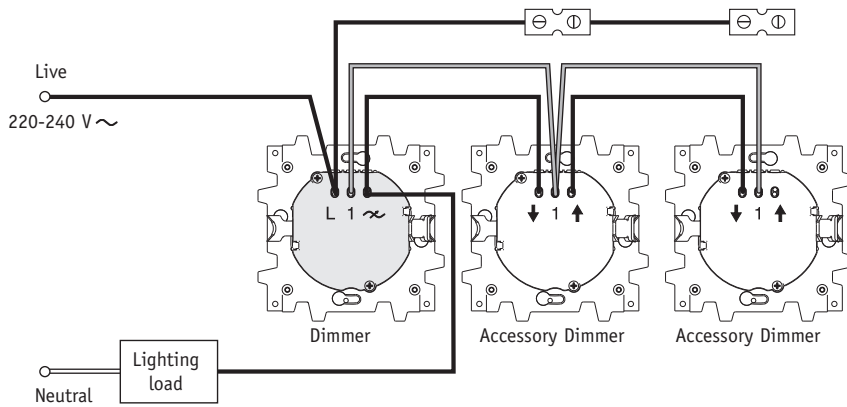
Note:  
Dimmer can replace  
any switch in the  
circuit. Connect up to  
a total of 9 Accessory  
Dimmers.

**Figure 7 – two-location wiring diagram (typical in UK)**



Note:  
Dimmer can replace  
any switch in the  
circuit. Connect up to  
a total of 9 Accessory  
Dimmers.

**Figure 8 – Multi-location installation:  
Dimmer line side (typical in EU)**



Note:  
Dimmer can replace  
any switch in the  
circuit. Connect up to  
a total of 9 Accessory  
Dimmers.

**Figure 9 – Multi-location installation:  
Dimmer line side (typical in UK)**

FRONT ROOM EQUIPMENT

# Rania® RF Lamp Dimmers

## **MODEL # HRT-3LD-1U AND HRT-3LD-1U**

Rania RF lamp dimmers allow table and floor lamps to be included in the HomeWorks® lighting control system. Each RF lamp dimmer controls one table or floor lamp. Simple to install, RF lamp dimmers are plugged into any standard wall outlet. Lamp dimmers can be controlled from any HomeWorks keypad in the home as well as from touch screens, universal remotes, and home automation controls.

RF lamp dimmers include advanced features such as fade-on/fade-off, long fade-to-off, and rapid full-on. The local control may be programmed like a keypad button press with single and double tap functions.

## **FINISHES AND COLOURS**

RF Lamp dimmers are available in Arctic White (AW) and MICA (MC).

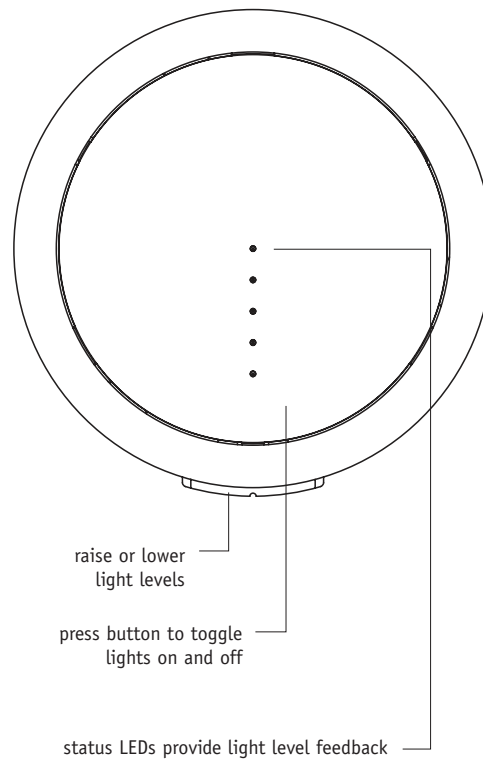
## **DIMMING CONTROL LOAD RATINGS**

HRT-3LD-1x controls a single incandescent/halogen or low-voltage lamp up to 300 W/VA.

## **COMMUNICATION TO SYSTEM**

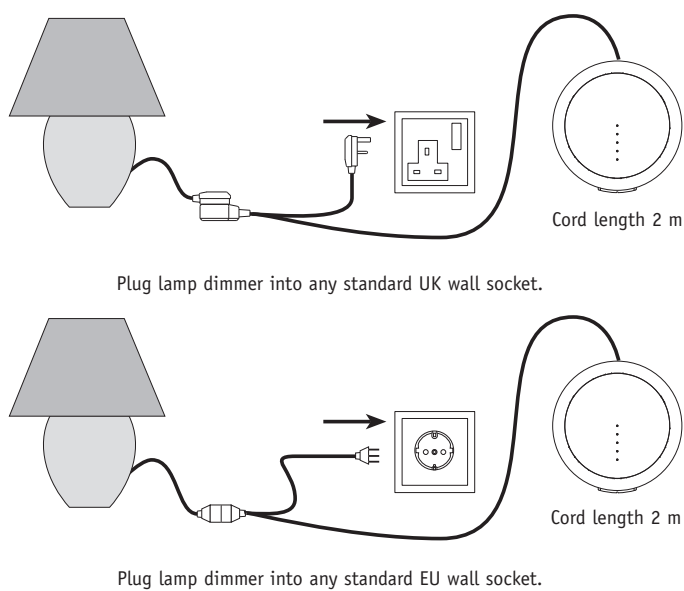
The Rania RF dimmer and the Rania RF lamp dimmer communicate to the HomeWorks system through a hybrid repeater interface. A hybrid repeater (model HR-REP-868) must be connected to the system in order to control the RF dimmers. See page 10.3.

All RF dimmers must be located within 9 m of a hybrid repeater. One processor can control up to 64 RF Rania dimmers.

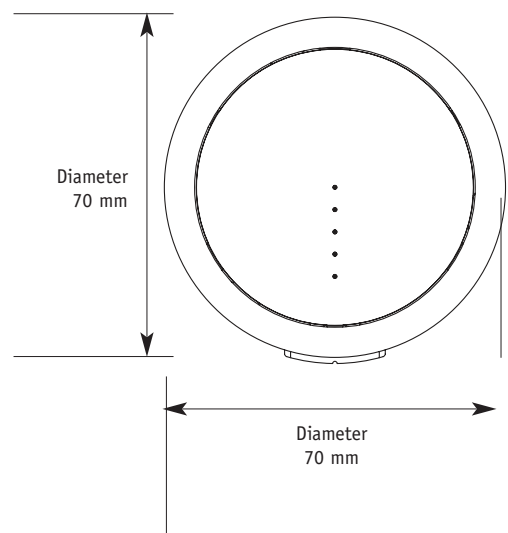


# Rania® RF Lamp Dimmers

Models	HRT-3LD-1U-: Lamp dimming control for UK plug. HRT-3LD-1E-: Lamp dimming control for European plug.
Input Voltage	220-240 V ~ 50 Hz
Regulatory Approvals	CE
Load Types	Incandescent, magnetic or electric low-voltage, tungsten halogen.
Maximum Load	300 W/VA
Minimum Load	10 W/VA
Environment	Ambient operating temperature: 0 °C to 40 °C (32 °F to 104 °F) Ambient operating humidity: 0-90% humidity, non-condensing. Indoor use only.
Addressing	Via the HomeWorks® software, using unique device serial numbers. Units must be installed prior to addressing. Counts as 1 of the 64 dimmer addresses on the RF link.
Diagnostics	LEDs provide diagnostics for troubleshooting.
ESD Protection	Meets or exceeds the IEC 61000-4-2 standard.
Surge Protection	Meets or exceeds ANSI/IEEE standard c62.41.
Fail-Safe Operation	If communication with the processor is interrupted, all <i>Rania</i> RF controls will still provide local control.
Frequency	868 MHz



**Figure 1 – Installation**



**Figure 2 – Unit Dimensions**

FRONT ROOM EQUIPMENT

# Maestro® Local Lighting Controls

## **LOCAL LIGHTING CONTROLS**

*Maestro* local lighting controls function like standard dimmers and switches, but can be controlled as part of the whole-house lighting control system. Local lighting controls are useful in locations where single circuits of lighting need to be dimmed or switched. *Maestro* dimmers have advanced features such as fade on/fade off, long fade to off, and rapid full on. In addition, the local control may be programmed similar to a keypad button press with single and double tap functions, turning on or off multiple lights. HomeWorks® *Maestro* local lighting controls install in single-pole, 2-way, or 3-way applications.

## **ACCESSORY CONTROLS**

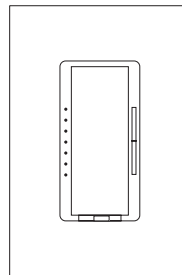
Remote dimmers (HA-RD) and remote switches (HA-RS) are used in combination with a *Maestro* local lighting control to provide 2-way and 3-way control. As many as nine (9) HA-RD or HA-RS can be used with a single *Maestro* dimmer or switch.

## **FINISHES AND COLOURS**

*Maestro* local lighting controls are available in black (BL) and white (WH) matt plastic finishes. See section 13.

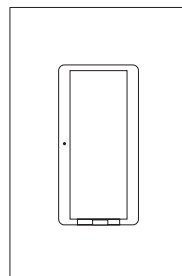
## **GANGING MAESTRO CONTROLS**

*Maestro* controls can be mounted together in a multi-gang wallbox. The load rating for each control must be derated when ganging with other controls. See page 4.14.



## **DIMMING CONTROL LOAD RATINGS**

***HWA-5E-CE and HNA-5E-CE*** dim a single incandescent or electronic low-voltage circuit up to 500 W/VA.



## **SWITCHING CONTROL LOAD RATINGS**

***HWA-2ANS-CE and HNA-2ANS-CE*** switches a single circuit of any lighting load type up to 2 A. A neutral wire connection is required.

## **INSTALLATION NOTE**

Use 89 mm (3-1/2 inch) deep wallboxes for ease of installation. Lutron® model 241218 may be used.

## **CONNECTION TO H48 DIMMER INTERFACE**

All *Maestro* local lighting controls must be connected to an H48 dimmer interface. A Dimmer Interface is available as a stand-alone component (model HWI-H48) or as an integral part of processors H4P5-**H48**-CE, H4P5-**H48**-HRL-CE, H8P5-MI-**H48**-CE and H8P5-**H48**-CE. Each *Maestro* local lighting control communicates with a dimmer interface via a one pair twisted shielded 0.5 mm<sup>2</sup> (22 AWG) cable.



# Maestro® Local Lighting Controls

<b>All HomeWorks® Maestro local lighting controls</b>	
Model	HWA-5E-CE: 500 W dimming control. HNA-5E-CE: 500 W dimming control (non-system). HWA-2ANS-CE: 2 A switching control with neutral wire. HNA-2ANS-CE: 2 A switching control with neutral wire (non-system). HA-RD: accessory control/remote dimmer. HA-RS: accessory control/remote switch.
Input voltage	220-240 V ~ 50/60 Hz
Regulatory approvals	CE, C-Tick
Environment	Ambient temperature: 0 °C to 40 °C (32 °F to 104 °F) Ambient humidity: 0-90% humidity, non-condensing. Indoor use only.
Low-voltage wire type	One pair twisted shielded 0.5-1.0 mm <sup>2</sup> (18-22 AWG) Class 2/PELV wiring.
Low-voltage wiring configuration	Daisy-chain, star, T-tap, home run. Each Maestro bus may have a maximum 150 m (500 feet) per wire run but may not exceed 305 m (1000 feet) total per bus. Maximum of eight devices per dimmer interface bus.
Addressing	Via the <i>HomeWorks</i> utility using unique device serial numbers. Units must be installed prior to addressing. Counts as 1 of 8 addresses on a Maestro bus. The device may be addressed without removing it from the wall.
ESD protection	Meets or exceeds the IEC 61000-4-2 standard.
Surge protection	Meets or exceeds ANSI/IEEE standard c62.41.
Fail-safe operation	If communication with the processor is interrupted, all Maestro controls will still provide local control.
Dimensions	See <i>figure 1, page 4.13</i> .
Mounting	Controls mount in standard US wallboxes. For easier installation, Lutron® recommends using 89mm (3-1/2 inch) deep wallboxes. <i>Lutron</i> model 241218 may be used.
Ganging	When multiple Maestro controls are located in a single wallbox, the control must be derated. See <i>page 4.14</i> . If mounting one control above another, leave at least 11.4 cm (4-1/2 inch) vertical spacing between them.
Accessory controls	Use only <i>Lutron</i> Maestro remote dimmers or switches (HA-RD or HA-RS); mechanical 2- or 3-way switches will not work. Up to 9 Maestro remote dimmers or switches may be used with one Maestro dimmer or switch.
Shipping weight	0.3 kg (0.6 pounds)

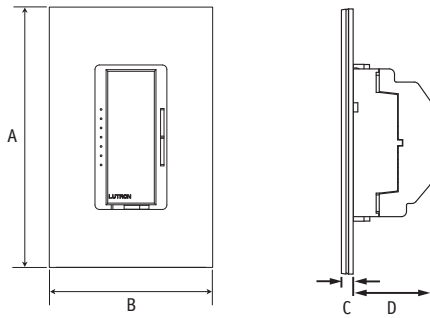
# Maestro® Local Lighting Controls

<b>HWA-5E and HNA-5E dimming control</b>	
Load types <sup>1</sup>	Incandescent, electronic low-voltage, tungsten halogen.
Maximum load	single-gang: 500 W/VA end gang: 450 W/VA middle gang: 400 W/VA Note: Mixed incandescent and electronic low-voltage loads reduces load capacity an additional 100 watts.
Minimum load	50 W/VA
Line-voltage wiring	See figures 5 and 7, pages 4.14 and 4.5. Standard single-pole, 2-way, and 3-way wiring.
<b>HWA-2ANS-CE and HNA-2ANS-CE • 2A switching control with neutral wire</b>	
Load types <sup>1</sup>	Incandescent, magnetic low-voltage <sup>2</sup> , electronic low-voltage, fluorescent with magnetic ballasts.
Maximum load	2 A
Minimum load	10 W/VA
Line-voltage wiring	See figures 6 and 8, page 4.15. Single-pole, 2-way, and 3-way wiring. A neutral wire connection is required.
<b>HA-RD • 2- or 3-way Remote Dimmer</b>	
For use with	HWA-5E-CE, HNA-5E-CE
Maximum load	See local lighting control.
Minimum load	See local lighting control.
Line-voltage wiring	See figure 7, page 4.15. Standard single-pole, 2-way, and 3-way wiring.
<b>HA-RS • 2- or 3-way Remote Switch</b>	
For use with	HWA-2ANS-CE, HNA-2ANS-CE
Maximum load	See local lighting control.
Minimum load	See local lighting control.
Line-voltage wiring	See figure 8, page 4.15. Standard single-pole, 2-way, and 3-way wiring.

(1) To reduce the risk of overheating and possibly damaging other equipment, do not install HWA-5E-CE or HNA-5E-CE to control receptacles, motor-operated appliances, fluorescent lighting, or magnetic low-voltage transformer loads. Do not install HWA-2ANS-CE or HNA-2ANS-CE to control receptacles or motor-operated appliances.

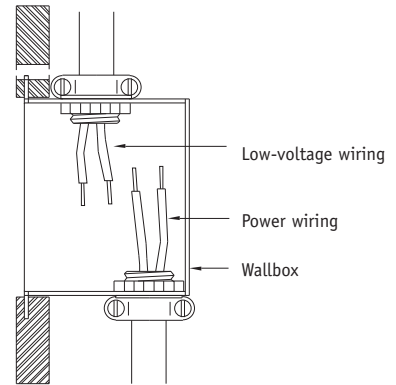
(2) Because low-voltage transformers vary widely in efficiency, the input VA of each transformer should be measured directly. If this is not possible, use the maximum lamp wattage figures, which have a built-in safety margin.

# Maestro® Local Lighting Controls

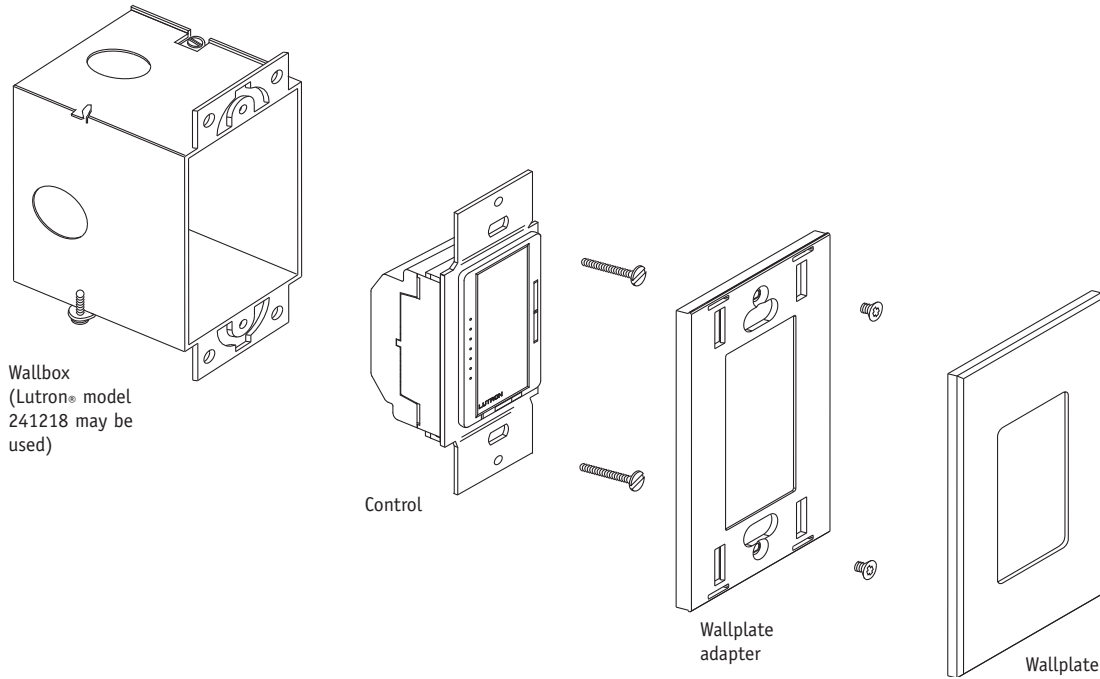


	<i>mm</i>	<i>inches</i>
A	119	4-11/16
B	75	2-15/16
C	7.6	5/16
D	34.8	1-3/8

**Figure 1 – dimensions**



**Figure 2 – wire installation**



**Figure 3 – mounting and parts identification**

FRONT ROOM EQUIPMENT

# Maestro® Local Lighting Controls

Control	Minimum load	Maximum load		
	all cases	single-gang	end gang	middle gang
HWA-5E-CE	50 W/VA	500 W/VA	450 W/VA	400 W/VA
HNA-5E-CE	50 W/VA	500 W/VA	450 W/VA	400 W/VA
HWA-2ANS-CE	10 W/VA	2A	2A	2A
HNA-2ANS-CE	10 W/VA	2A	2A </td <td>2A</td>	2A
HA-RD	n/a	n/a	n/a	n/a
HA-RS	n/a	n/a	n/a	n/a

Table 1 – minimum and maximum load ratings

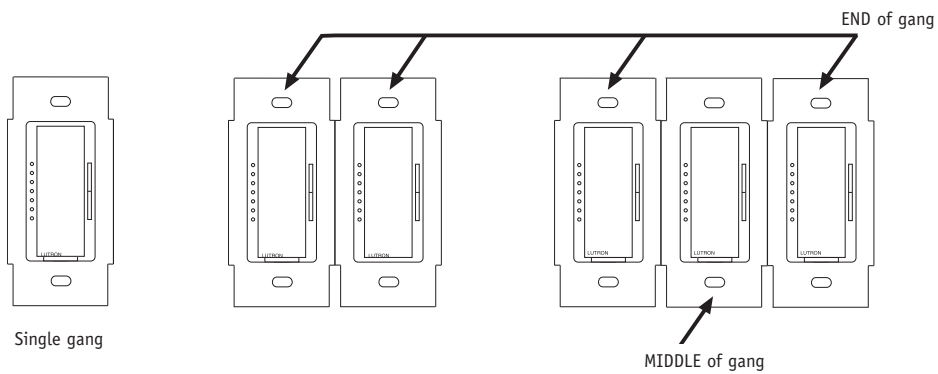


Figure 4 – ganging configuration and derating information

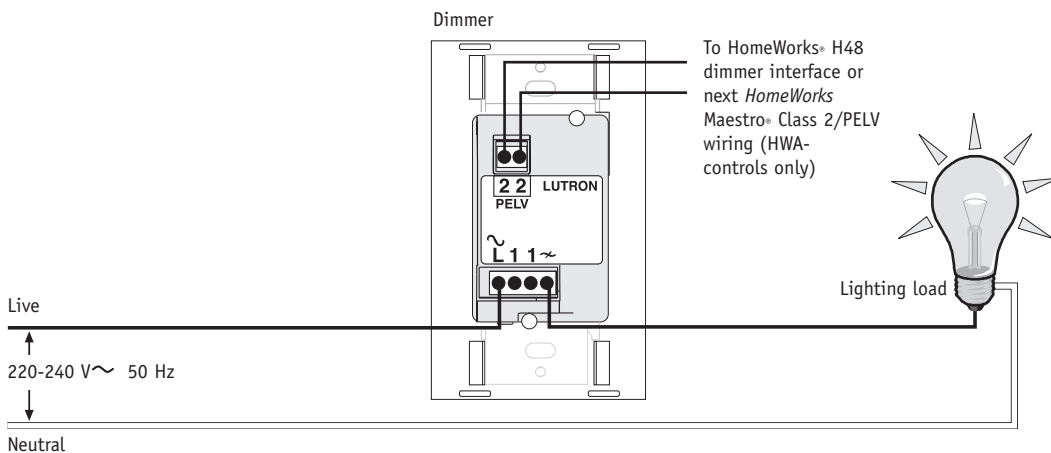


Figure 5 – HWA-5E-CE and HNA-5E-CE single-location wiring diagram

# Maestro® Local Lighting Controls

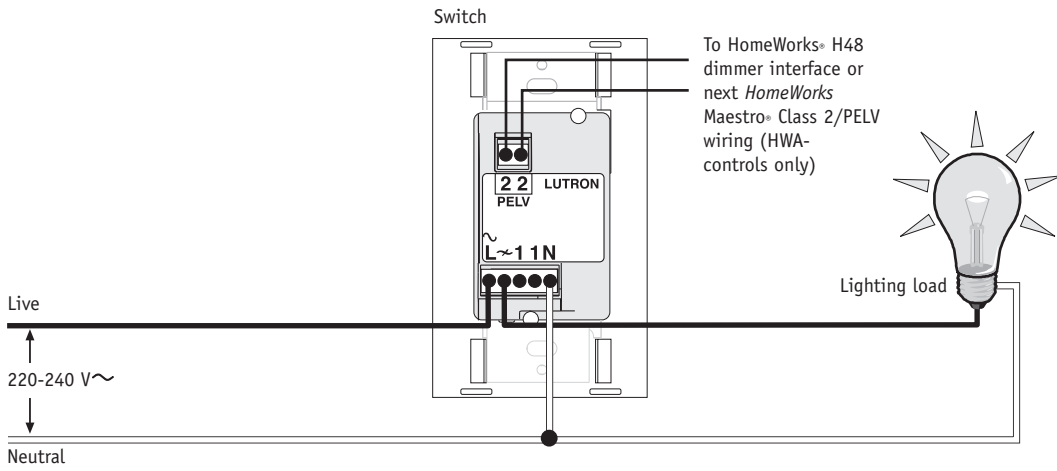


Figure 6 – HWA-2ANS-CE and HNA-2ANS-CE single-location with neutral wiring diagram

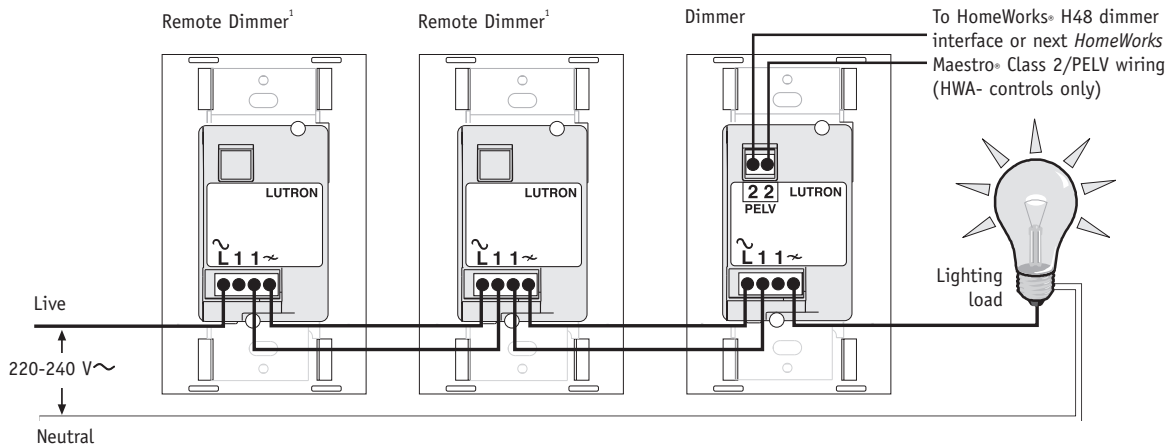


Figure 7 – HWA-5E-CE and HNA-5E-CE multi-location wiring diagram

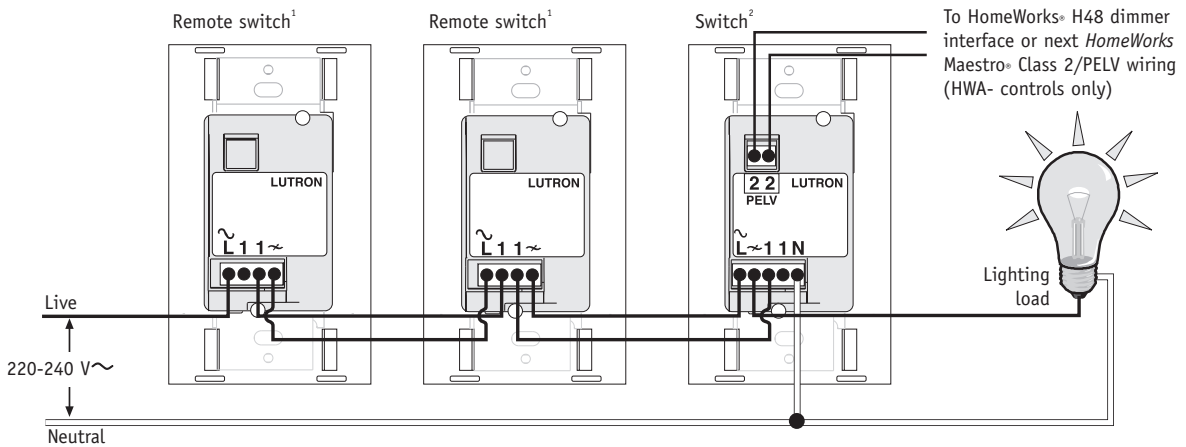


Figure 8 – HWA-2ANS-CE and HNA-2ANS-CE multi-location with neutral wiring diagram

<sup>1</sup> Up to nine *Maestro* remote dimmers or switches may be connected to the *Maestro* dimmer or switch. Total distance between all devices should not exceed 50 m (165 feet).

<sup>2</sup> Switches must be connected on the lighting load side of a multi-location installation.

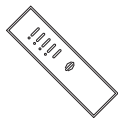
# GRAFIK Eye® Preset Local Lighting Controls

GRAFIK Eye preset local lighting controls allow you to easily create and recall multiple lighting scenes in a room. Up to 16 preset scenes can be stored in each GRAFIK Eye, making them ideal for home cinemas, living rooms, and dining rooms. GRAFIK Eye preset scenes can be easily adjusted at any time. GRAFIK Eye controls are available to dim or switch two, three, four, or six zones of lighting.

## **CONNECTION TO PROCESSOR**

Each HomeWorks® processor has three configurable links each capable of controlling up to eight GRAFIK Eye control units or WPMs. This connection requires two pair [one pair 1.0 mm<sup>2</sup> (18 AWG), one pair 0.5 to 1.0 mm<sup>2</sup> (18-22 AWG) twisted shielded] Class 2/PELV wire. Lutron® wire model GRX-CBL-346S-500 may be used. The maximum cable length is 610 m (2,000 feet), and this link must be wired in a daisy-chain configuration.

## **ACCESSORY CONTROLS**

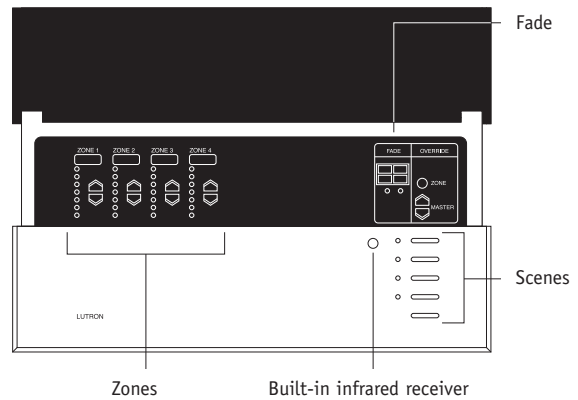


**Handheld Infrared  
Remote Control Transmitters  
GRX-IT, GRX-8IT (white only)**

Controls four or eight scenes plus master raise/lower and off.

## **FINISHES AND COLOURS**

GRAFIK Eye preset local lighting controls are available in matt plastic finishes and metallic finishes. See section 13.



**GRAFIK Eye preset lighting control  
(GRX-3504-CE shown)**

## **GRAFIK EYE CONTROL UNIT INSTALLATION NOTES**

Use 89 mm (3-1/2 inch) deep wallboxes for ease of installation of GRAFIK Eye control units. (Lutron model 241400)

# GRAFIK Eye® Preset Local Lighting Controls

<b>Control Units</b>	
Model	GRX-3502-CE, GRX-3503-CE, GRX-3504-CE, GRX-3506-CE: allows scene and zone control from HomeWorks®.  GRX-3102-CE, GRX-3103-CE, GRX-3104-CE, GRX-3106-CE: allows scene control only from HomeWorks.
Input voltage	220-240 V ~ 50/60 Hz
Regulatory approvals	CE, C-Tick
Load types	Incandescent, magnetic low-voltage, electronic low-voltage (requires Lutron® low-voltage transformers), fluorescent non-dim, neon/cold cathode. The outputs are also compatible with Lutron Power Boosters and interfaces on <i>in section 6</i>
Maximum load (CE)	See table on <i>page 4.18</i> .
Minimum load	25 W/VA per zone.
Environment	Ambient temperature: 0 °C to 40 °C (32 °F to 104 °F) Ambient humidity: 0-90% humidity, non-condensing. Indoor use only.
Cooling method	Passive cooling.
Line-voltage connections	See <i>figures 3 and 4, page 4.20</i> .
Low-voltage wire type	Two pair [one pair 1.0 mm <sup>2</sup> (18 AWG), one pair 0.5 to 1.0 mm <sup>2</sup> (18-22 AWG) twisted shielded] Class 2/PELV wire. Lutron wire model GRX-CBL-346S-500 may be used.
Low-voltage wiring configuration	Maximum of 610 m (2,000 feet) total. Must be wired in a daisy-chain configuration. See <i>figures 5 and 6, page 4.21</i> .
Low-voltage connections	One 4-pin removable terminal block. Each of the four terminals will accept up to two 1.0 mm <sup>2</sup> (18 AWG) wires. Do not connect terminal 2 on processor communication link connector or between GRX units.
Addressing	Via 7-segment display. Use 1 of 8 addresses on a GRAFIK Eye link.
ESD protection	Meets or exceeds the IEC 61000-4-2 standard.
Surge protection	Meets or exceeds ANSI/IEEE standard c62.41.
Air gap	Provided when all circuits are off.
Power-failure memory	Non-volatile RAM.
Fail-safe operation	If communication with the processor is interrupted, all GRAFIK Eye controls will still provide local control.
Dimensions	See <i>figure 1, page 4.19</i> .
Mounting (CE)	All CE-compliant units mount in 4-gang US wallbox 7.0 cm (2-3/4 inches) deep minimum, 8.9 cm (3-1/5 inch) deep recommended for ease of wiring. Lutron model 241400 may be used.
Shipping weight	0.9 kg (2.0 pounds)

# GRAFIK Eye® Preset Local Lighting Controls

<b>GRAFIK Eye control units capacities</b>							
GRAFIK Eye model	Voltage	Maximum watts per zone		Maximum watts per control unit		Wallbox size (gangs)	
		CE	non-CE	CE	non-CE	CE	non-CE
2-zone	220-240 V	800	1200	1600	1600	4	2
3-zone	220-240 V	800	1200	2300	2400	4	3
4-zone	220-240 V	800	1200	2300	3000	4	4
6-zone	220-240 V	800	1200	2300	3000	4	4

**Note:** The sum of the wattages of the individual zones cannot exceed the total capacity of the control unit. For wattages exceeding those listed above, a Power Booster or interface is required.



# GRAFIK Eye® Preset Local Lighting Controls

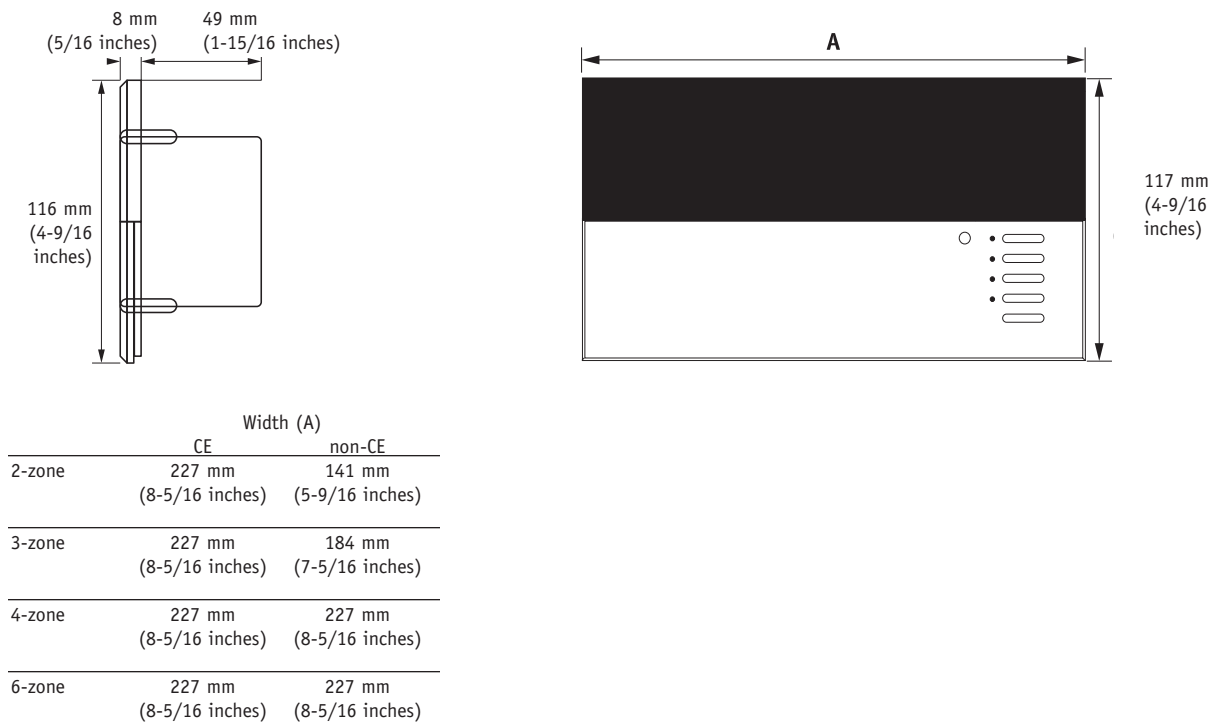


Figure 1 – dimensions

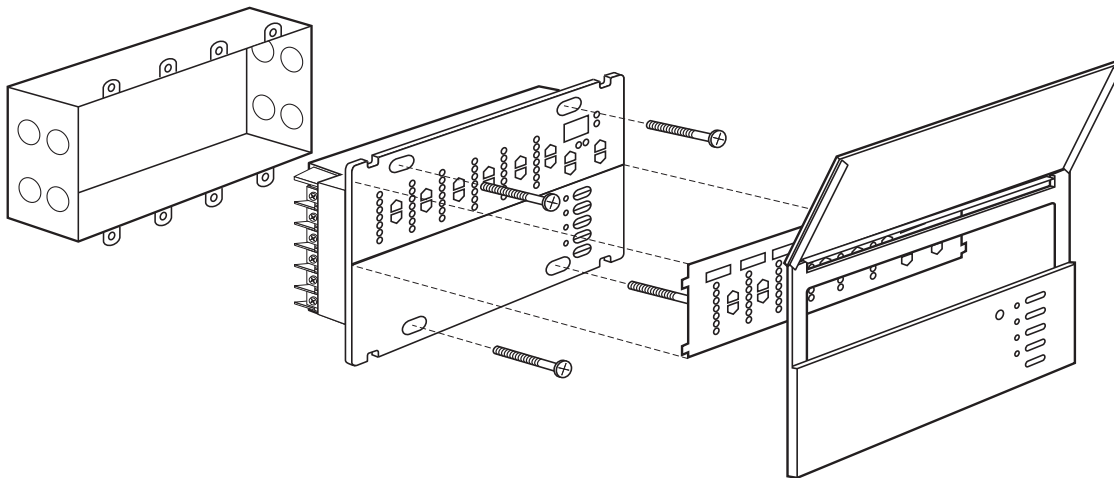


Figure 2 – mounting

FRONT ROOM EQUIPMENT

# GRAFIK Eye® Preset Local Lighting Controls

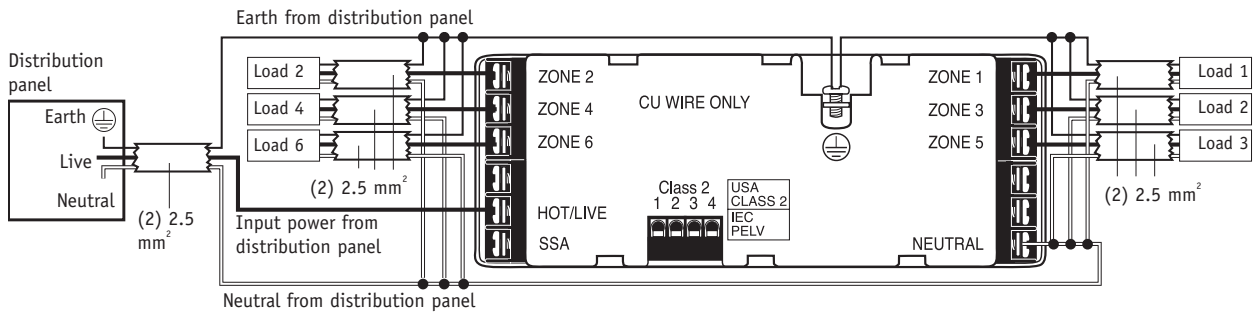


Figure 3 – GRX-3106-AU and GRX-3506-AU wiring diagram (Non-CE)

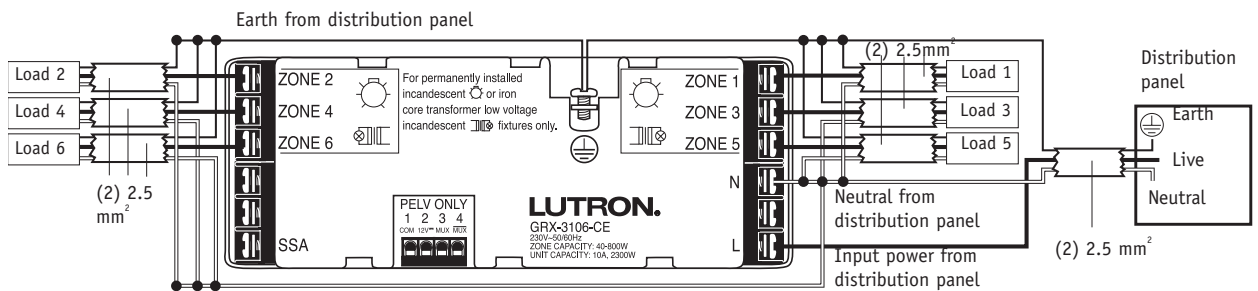


Figure 4 – GRX-CE models wiring diagram (-CE)

FRONT ROOM EQUIPMENT

# GRAFIK Eye® Preset Local Lighting Controls

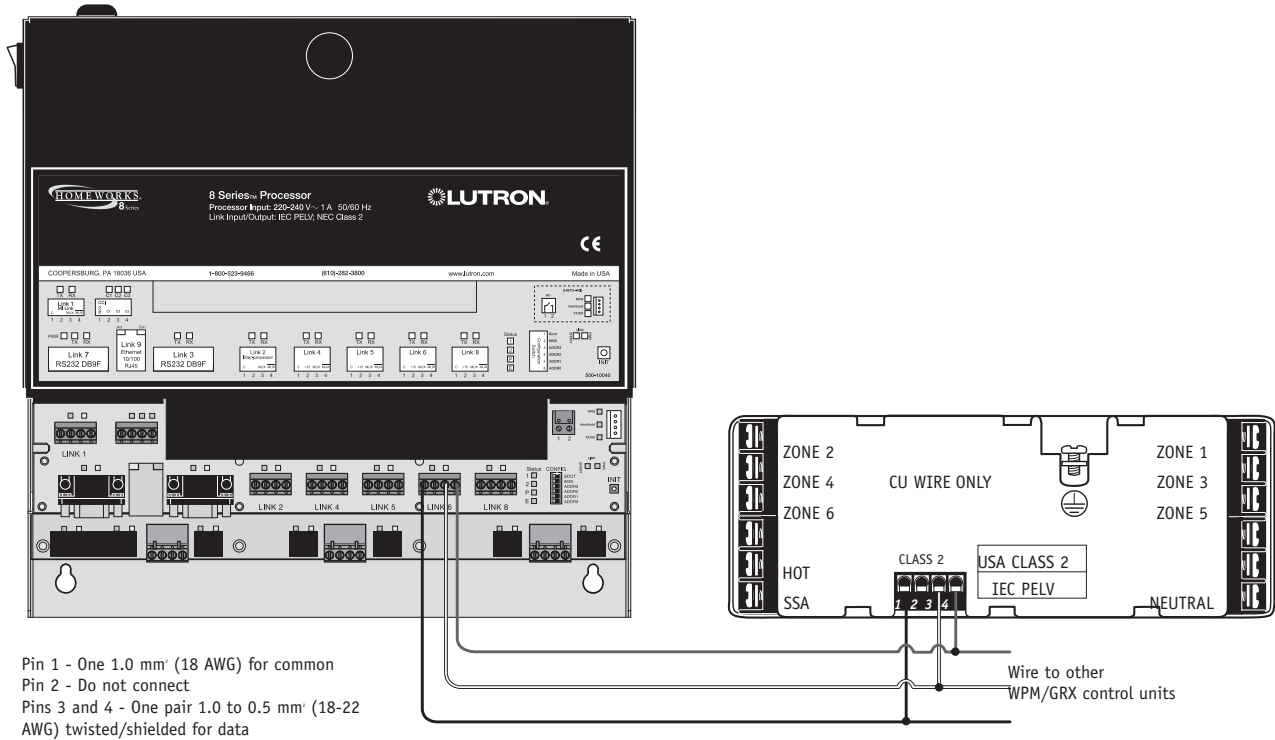


Figure 5 – connection to processor

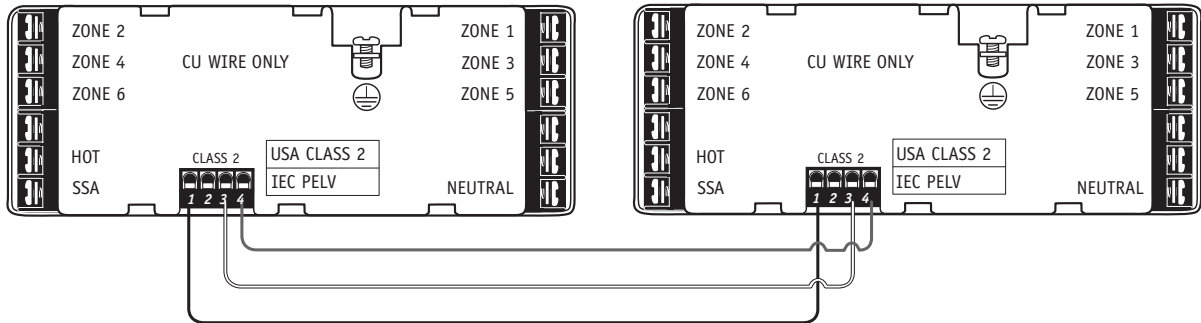


Figure 6 – connection to other GRAFIK Eye control units

**Notes:**

Connection between #2 terminals is not made between GRAFIK Eye control units and the HomeWorks® processor.

Connection between #2 terminals is not made between two GRAFIK Eye control units.

A maximum of 8 GRX and WPM may be wired to one processor link.

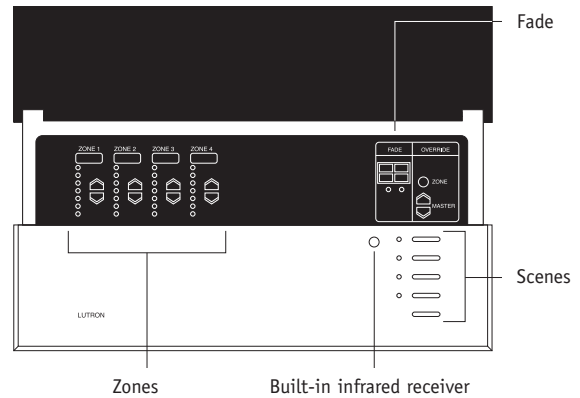
FRONT ROOM EQUIPMENT

# GRAFIK Integrale® Preset Local Lighting Control

*GRAFIK Integrale* has the same features and functions of the *GRAFIK Eye*® 3000 series control units. In addition, *GRAFIK Integrale* can directly control electronic low-voltage lighting, 0-10 V ballasts, DSI ballasts and DALI ballasts (intensity broadcast only) without requiring additional interfaces.

*GRAFIK Integrale* is only available in a 4 lighting zone configuration. The total unit capacity is 2300 W/VA. The capacity of a single zone is 800 W/VA and a maximum of 20 fluorescent ballasts.

Connection to processor, accessory controls, and finishes and colours are the same as *GRAFIK Eye* models. See section 13.



***GRAFIK Integrale GXI-3104-T-CE or GXI-3504-T-CE lighting control***

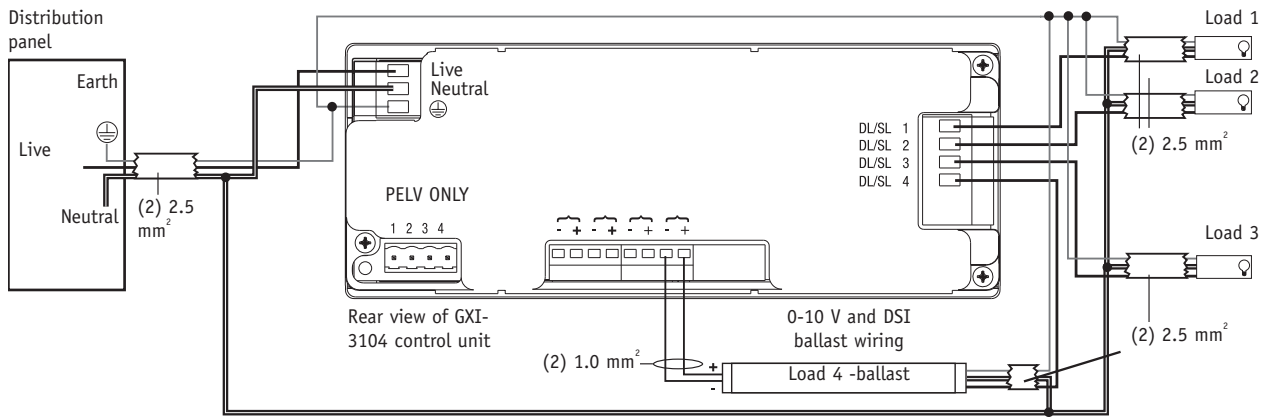
## **GRAFIK INTEGRALE CONTROL UNIT INSTALLATION NOTES**

Use 89 mm (3-1/2 inch) deep wallboxes for ease of installation of *GRAFIK Eye* control units. (Lutron® model 241400)

# GRAFIK Integrale® Preset Local Lighting Control

<b>Control unit</b>	
Model	GXI-3504-T-CE: allows scene and zone control from HomeWorks®. GXI-3104-T-CE: allows scene control only from HomeWorks.
Input voltage	220-240 V ~ 50/60 Hz
Regulatory approvals	CE, C-Tick, VDE
Load types	Incandescent, magnetic low-voltage, neon/cold cathode, fluorescent, electronic low-voltage. Ballast control outputs are compatible with 0-10V, DSI and DALI ballasts.
Maximum load (CE)	2300 W/VA total, 800 W/VA per zone.
Minimum load	25 W/VA per zone.
Environment	Ambient temperature: 0 °C to 40 °C (32 °F to 104 °F) Ambient humidity: 0-90% humidity, non-condensing. Indoor use only.
Cooling method	Passive cooling.
Line-voltage connections	See figure 1, page 4.26.
Low-voltage wire type	Two pair [one pair 1.0 mm² (18 AWG), one pair 0.5 to 1.0 mm² (18-22 AWG) twisted shielded] Class 2/PELV wire. Lutron® wire model GRX-CBL-346S-500 may be used.
Low-voltage wiring configuration	Maximum of 610 m (2,000 feet) total. Must be wired in a daisy-chain configuration. See figures 5 and 6, page 4.21.
Low-voltage connections	One 4-pin removable terminal block. Each of the four terminals will accept up to two 1.0 mm² (18 AWG) wires. Do not connect terminal 2 on processor communication link connector or between GXI units.
Addressing	Via 7-segment display. Use 1 of 8 addresses on a GRAFIK Eye® link.
ESD protection	Meets or exceeds the IEC 61000-4-2 standard.
Surge protection	Meets or exceeds ANSI/IEEE standard c62.41.
Air gap	Provided when all circuits are off.
Power-failure memory	Non-volatile RAM.
Fail-safe operation	If communication with the processor is interrupted, all GRAFIK Integrale controls will still provide local control.
Dimensions	See figure 1, page 4.19.
Mounting (CE)	All CE-compliant units mount in 4-gang US wallbox 7.0 cm (2-3/4 inch) deep minimum, 8.9 cm (3-1/5 inch) deep recommended for ease of wiring. Lutron model 241400 may be used.
Shipping weight	0.9 kg (2.0 pounds)

# GRAFIK Integrale® Preset Local Lighting Control



**Figure 1 – mains voltage wiring**

## **LOW-VOLTAGE WIRING**

GRAFIK Integrale uses the same low-voltage wiring as the GRAFIK Eye® control units. Refer to the diagrams on page 4.21.

---

# Keypads and Contact Closure Interfaces

# Keypads

HomeWorks® keypads are available in many styles, colours, and finishes. Keypads provide clients with a simple and elegant way to operate lights, shades, motorised screens, and many other devices. Keypads have LEDs that provide status indication. Lutron® provides custom engraving to clearly identify each button's function.

Each button on every keypad model can be programmed to control any lighting load or device on the *HomeWorks* system.

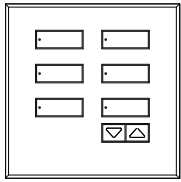
Each *HomeWorks* processor has three or four configurable links, each capable of controlling up to 32 keypads and Contact Closure Interfaces.

## **CONNECTION TO PROCESSOR**

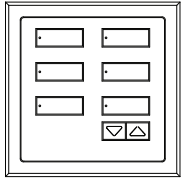
A total of 32 keypads can be connected to a single link on a *HomeWorks* processor using two pair [one pair 1.0 mm<sup>2</sup> (18 AWG), one pair 1.0 to 0.5 mm<sup>2</sup> (18-22 AWG) twisted shielded] Class 2/PELV cable. Only up to 10 keypads or interfaces can be connected on a single wire run. The maximum total cable length of any single wire run is 305 m (1,000 feet). Keypads may be wired in a daisy-chain, home run, star, or T-tap configuration. The maximum total cable length for a keypad link is 1220 m (4,000 feet).



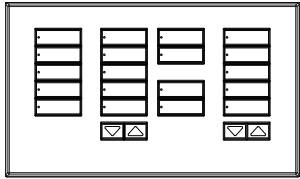
# Keypad Styles



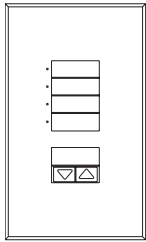
**International seeTouch® - without insert**



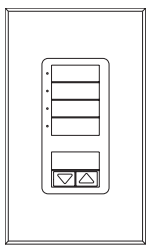
**International seeTouch - with insert**



**Dual international seeTouch**



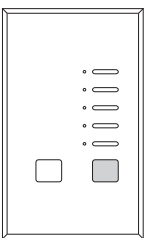
**seeTouch - without insert**



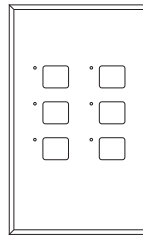
**seeTouch - with insert**



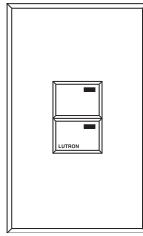
**European-style**



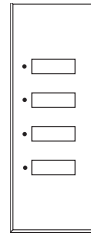
**Slim button**



**Large button**



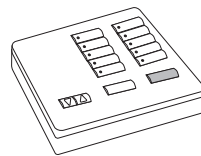
**2-button**



**Signature Series™**



**Architrave™**



**Tabletop**  
(see chapter 10)



**Web**

# International seeTouch® Keypads

## ***International seeTouch KEYPADS***

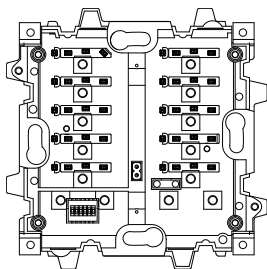
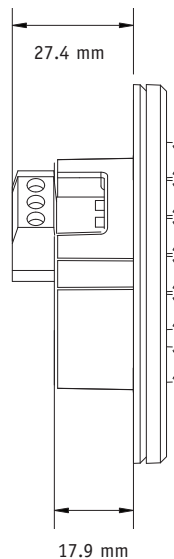
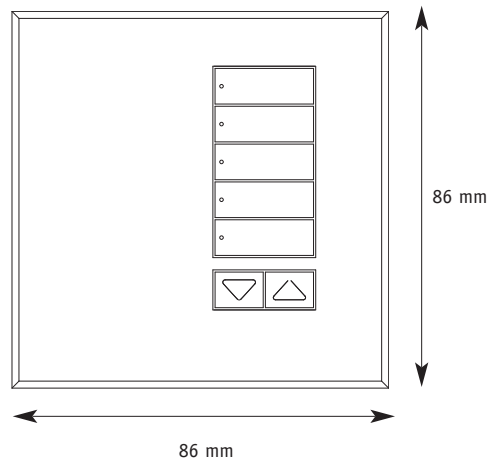
The *seeTouch* keypads feature large, easy-to-use buttons, plus unique backlit engraving that makes the keypads readable any time of the day or night. *seeTouch* buttons are rounded, allowing engraving to be displayed at an upward angle which increases readability. *seeTouch* keypads are available with two to ten buttons, allowing you to customise the number of functions.

The flexible design allows the number of buttons and the configuration of the buttons to be changed, even after the keypad is installed.

International *seeTouch* keypads have two contact closure inputs on the back of the unit which provide independent functions from the front buttons. Other options include configurations with infrared receiver and raise/lower buttons.

## ***ORDERING METHOD***

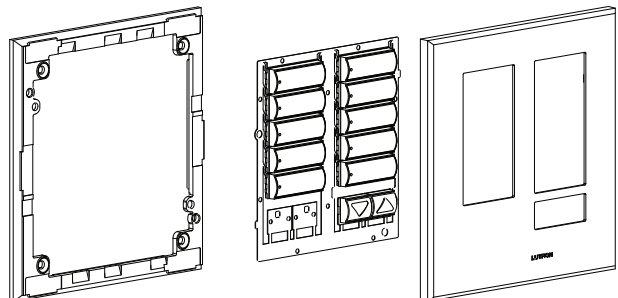
- a) Order base unit without buttons or faceplate.  
Non-IR: HWIS-NB-NONE  
IR: HWIS-NBIR-NONE
- b) Order engraved button/faceplate kit.  
HWIS-XX-Y-ZZ  
where XX is the configuration type  
Y is "F" for Frameless or "I" for with "Insert"  
ZZ is the finish colour code  
*See pages 5.5 and 5.6 for standard model numbers.*
- c) Button/faceplate kit will include a certificate for a set of engraved replacement buttons to be redeemed in the future.



HWIS-NB-NONE  
Base unit without IR receiver

HWIS-NBIR-NONE  
Base unit with IR receiver

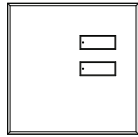
Button/Faceplate Kit



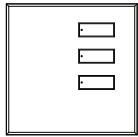
# International seeTouch® Keypads

## BUTTON/FACEPLATE KITS

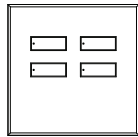
### *Without Insert*



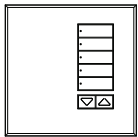
HWIS-2B-F-XX  
2-button



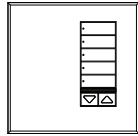
HWIS-3B-F-XX  
3-button



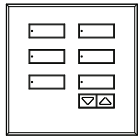
HWIS-4B-F-XX  
4-button



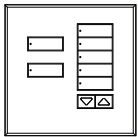
HWIS-5BRL-F-XX  
5-button - with raise/lowers



HWIS-5BIR-F-XX  
5-button - with raise/lowers  
and IR receiver



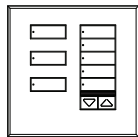
HWIS-6BRL-F-XX  
6-button - with raise/lowers



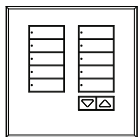
HWIS-7BRL-F-XX  
7-button - with raise/lowers



HWIS-8BRL-F-XX  
8-button - with raise/lowers

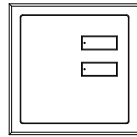


HWIS-8BIR-F-XX  
8-button - with raise/lowers  
and IR receiver

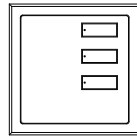


HWIS-10BRL-F-XX  
10-button - with raise/lowers

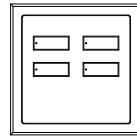
### *With Insert*



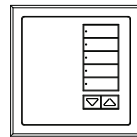
HWIS-2B-I-XX  
2-button



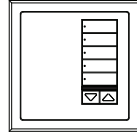
HWIS-3B-I-XX  
3-button



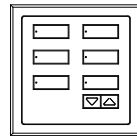
HWIS-4B-I-XX  
4-button



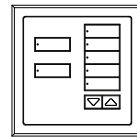
HWIS-5BRL-I-XX  
5-button - with raise/lowers



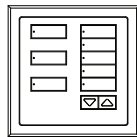
HWIS-5BIR-I-XX  
5-button - with raise/lowers  
and IR receiver



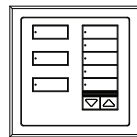
HWIS-6BRL-I-XX  
6-button - with raise/lowers



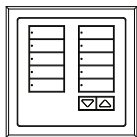
HWIS-7BRL-I-XX  
7-button - with raise/lowers



HWIS-8BRL-I-XX  
8-button - with raise/lowers



HWIS-8BIR-I-XX  
8-button - with raise/lowers  
and IR receiver



HWIS-10BRL-I-XX  
10-button - with raise/lowers

XX= Colour Code

# International seeTouch® Keypads – Wiring and Mounting

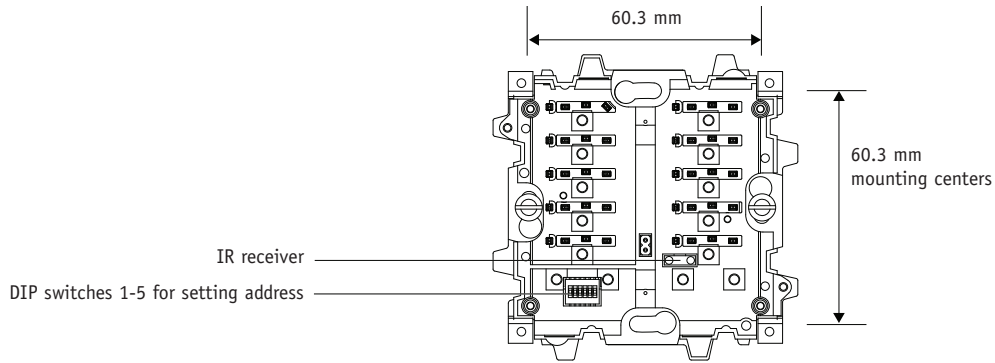
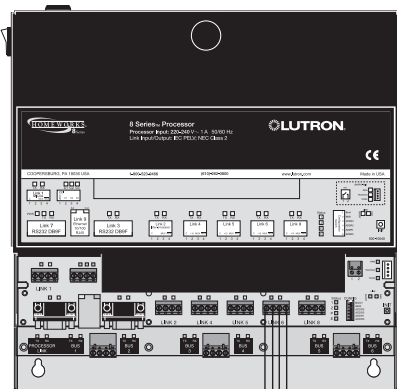


Figure 1 – base unit front view (without faceplate)

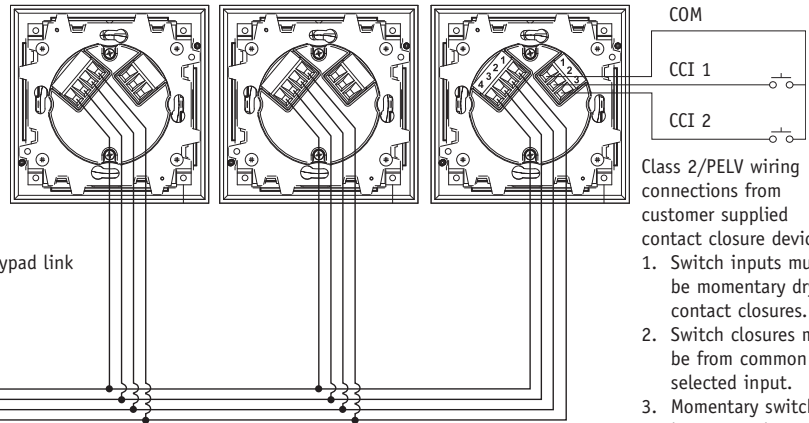


HomeWorks® processor

- 10 keypads max per home run
- 32 keypads max per keypad link
- 1 220 m max wire length per processor link

Note: each keypad draws 15 LED count from the processor.

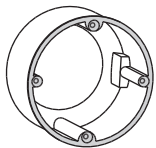
Keypad rear view



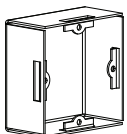
- Class 2/PELV wiring connections from customer supplied contact closure devices.
1. Switch inputs must be momentary dry contact closures.
  2. Switch closures must be from common to selected input.
  3. Momentary switch inputs require a minimum closure time of 40 msec.

Pins 1 and 2 – 1 pair 1.0 mm<sup>2</sup> (18 AWG) for power  
 Pins 3 and 4 – 1 pair 0.5 to 1.0 mm<sup>2</sup> (22-18 AWG) twisted/shielded for data  
*Lutron* wire, model GRX-CBL-3465-500, may be used.

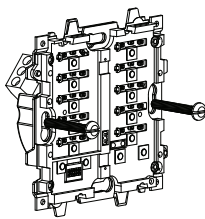
Figure 2 – wiring diagram



Round backbox (40 mm deep)  
 Lutron® P/N EBB-15-RD for 15



Square backbox (35 mm deep)  
 Lutron P/N EBB-15-SQ for 15  
 P/N 241-683 for 1



base unit

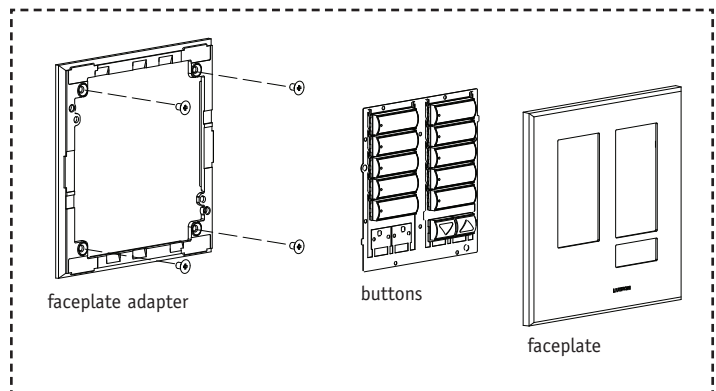


Figure 3 – mounting diagram

# Dual International seeTouch® Keypads

## ***DUAL INTERNATIONAL seeTouch KEYPADS***

The dual international *seeTouch* keypad makes a dual-gang arrangement easy. In addition to its backlit buttons, the dual international *seeTouch* keypad provides the flexibility of adding the functionality of two keypads under one flush frameless wall plate.

Featuring a single button kit, the dual international *seeTouch* keypad allows the configuration of the buttons to be change, even after the keypad is installed. The dual keypad takes up two separate addresses on the HomeWorks® system and also takes up two physical nodes on a *HomeWorks* keypad wiring run.

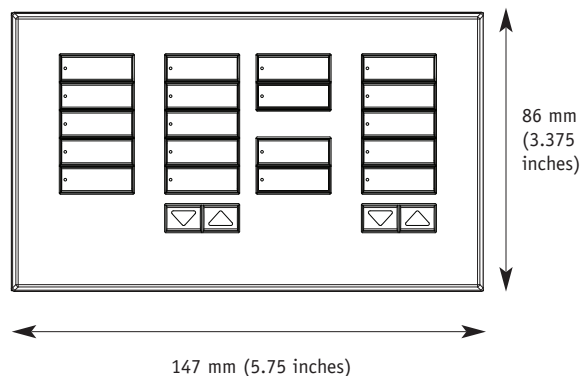
## ***ORDERING METHOD***

The dual international *seeTouch* keypad is ordered in two parts.

- a) Order base unit without buttons or faceplate.  
HWIS-2-NBIR-NONE
- b) Order engraved button/faceplate kit. Each button/faceplate kit will be a custom part because of the amount of possible configurations.  
HWIS-XX-YY-2G-ZZ-CPN4855

-XX is the number of buttons for the left gang  
-YY is the number of buttons for the right gang  
-ZZ is the finish. These keypads are only available in standard metal finishes or custom finishes

**Note:** the model number does not detail the configuration of the keypad. You must complete a configuration and engraving form and submit it with your order. These forms can be found on the *HomeWorks* Resource site.



***Dual International seeTouch keypad***

# Dual International seeTouch® Keypads – Wiring and Mounting

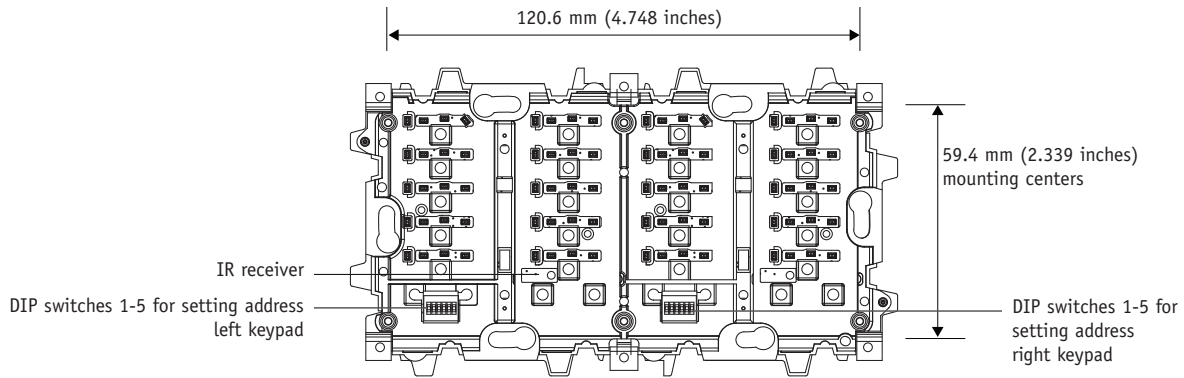
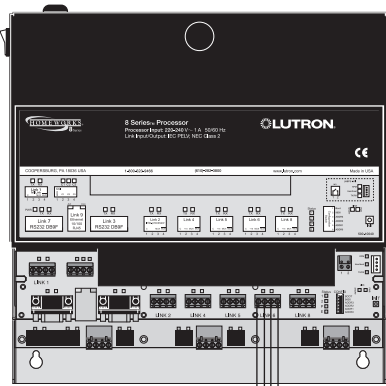


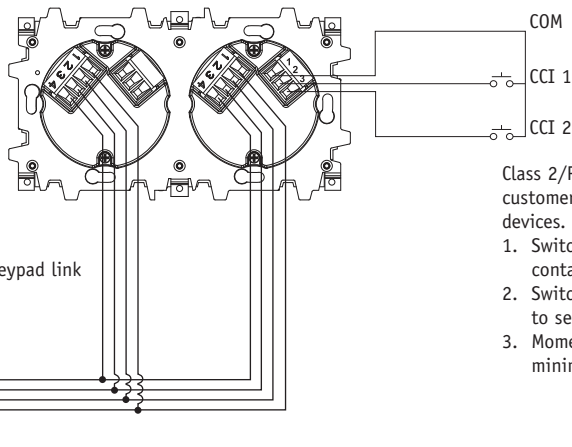
Figure 1 – base unit front view (without faceplate)



HomeWorks® processor  
 10 keypads max per home run  
 32 keypads max per keypad link  
 1 220 m max wire length per processor link

Note: Dual international seeTouch keypad is a combination of two individual keypads in one. Each keypad draws 15 LED count from the processor for a total of 30 LEDs

Keypad rear view

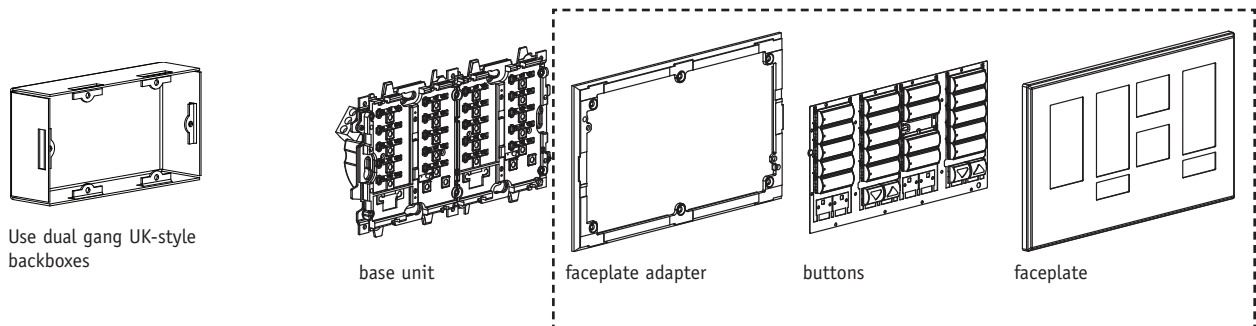


Class 2/PELV wiring connections from customer supplied contact closure devices.

1. Switch inputs must be momentary dry contact closures.
2. Switch closures must be from common to selected input.
3. Momentary switch inputs require a minimum closure time of 40 msec.

Pins 1 and 2 – 1 pair 1.0 mm<sup>2</sup> (18 AWG) for power  
 Pins 3 and 4 – 1 pair 0.5 to 1.0 mm<sup>2</sup> (22-18 AWG) twisted/shielded for data  
 Lutron wire, model GRX-CBL-3465-500, may be used.

Figure 2 – wiring diagram



Use dual gang UK-style backboxes

base unit

faceplate adapter

buttons

faceplate

Figure 3 – mounting diagram

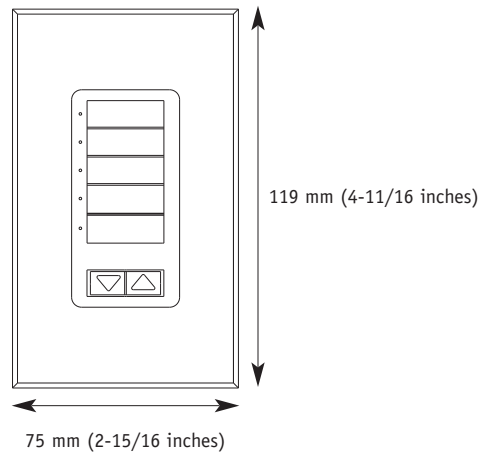
# seeTouch® Keypads

## **seeTouch KEYPADS**

The *seeTouch* keypads feature large, easy-to-use buttons, plus a unique backlit engraving option that makes the keypads readable any time of the day or night. *seeTouch* buttons are rounded, allowing engraving to be displayed at an upward angle and increasing readability. *seeTouch* keypads are available with one to seven buttons, allowing you to customize the number of functions.

The flexible design allows the number of buttons and the configuration of the buttons to be changed even after the keypad is installed.

*seeTouch* keypads have two contact closure inputs on the back of the unit which provide independent functions from the front buttons. Other options include configurations with infrared receiver and raise/lower buttons.



## **FINISHES AND COLOURS**

Available in matt plastic finishes and metallic finishes. See section 13.

## **ORDERING METHODS**

### **a) Engraving will be decided after installation**

- 1) Order keypad with button/faceplate.  
ST-model-colour
- 2) After engraving is determined, order engraved button/faceplate kit.  
SK-model-colour-E

### **b) Engraving will be decided before installation**

- 1) Order keypad without buttons or faceplate.  
Non-IR: ST-NB-NONE  
IR: ST-NBIR-NONE
- 2) Order engraved button/faceplate kit.  
SK-model-colour-E

# seeTouch® Keypads

## *seeTouch - WITHOUT INSERT*

### **1-button**



Keypad: ST-1B-NI-XX  
 Button/Faceplate: SK-1B-NI-XX-E  
 Description: 1-button - without insert

### **2-button**



Keypad: ST-2B-NI-XX  
 Button/Faceplate: SK-2B-NI-XX-E  
 Description: 2-button - without insert

### **3-button**



Keypad: ST-3B-NI-XX  
 Button/Faceplate: SK-3B-NI-XX-E  
 Description: 3-button - without insert



Keypad: ST-3BRL-NI-XX  
 Button/Faceplate: SK-3BRL-NI-XX-E  
 Description: 3-button with raise/lower - without insert

### **4-button**



Keypad: ST-4B-NI-XX  
 Button/Faceplate: SK-4B-NI-XX-E  
 Description: 4-button - without insert



Keypad: ST-4FS-NI-XX  
 Button/Faceplate: SK-4FS-NI-XX-E  
 Description: 4-button favorite scenes - without insert



Keypad: ST-4S-NI-XX  
 Button/Faceplate: SK-4S-NI-XX-E  
 Description: 4-scene - without insert



Keypad: ST-4SIR-NI-XX  
 Button/Faceplate: SK-4SIR-NI-XX-E  
 Description: 4-scene with IR receiver - without insert

### **5-button**



Keypad: ST-5B-NI-XX  
 Button/Faceplate: SK-5B-NI-XX-E  
 Description: 5-button - without insert



Keypad: ST-5FS-NI-XX  
 Button/Faceplate: SK-5FS-NI-XX-E  
 Description: 5-button favorite scene - without insert



Keypad: ST-5BRL-NI-XX  
 Button/Faceplate: SK-5BRL-NI-XX-E  
 Description: 5-button with raise/lower - without insert

### **6-button**



Keypad: ST-6B-NI-XX  
 Button/Faceplate: SK-6B-NI-XX-E  
 Description: 6-button - without insert



Keypad: ST-6BRL-NI-XX  
 Button/Faceplate: SK-6BRL-NI-XX-E  
 Description: 6-button with raise/lower - without insert

### **7-button**



Keypad: ST-7B-NI-XX  
 Button/Faceplate: SK-7B-NI-XX-E  
 Description: 7-button - without insert

### **Wallbox**



Model: 241218  
 Description: US style metal wallbox



# seeTouch® Keypads

## seeTouch - WITH INSERT

### **1-button**



Keypad: ST-1B-I-XX  
 Button/Faceplate: SK-1B-I-XX-E  
 Description: 1-button - with insert

### **2-button**



Keypad: ST-2B-I-XX  
 Button/Faceplate: SK-2B-I-XX-E  
 Description: 2-button - with insert

### **3-button**



Keypad: ST-3B-I-XX  
 Button/Faceplate: SK-3B-I-XX-E  
 Description: 3-button - with insert



Keypad: ST-3BRL-I-XX  
 Button/Faceplate: SK-3BRL-I-XX-E  
 Description: 3-button with raise/lower - with insert

### **4-button**



Keypad: ST-4B-I-XX  
 Button/Faceplate: SK-4B-I-XX-E  
 Description: 4-button - with insert



Keypad: ST-4FS-I-XX  
 Button/Faceplate: SK-4FS-I-XX-E  
 Description: 4-button favorite scenes - with insert



Keypad: ST-4S-I-XX  
 Button/Faceplate: SK-4S-I-XX-E  
 Description: 4-scene - insert



Keypad: ST-4SIR-I-XX  
 Button/Faceplate: SK-4SIR-I-XX-E  
 Description: 4-scene with IR receiver - with insert

### **5-Button**



Keypad: ST-5B-I-XX  
 Button/Faceplate: SK-5B-I-XX-E  
 Description: 5-button - with insert



Keypad: ST-5FS-I-XX  
 Button/Faceplate: SK-5FS-I-XX-E  
 Description: 5-button favorite scene - with insert



Keypad: ST-5BRL-I-XX  
 Button/Faceplate: SK-5BRL-I-XX-E  
 Description: 5-button with raise/lower - with insert

### **6-button**



Keypad: ST-6B-I-XX  
 Button/Faceplate: SK-6B-I-XX-E  
 Description: 6-button - with insert



Keypad: ST-6BRL-I-XX  
 Button/Faceplate: SK-6BRL-I-XX-E  
 Description: 6-button with raise/lower - with insert

### **7-button**



Keypad: ST-7B-I-XX  
 Button/Faceplate: SK-7B-I-XX-E  
 Description: 7-button - with insert

## seeTouch - BASE UNIT WITHOUT BUTTONS

### **No-button**



Keypad: ST-NB-NONE  
 Description: Without buttons

Keypad: ST-NBIR-NONE  
 Description: Without buttons with IR receiver

### **Wallbox**



Model: 241218  
 Description: US style metal wallbox

XX= Colour Code

# seeTouch® Keypads – Bang & Olufsen Compatible

## BANG & OLUFSEN® COMPATIBLE KEYPADS

Bang & Olufsen compatible keypads have the same design and functionality as the normal European-style keypads. In addition, the Bang & Olufsen compatible keypads with an IR receiver allow the user to control the HomeWorks® system from a Bang & Olufsen Beo4® remote control.

### FINISHES AND COLOURS

Available in black (BL) or white (WH) matt plastic finish or satin nickel (SN) metal finish. Engraving is also available.

### NOTES

- 1) *seeTouch* Bang & Olufsen compatible keypads do NOT include any contact closure inputs
- 2) Unengraved units have colour bars in the middle of the buttons
- 3) Engraved units have colour bars at the bottom of the buttons

## BANG & OLUFSEN COMPATIBLE KEYPADS

### **IR remote**



Keypad: STBO-4SIRI-XX-  
Faceplate only: SKBO-4SIRI-XX-E  
Description: 4-scene with off, raise/lower, IR reciver, with insert



Keypad: STBO-4SIRN-XX-  
Faceplate only: SKBO-4SIRN-XX-E  
Description: 4-scene with off, raise/lower, IR reciver, no insert

### **Non IR**



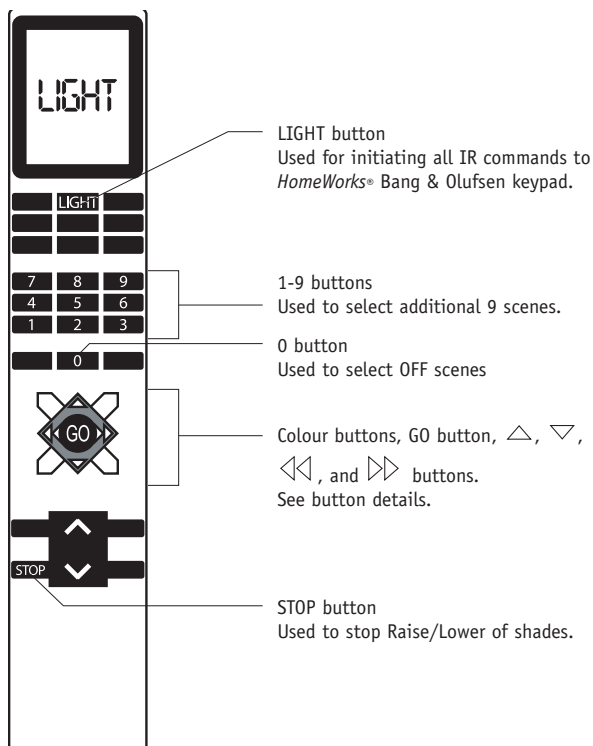
Keypad: STBO-4SI-XX-  
Faceplate only: SKBO-4SI-XX-E  
Description: 4-scene with off, raise/lower, with insert



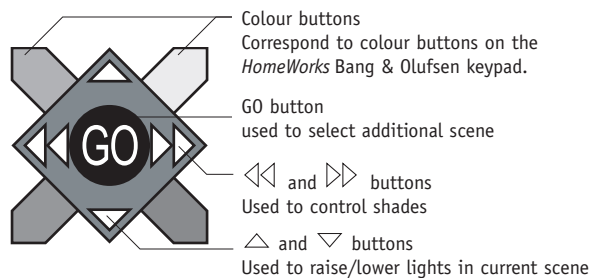
Keypad: STBO-4SN-XX-  
Faceplate only: SKBO-4SN-XX-E  
Description: 4-scene with off, raise/lower, no insert



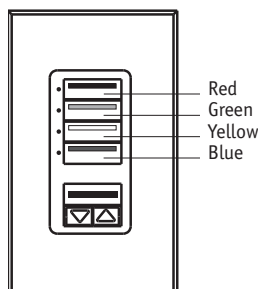
## BANG & OLUFSEN® COMPATIBLE KEYPADS



**Figure 1 – Beo4® IR remote control button function**

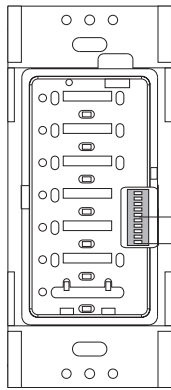


**Figure 2 – Beo4 button detail**



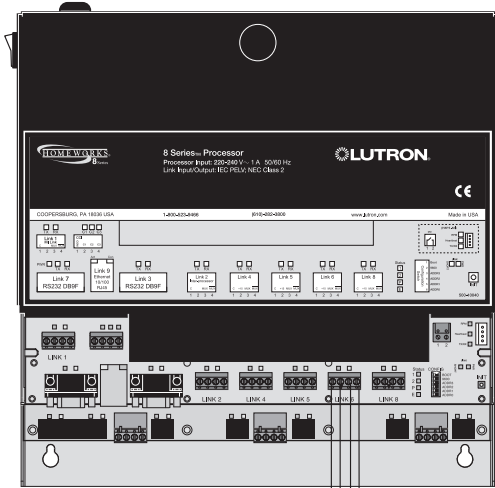
**Figure 3 – keypad button detail (STBO-4SIRI shown)**

# seeTouch® Keypads – Wiring and Mounting



Set DIP switches 1-5 to give the keypad a unique HomeWorks® system address from 1 to 32. See page 5.29.

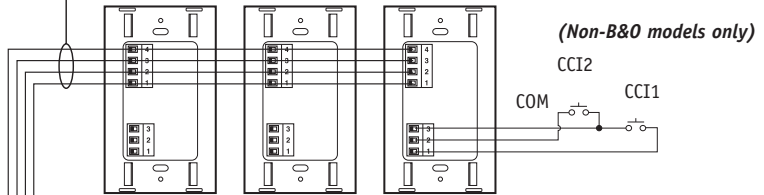
**Figure 4 – keypad front view (wallplate, wallplate adapter, and button kit removed) DIP Switches**



HomeWorks processor (8 series shown)

10 keypads max per home run  
32 keypads max per keypad link  
1 220 m max wire length per processor link

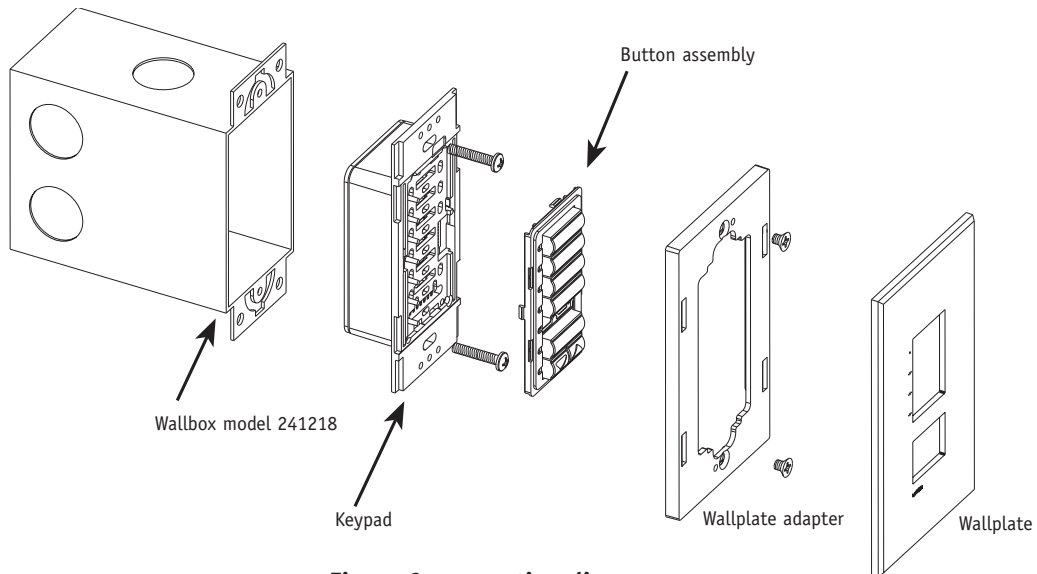
Pins 1 and 2 – 1 pair 1.0 mm<sup>2</sup> (18 AWG) for power.  
Pins 3 and 4 – 1 pair 0.5 to 1.0 mm<sup>2</sup> (22-18 AWG) twisted/shielded for data.  
Lutron® wire, model GRX-CBL-346S-500, may be used.



Class 2/PELV wiring connections from customer supplies contact closure devices.

1. Switch inputs must be momentary dry contact closures.
2. Switch closures must be from common to selected input.
3. Momentary switch inputs require a minimum closure time of 40 msec.

**Figure 5 – wiring diagram**



**Figure 6 – mounting diagram**

# European-style Keypads

## **EUROPEAN-STYLE KEYPADS**

European-style keypads provide the ability to control and monitor lighting, audio, video, and other home systems throughout the home. The design of this keypad features large, rounded buttons, and large LEDs to clearly show lighting status. European-style keypads are available with master raise/lower and/or infrared receiver. Buttons are rounded, allowing engraving to be displayed at an upward angle and increasing readability.

## **FINISHES AND COLOURS**

Available in black (BL) and white (WH) matt plastic finishes. Faceplates are also available in metal finishes. See section 13.

## **ORDERING METHOD**

- 1) Order keypad with buttons/faceplate.  
HWI-model-colour
- 2) After engraving is determined, order engraved faceplate with same number of buttons as control.  
EFP-model-colour

**These keypads will be obsoleted in 2009 (except B&O version). Do not use these keypads for new projects. Contact Lutron Customer Service for availability.**

## **EUROPEAN-STYLE KEYPADS**

### ***2-button***



Keypad: HWI-2SE-XX  
Faceplate only: EFP-2B-SL-XX  
Description: 2-scene

### ***4-button***



Keypad: HWI-4SE-M-XX  
Faceplate only: EFP-4SE-M-XX  
Description: 4-scene with off and raise/lower



Keypad: HWI-4SE-IR-XX  
Faceplate only: EFP-4SE-IR-XX  
Description: 4-scene with off, raise/lower and IR receiver

### ***8-button***



Keypad: HWI-8SE-M-XX  
Faceplate only: EFP-8SE-M-XX  
Description: 8-scene with off and raise/lower



Keypad: HWI-8SE-IR-XX  
Faceplate only: EFP-8SE-IR-XX  
Description: 8-scene with off, raise/lower and IR receiver

### ***Wallboxes***

Model: EBB-15-RD  
Description: Round plastic wallbox for European-style keypads (15 plastic wallboxes)

Model: EBB-15-SQ  
Description: Square metal wallbox for European-style keypads (15 metal wallboxes)

# European-style Keypads

## ***BANG & OLUFSEN® COMPATIBLE KEYPADS***

Bang & Olufsen compatible keypads have the same design and functionality as the normal European-style keypads. In addition, the Bang & Olufsen compatible keypads with an IR receiver allow the user to control the HomeWorks® system from a Bang & Olufsen Beo4® remote control.

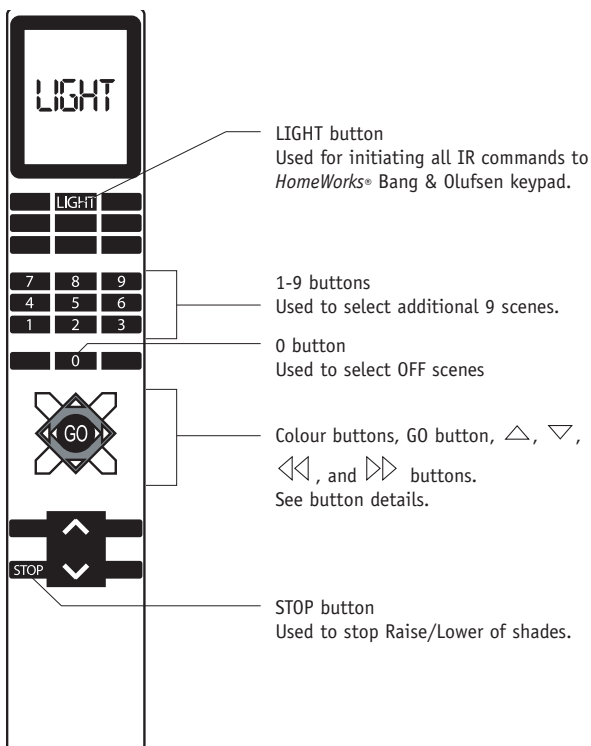
## ***FINISHES AND COLOURS***

Available in black (BL) or white (WH) matt plastic finish or satin nickel (SN) metal finish. Engraving is also available.

## ***ORDERING METHOD***

- 1) Order keypad with buttons/faceplate.  
HWI-model-colour
- 2) After engraving is determined, order engraved faceplate with same number of buttons as control.  
EFP-model-colour

## ***BANG & OLUFSEN® COMPATIBLE KEYPADS***



**Figure 1 – Beo4® IR remote control button function (HWBO-4SE-IR and HWBO-8SE-IR only)**

## ***BANG & OLUFSEN COMPATIBLE KEYPADS***

### ***4-button***



Keypad: HWBO-4SE-M-XX  
Faceplate only: EFP-4SE-M-XX  
Description: 4-scene with off and raise/lower

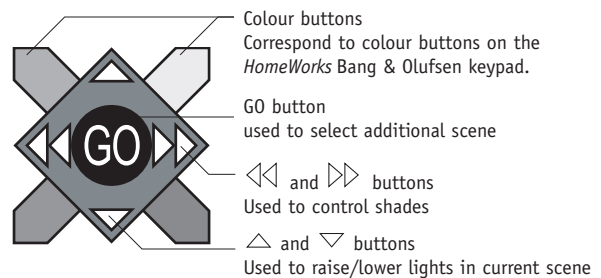


Keypad: HWBO-4SE-IR-XX  
Faceplate only: EFP-4SE-IR-XX  
Description: 4-scene with off, raise/lower and IR receiver

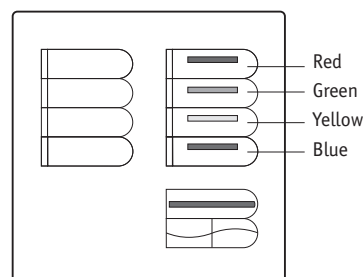
### ***8-button***



Keypad: HWBO-8SE-IR-XX  
Faceplate only: EFP-8SE-IR-XX  
Description: 8-scene with off, raise/lower and IR receiver

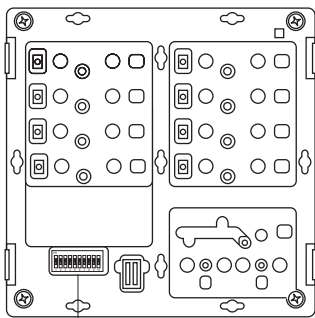


**Figure 2 – Beo4 button detail**



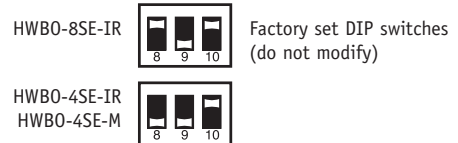
**Figure 3 – keypad button detail (HWBO-8SE-IR shown)**

# European-style Keypads – Wiring and Mounting

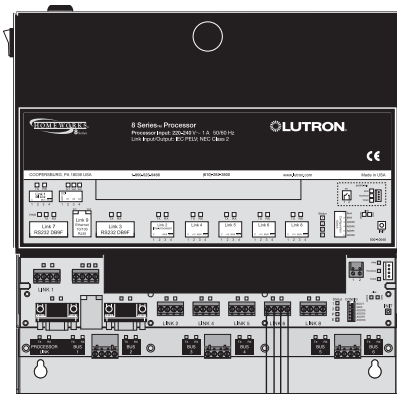


DIP switches 1-5 for setting address. DIP switches 6-10 do not affect keypad address.

**Figure 1 – keypad front view (faceplate removed)**



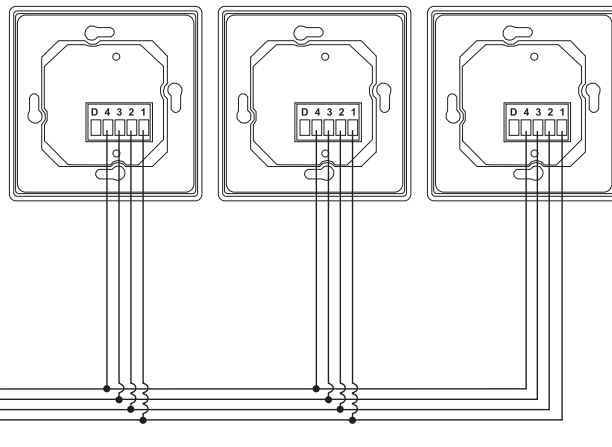
**Figure 2 – factory set DIP switches**



HomeWorks® processor

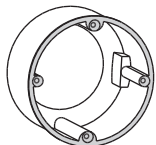
- 10 keypads max per home run
- 32 keypads max per keypad link
- 1 220 m max wire length per processor link

Keypad rear view

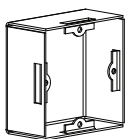


Pins 1 and 2 – 1 pair 1.0 mm<sup>2</sup> (18 AWG) for power  
Pins 3 and 4 – 1 pair 0.5 to 1.0 mm<sup>2</sup> (22-18 AWG) twisted/shielded for data  
Lutron® wire, model GRX-CBL-3465-500, may be used.

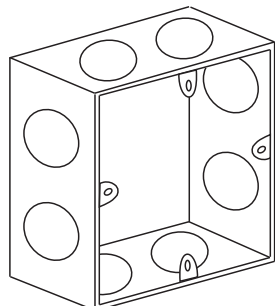
**Figure 3 – wiring diagram**



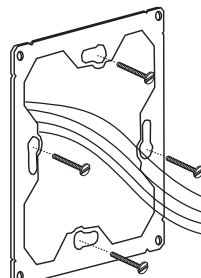
Round backbox (40 mm deep)



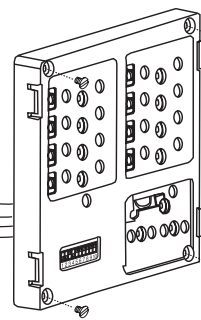
U.K. backbox (35 mm deep)



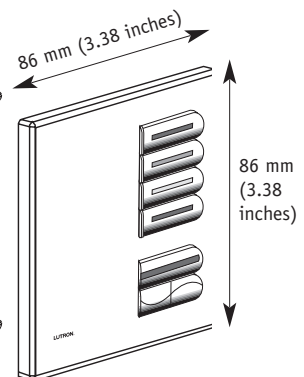
Lutron wallbox model 241-683



Adapter plate



Keypad



Faceplate

**Figure 4 – mounting diagram**

# Keypads – Slim Button

## **SLIM BUTTON WITHOUT INSERT KEYPADS**

Slim button keypads provide the largest number of buttons in the smallest size. Slim Button keypads feature multiple button columns and two large buttons.

Button labels can be engraved below each button.

## **FINISHES AND COLOURS**

Available in matt plastic finishes and metallic finishes. See section 13.

## **SLIM BUTTON WITHOUT INSERT KEYPADS**

### **5-button**



Keypad: HWI-KP5-XX  
Faceplate only: HW-B1-NFB-XX  
Description: 5-button with master on/off

### **10-button**



Keypad: HWI-KP10-XX  
Faceplate only: HW-B2-NFB-XX  
Description: 10-button with master on/off

### **15-button<sup>1</sup>**



Keypad: HWI-KP15-XX  
Faceplate only: HW-B3-NFB-XX  
Description: 15-button with master on/off

### **Wallbox**



Model: 241218  
Description: US style metal wallbox

<sup>1</sup> 15 button control requires 2 wallboxes model number 241218.

XX= Colour Code

# Keypads – Large Button and 2-Button

## LARGE BUTTON KEYPADS

The design of this keypad features large, easy-to-use buttons. Large button keypads feature multiple button columns which provide logical partitioning of keypad functions.

Button labels can be engraved on or below each button.

## FINISHES AND COLOURS

Available in matt plastic finishes and metallic finishes. See section 13.

## LARGE BUTTON KEYPADS

### **6-Button**



Keypad: HWI-KP-LB6-XX  
Faceplate only: HWI-B4-NFB-XX  
Description: 6-button

### **9-Button<sup>1</sup>**



Keypad: HWI-KP-LB9-XX  
Faceplate only: HWI-B5-NFB-XX  
Description: 9-button

### **Wallbox**



Model: 241218  
Description: US style metal wallbox

## 2-BUTTON KEYPAD

The design of this keypad features two large buttons. 2-button keypads are ideal for areas where simple control is required. Typical locations include hallways, bathrooms, and small rooms.

Button labels can be engraved on each button. 2-button keypads have two contact closure inputs on the back of the unit which provide independent functions from the front buttons.

## FINISHES AND COLOURS

2-button keypads include a faceplate and keypads are available in matt plastic finishes and metallic finishes. See section 13.

## 2-BUTTON KEYPAD

### **2-Button**



Keypad: HWI-2B-XX  
Faceplate only: NT-T8-NFB-XX  
Description: 2-button

### **Wallbox**



Model: 241218  
Description: US style metal wallbox

<sup>1</sup> 9 and 15 button controls require 2 wallboxes model number 241218.

XX= Colour Code



# Slim and Large Button Keypads – Wiring and Mounting

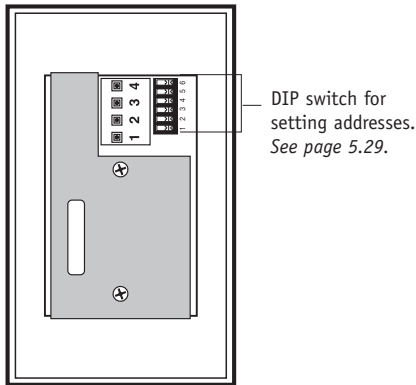


Figure 1 – keypad rear view

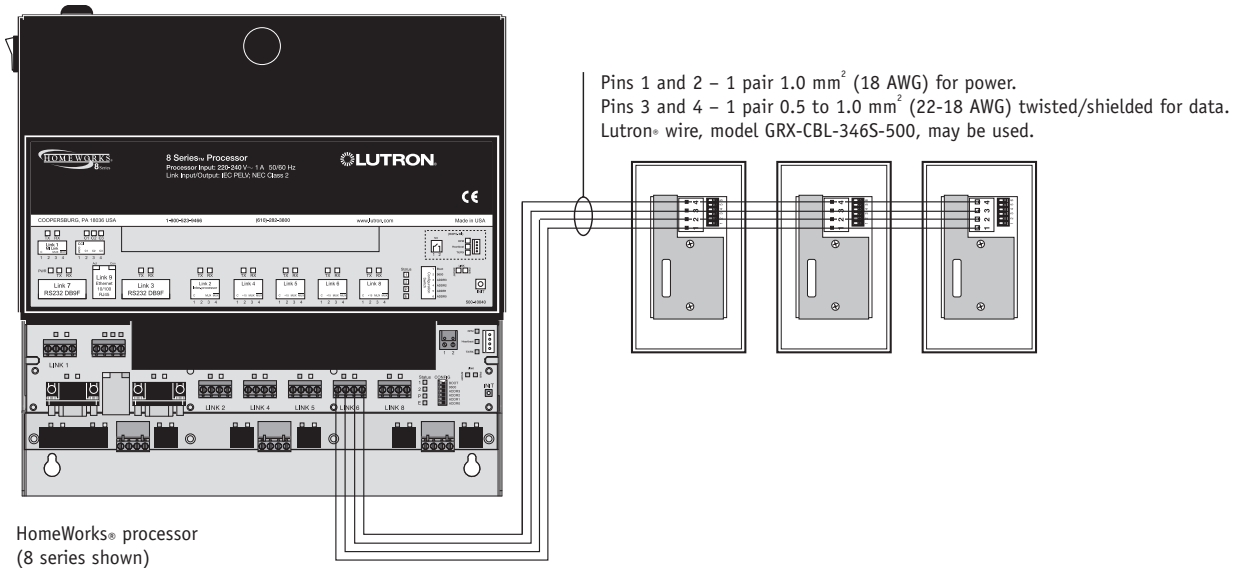


Figure 2 – wiring diagram

10 keypads max per home run  
32 keypads max per keypad link  
1 220 m max wire length per processor link

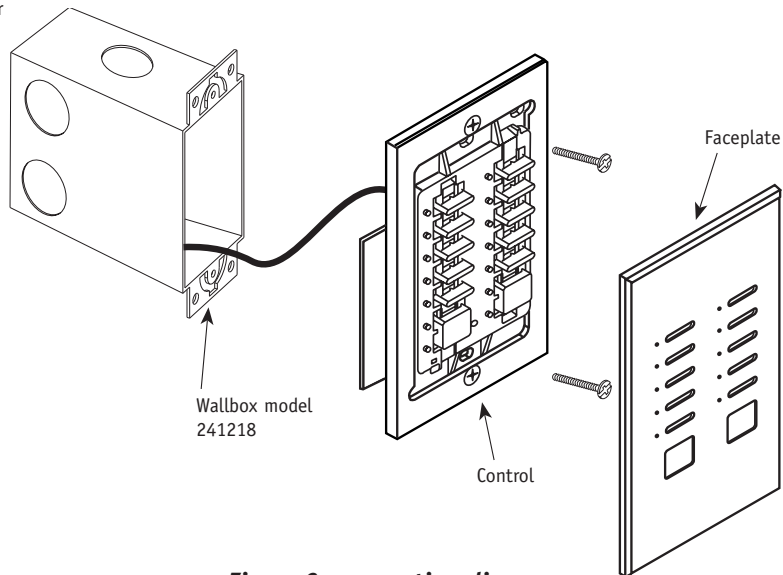


Figure 3 – mounting diagram

FRONT ROOM EQUIPMENT

# 2-Button Keypads – Wiring and Mounting

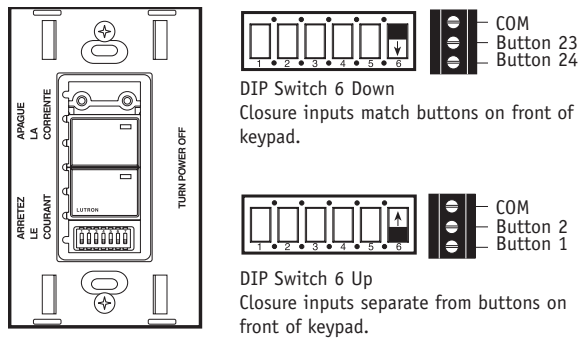
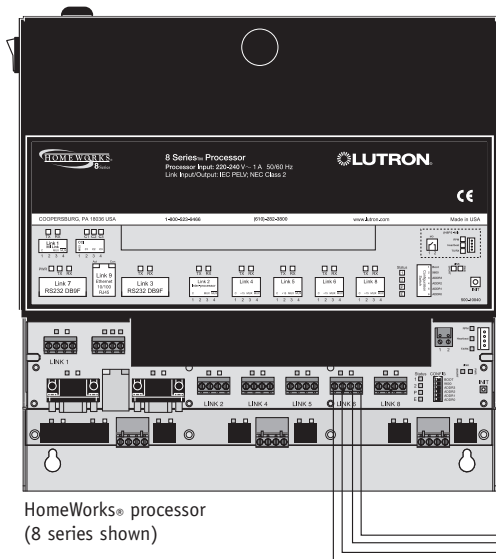


Figure 1 – button assignment for contact closure inputs



10 keypads max per home run  
32 keypads max per keypad link  
1 220 m max wire length per processor link

Figure 2 – wiring diagram

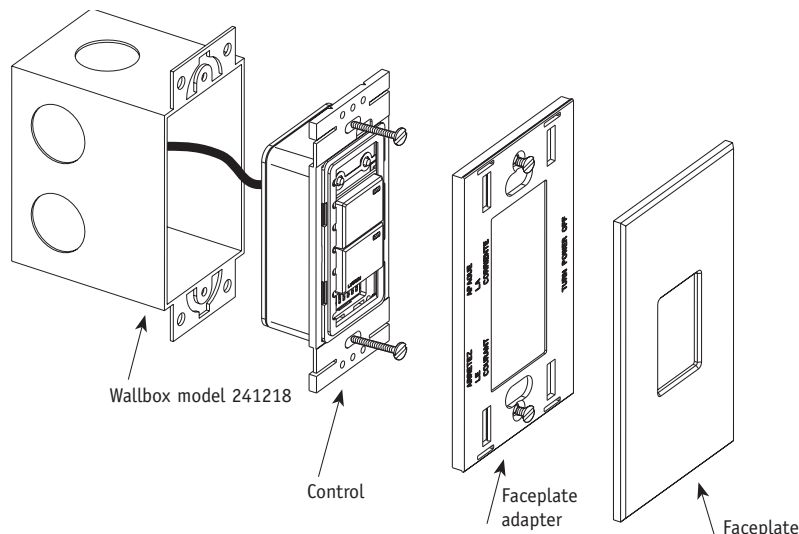


Figure 3 – mounting diagram

# Keypads – Signature Series™

## **SIGNATURE SERIES™ KEYPADS**

*Signature Series* keypads allow you to incorporate the functions of standard-size keypads into a slim control that offer a unique and elegant look. *Signature Series* keypads include 3- and 4-button configurations, with blue or green status indicators. *Signature Series* keypads feature large, easy-to-use buttons, plus a unique backlit (blue or green) engraving option that makes the keypads readable any time of the day or night. Buttons are rounded, allowing engraving to be displayed at an upward angle and increasing readability.

*Signature Series* keypads may be mounted with or without a wallbox (WBOX-SA1-Q1).

## **FINISHES AND COLOURS**

*Signature Series* keypads ship with solid metal faceplates. Metal finishes include: white (WH) (Monterey only), bright brass (BB), satin nickel (SN), bright chrome (BC), field paintable (FP), unfinished brass (UB), and 24K gold plated (AU).

## **ORDERING METHOD**

- 1) Order keypad with buttons/faceplate.  
HWS-model-colour
- 2) After engraving is determined, order engraved button kit with same number of buttons as control.  
HKS-model-colour-E

## **SIGNATURE SERIES KEYPADS**

### **3-button Monaco™ (blue status indicators)**



Keypad: HWS-3B-B-XX  
Button Kit: HKS-3B-BL-E  
Description: 3-button

### **4-button Monaco (blue status indicators)**



Keypad: HWS-4B-B-XX  
Button Kit: HKS-4B-BL-E  
Description: 4-button

### **3-button Monterey™ (green status indicators)**



Keypad: HWS-3B-G-XX  
Button Kit: For white Monterey keypads only  
HKS-3B-WH-E

Button Kit: For non-white Monterey keypads  
HKS-3B-BL-E  
Description: 3-button

### **4-button Monterey (green status indicators)**



Keypad: HWS-4B-G-XX  
Button Kit: For white Monterey keypads only  
HKS-4B-WH-E

Button Kit: For non-white Monterey keypads  
HKS-4B-BL-E  
Description: 4-button

### **Wallbox**



Model: WBOX-SA1-Q1  
Description: *Signature Series* wallbox

# Keypads – Architrave™

## ARCHITRAVE KEYPADS

Architrave keypads allow you to incorporate the functions of standard-size keypads into a slim control that fits flush into a door trim, door jamb, or custom cabinetry. Architrave keypads can also be used at standard switch locations throughout your home to add a unique and elegant look. Architrave keypads can be engraved, below each button, with names of your choosing. Architrave keypads may be mounted with or without a wallbox.

## FINISHES AND COLOURS

Available in metallic finishes. See section 13.

## ORDERING METHOD

- 1) Order keypad with buttons/faceplate.  
HWI-model-colour
- 2) After engraving is determined, order engraved faceplate with same number of buttons as control.  
AR-M4-model-colour  
(Excludes HWI-LB5-DC1)

## ARCHITRAVE KEYPADS

### **5-button**



Keypad: HWI-KP5-DN-XX  
Faceplate only: AR-M4-DN-XX  
Description: Door narrow 5-button with master on/off



Keypad: HWI-KP5-DW-XX  
Faceplate only: AR-M4-DW-XX  
Description: Door wide 5-button with master on/off



Keypad: HWI-LB5-DC1-XX  
Faceplate only: Custom  
Description: 5 large buttons with raise/lower

### **Wallboxes**



241-399  
Wallbox for HWI-KP5-DW  
Wallbox for HWI-KP5-DN



241-663  
Wallbox for HWI-LB5-DC1

# Signature Series™ and Architrave™ – Wiring

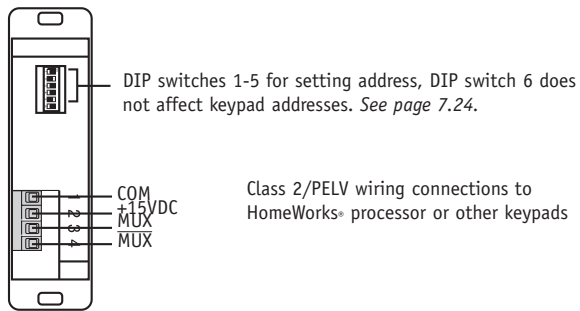


Figure 1 – keypad rear view

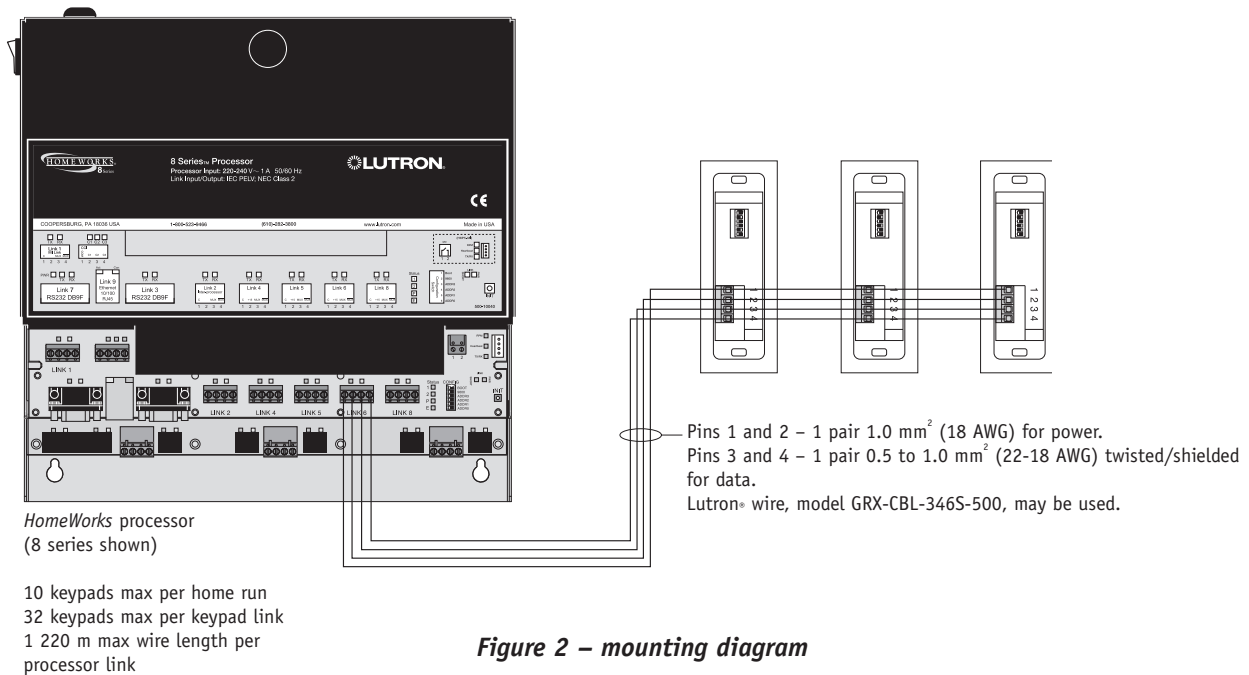


Figure 2 – mounting diagram

# Signature Series™ and Architrave™ – Mounting

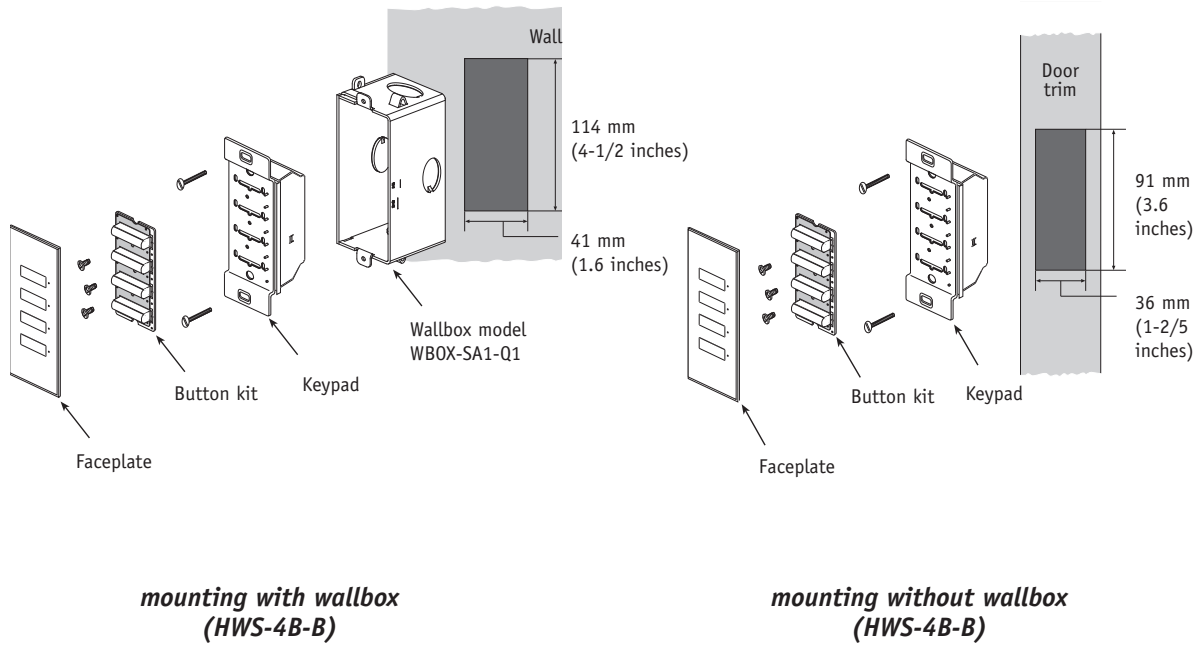


Figure 3 – Signature Series mounting diagrams

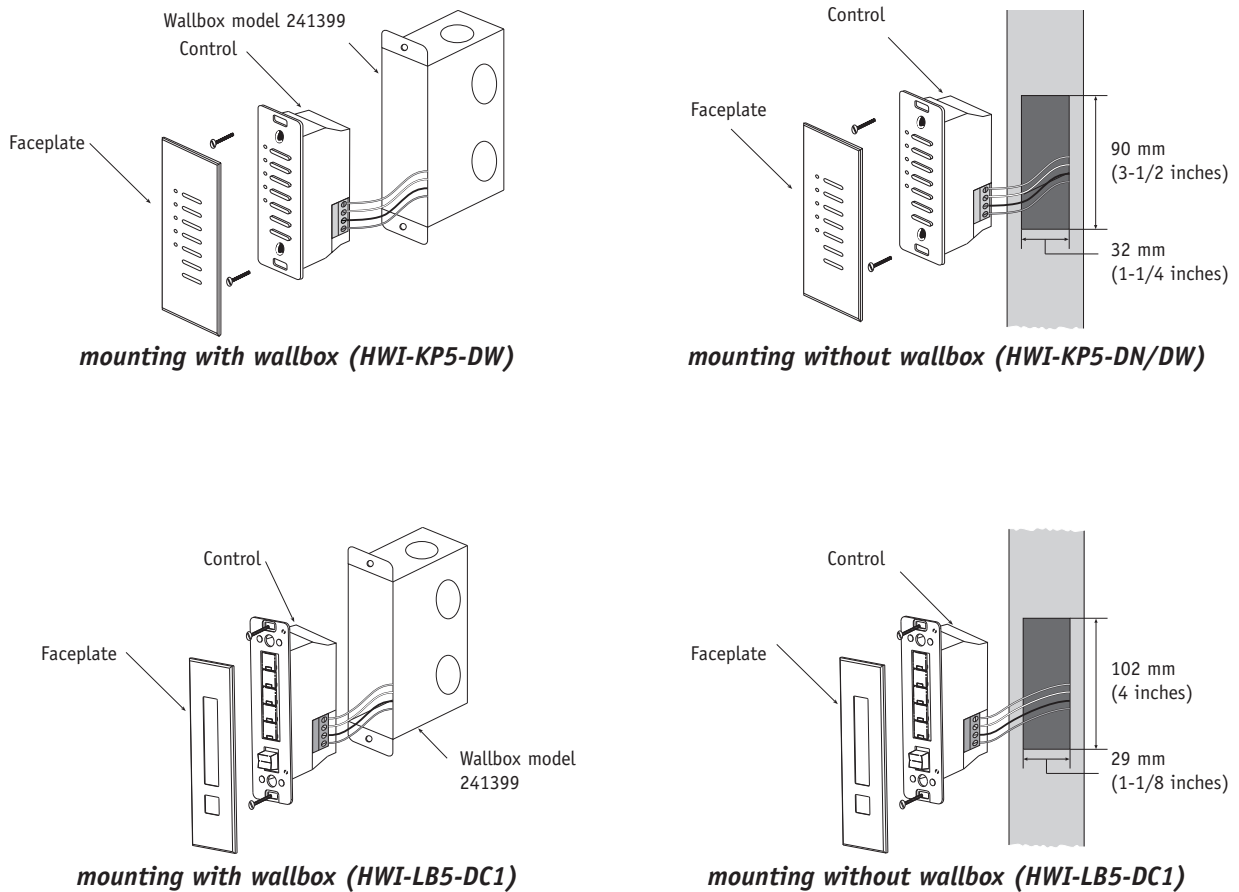


Figure 4 – Architrave mounting diagrams

# Engraving with Icons




























































## ICONS

Images or icons can be placed directly on seeTouch® keypad buttons. The table below displays each icon with an identifier number. When specifying button engraving that includes Lutron® standard icons, input the identifier code for each button in the appropriate space on the engraving sheet.

Please note that using icons takes up an additional two characters on each button on average.

You can review instructions for engraving icons at <http://resi.lutron.com>

## ICON TABLE

01. 	17. 	33. 	49. 
02. 	18. 	34. 	50. 
03. 	19. 	35. 	51. 
04. 	20. 	36. $\frac{1}{4}$	52. 
05. 	21. 	37. $\frac{1}{2}$	53. 
06. 	22. 	38. $\frac{3}{4}$	54. 
07. 	23. 	39. 	55. 
08. 	24. 	40. 	56. 
09. 	25. 	41. 	57. 
10. 	26. 	42. 	58. 
11. 	27. 	43. 	59. 
12. 	28. 	44. 	60. 
13. 	29. 	45. 	61. 
14. 	30. 	46. 	62. 
15. 	31. 	47. 	
16. 	32. 	48. 	

# Wallbox Closure Interface

The Wallbox Closure Interface (model HWI-WCI) provides seven contact closure inputs and installs in a standard European wallbox. The HWI-WCI interfaces with low-voltage switches to provide an alternative look from a HomeWorks® keypad. The contact closure inputs are programmed using the *HomeWorks* software.

## **ENVIRONMENT**

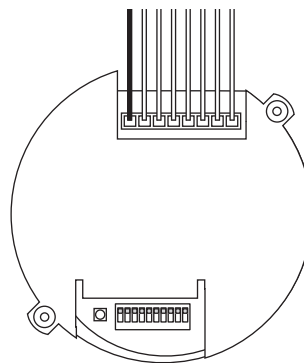
Ambient temperature: 0 °C to 40 °C (32 °F to 104 °F), 0-90% humidity, non-condensing. Indoor use only.

## **CONNECTION TO PROCESSOR**

HWI-WCI link wiring may be in a daisy-chain, star or T-tap configuration. Each home run on a link may be up to 305 m (1,000 feet) and may contain up to 10 HWI-WCI devices. The total length of wire on that link (all home runs) may be up to 1220 m (4,000 feet). 32 WCI devices may be placed on each processor link configured as a keypad link in the *HomeWorks* software. An auxiliary power supply may be required depending on the total current draw of all devices on the processor.

## **CONTACT CLOSURE INPUTS**

Verify compatibility of external equipment. The input closures are intended for use with equipment that provide outputs in the form of dry contact closures. The HWI-WCI is for use with low-voltage switches only. Switches rated for high-voltage applications may not be used. The input closures may be used with ground-referenced, solid-state outputs if the outputs have an on-state saturation voltage of less than 2 VDC and an off-state leakage of less than 50 µA. Dry contact or solid-state outputs must be capable of switching 15 VDC at 10 mA. The outputs must stay in the closed or open states for at least 40 msec in order to be recognized by the keypad.



**HWI-WCI**



# Wallbox Closure Interface

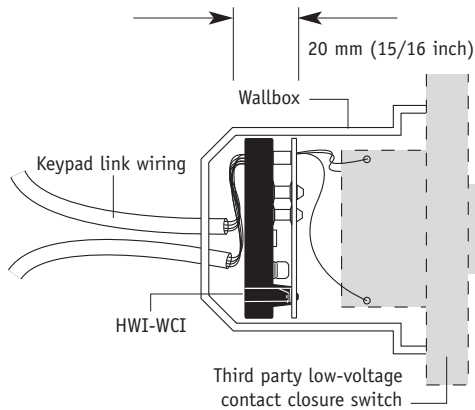


Figure 1 – mounting diagram

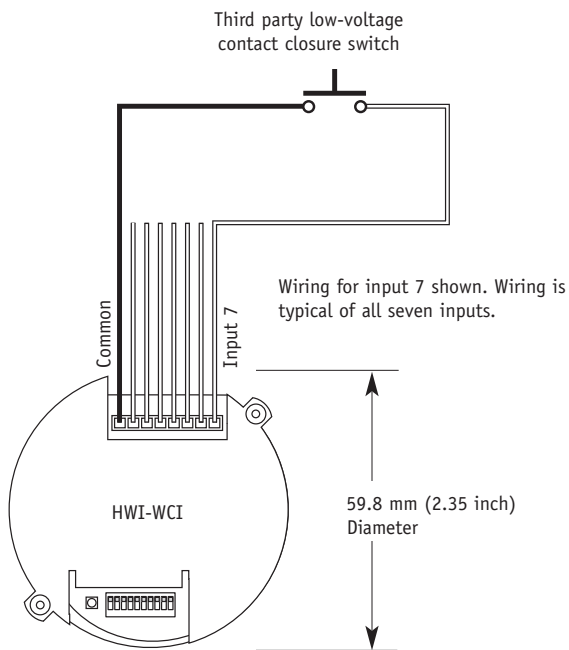
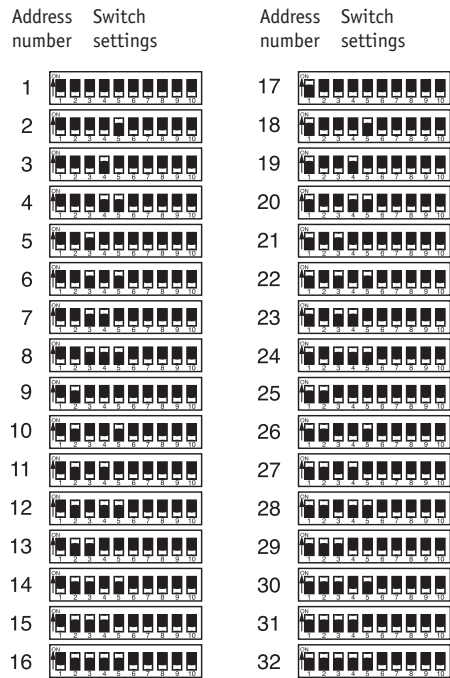
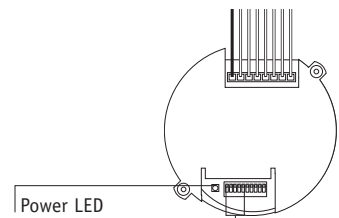
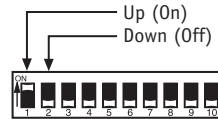


Figure 2 – Contact Closure Input wiring diagram



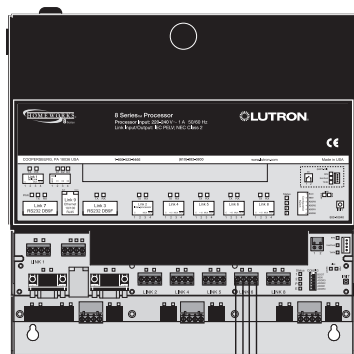
Set DIP switches 1-5 to give the Wallbox Closure Interface a unique HomeWorks® system address from 1 to 32.

Example: setting switch 1 on.



DIP switches 1-5 for setting address. DIP switches 6-10 do not affect Wallbox Closure Interface address.

Figure 3 – addressing



HomeWorks processor

- 10 keypads max per home run
- 32 keypads max per keypad link
- 1 220 m max wire length per processor link

Wallbox Closure Interfaces can be connected to any link configured as an HomeWorks Keypad Link.

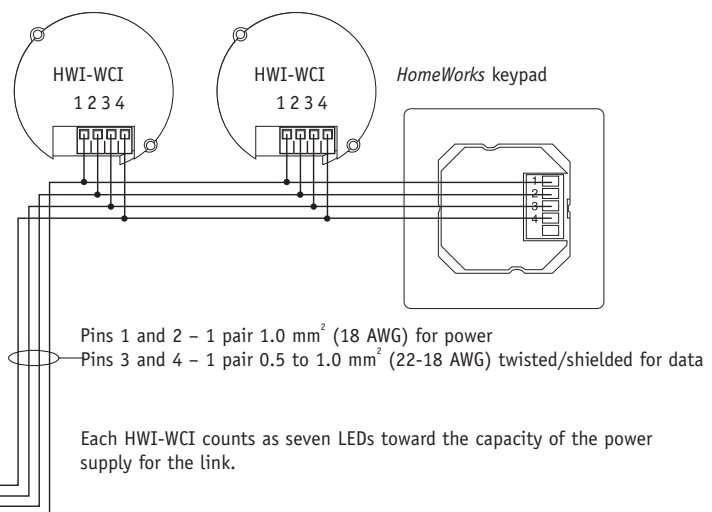


Figure 4 – wiring diagram

Each HWI-WCI counts as seven LEDs toward the capacity of the power supply for the link.

# Web Keypads

The web keypads allow the homeowner to control the HomeWorks® system from a computer using a web browser. The homeowner will be able to monitor and control selected keypads in the system. Web keypads can simulate actual keypads in the home or provide special functions only possible from the computer.

The web keypads can be accessed from most popular web browsers including Internet Explorer 6.0 or later, Mozilla Firefox, and Safari. The web keypads will work on any browser that supports Javascript 1.2, Cascading Style Sheets and a screen with a minimum resolution of 800 x 600. Palm Pilots and Pocket PCs are not currently supported.



# Keypad Specifications and Addressing

Model	All keypads.
Input voltage	15 V $\overline{\text{DC}}$ Class 2/PELV
Environment	Ambient temperature: 0 °C to 40 °C, 32 °F to 104 °F Ambient humidity: 0-90% humidity, non-condensing. Indoor use only.
Low-voltage wire type	Two pair [one pair 1.0 mm <sup>2</sup> (18 AWG), one pair 1.0 to 0.5 mm <sup>2</sup> (18-22 AWG) twisted shielded] Class 2/PELV wire. Lutron® wire model GRX-CBL-346S-500 may be used.
Low-voltage wiring configuration	Daisy-chain, star, T-tap. Termination not required. Total length of wire on any link cannot exceed 305 m (1,000 feet) per wire run. Total length of wire on that link cannot exceed 1220 m (4,000 feet). Maximum of 32 devices per processor link that has been configured for keypads.
Low-voltage connections	One 4-pin removable terminal block. Terminal block will accept up to four 1.0 mm <sup>2</sup> (18 AWG) wires.
Addressing	Via DIP switch located on unit. Units should be addressed before mounting in wall.
Diagnostics	LEDs provide diagnostics for troubleshooting.
ESD protection	Meets or exceeds the IEC 61000-4-2 standard.
Surge protection	Meets or exceeds ANSI/IEEE standard c62.41.
Miswire protection	All terminal block inputs are over-voltage and miswire-protected against wire reversals and shorts.
Mounting	See table 1, page 5.34.
Engraving	Engraving of keypads and/or keypad buttons available.
IR keypads	Compatible with Lutron IR transmitters: GRX-IT-WH, and GRX-8IT-WH.
Shipping weight	0.1 kg (0.4 pounds)
Keypad link LED count	See table 1, page 5.34.

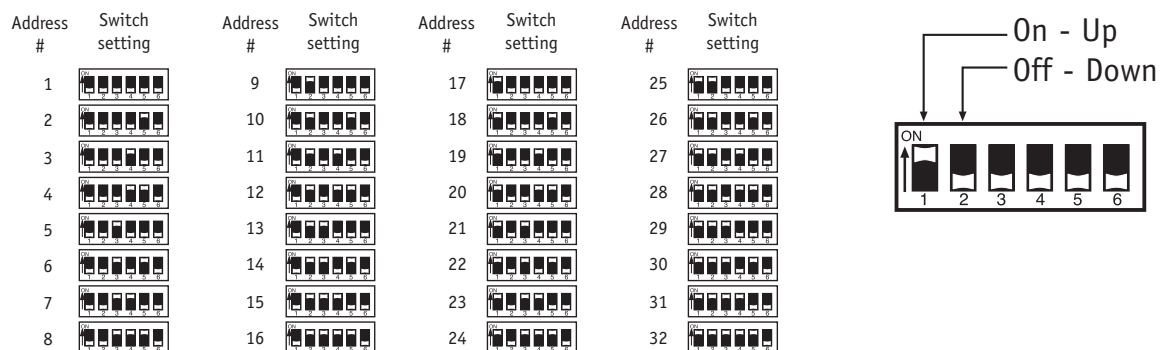


Figure 1 –addressing DIP switches

# Wired Keypads – Addressing DIP Switch Locations

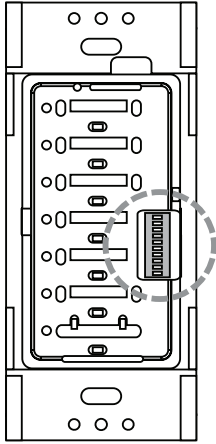


Figure 2 – seeTouch® Keypads Front View

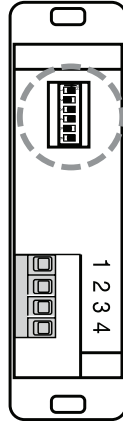


Figure 3 – Signature Series™ and Architrave™ Keypads Rear View

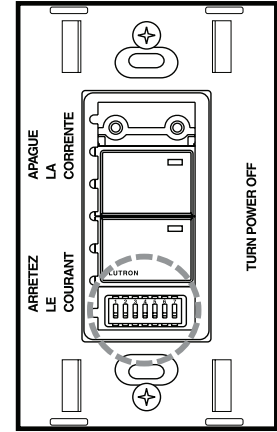


Figure 4 – 2-Button Keypad Front View

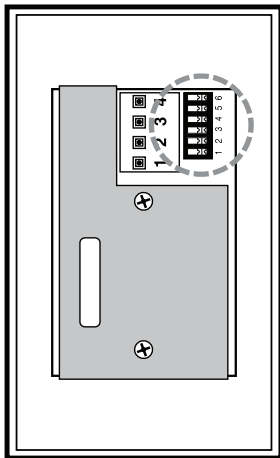


Figure 5 – Architectural-style Slim and Large Button Keypads Rear View

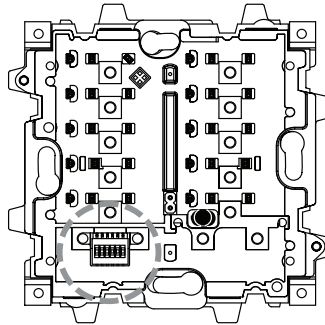


Figure 6 – International seeTouch Keypads Front View

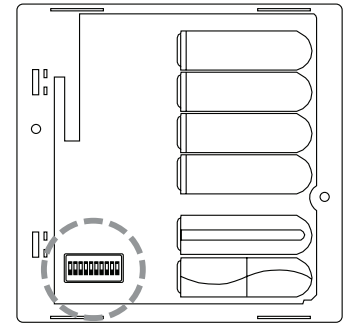


Figure 7 – European-style Keypads Front View

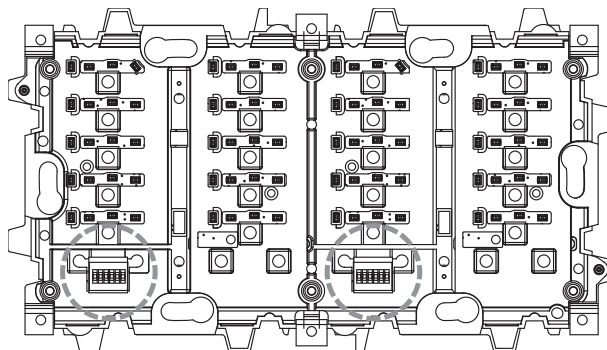
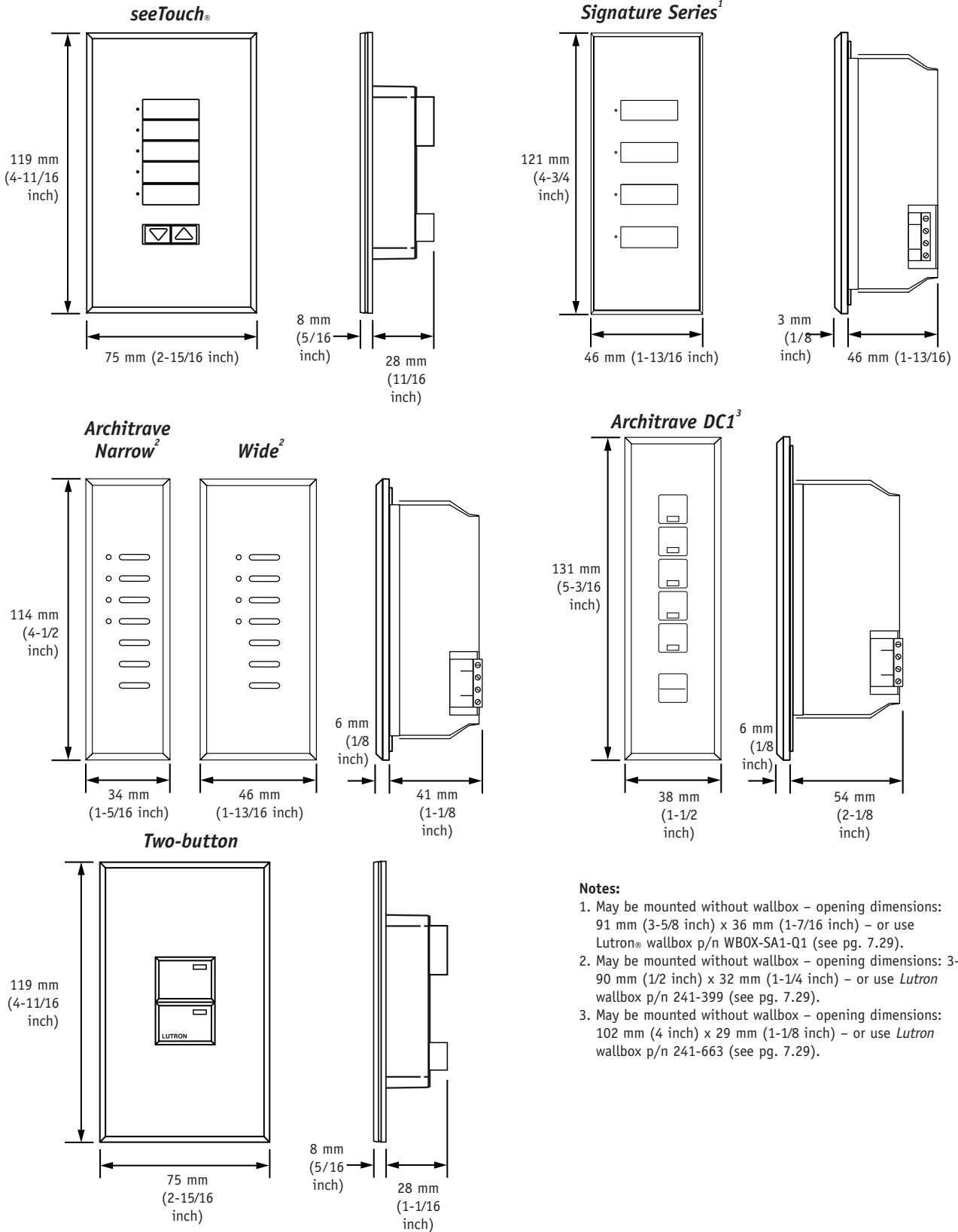


Figure 8 – Dual International Keypads Front View

# Wired Keypads – Dimensions

Architectural-style Keypads Dimensions - all dimensions are mm (inches)



**Notes:**

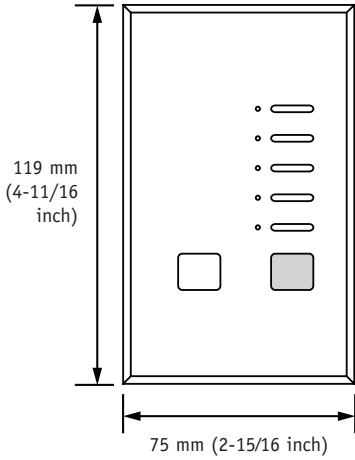
1. May be mounted without wallbox – opening dimensions: 91 mm (3-5/8 inch) x 36 mm (1-7/16 inch) – or use Lutron® wallbox p/n WBOX-SA1-Q1 (see pg. 7.29).
2. May be mounted without wallbox – opening dimensions: 3-90 mm (1/2 inch) x 32 mm (1-1/4 inch) – or use Lutron wallbox p/n 241-399 (see pg. 7.29).
3. May be mounted without wallbox – opening dimensions: 102 mm (4 inch) x 29 mm (1-1/8 inch) – or use Lutron wallbox p/n 241-663 (see pg. 7.29).

FRONT ROOM EQUIPMENT

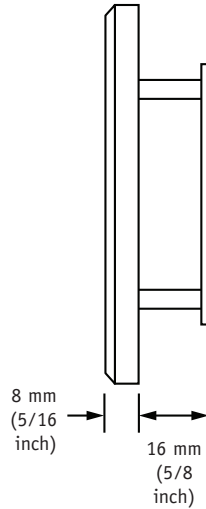
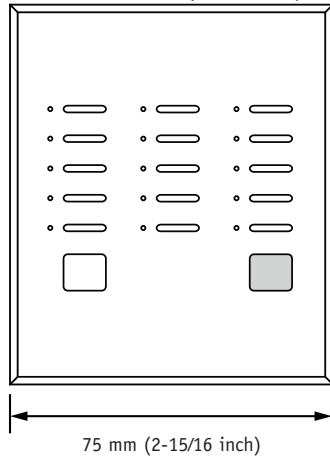
# Wired Keypads – Dimensions (cont'd)

## Architectural-style Keypads Dimensions

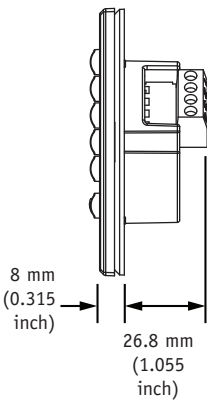
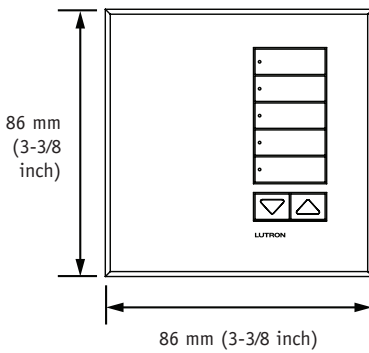
**Slim Button (5 & 10 button)  
Large Button (6 button)  
Two Button**



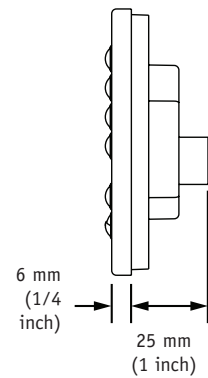
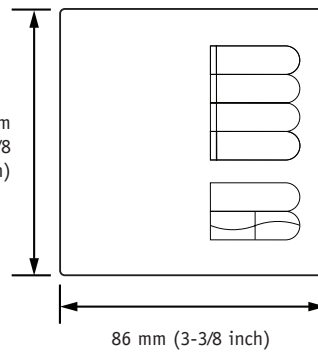
**Slim Button (15 button)  
Large Button (9 button)**



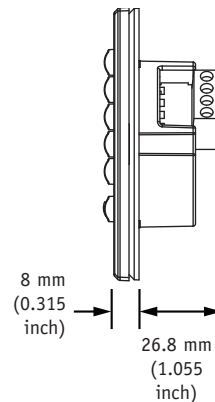
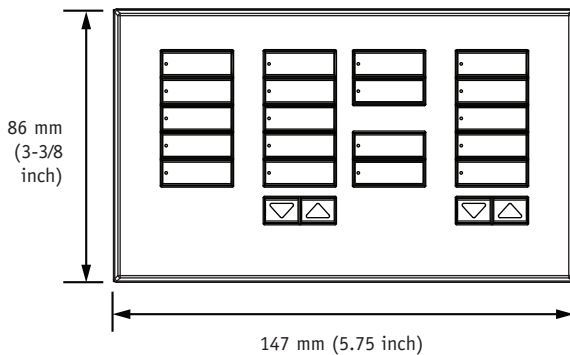
**International seeTouch®**



**European-style**

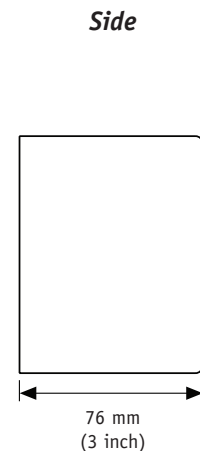
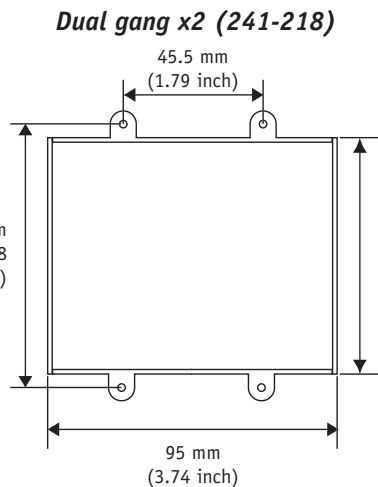
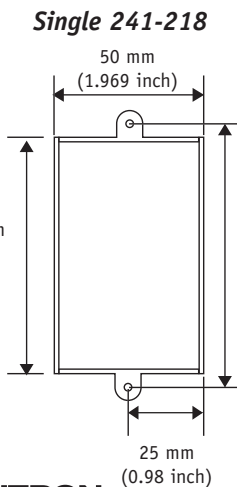
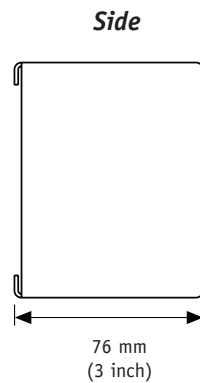
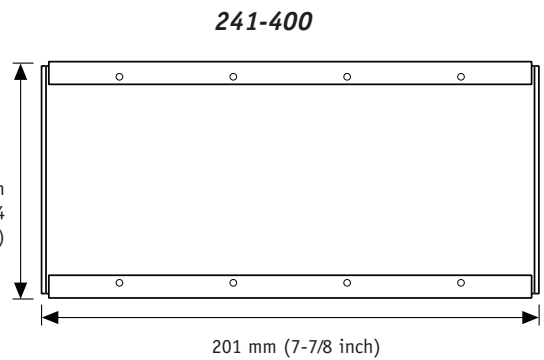
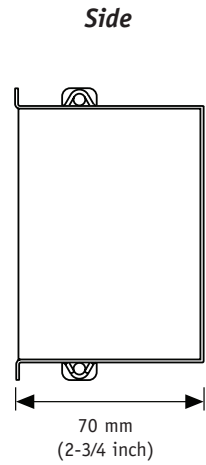
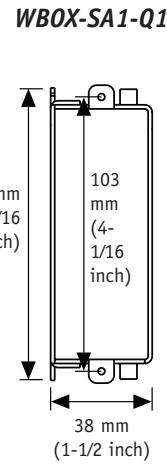
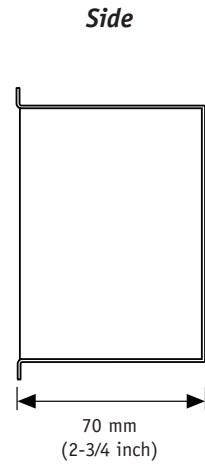
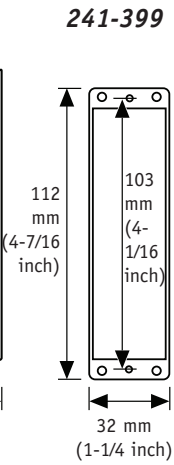
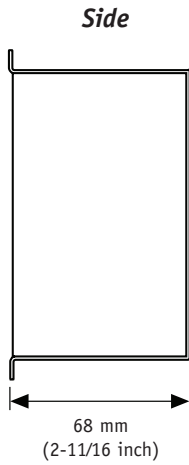
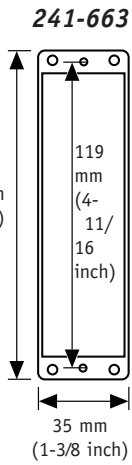
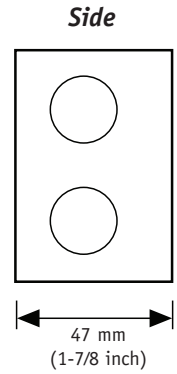
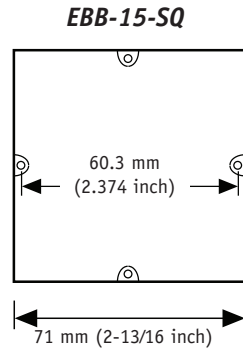
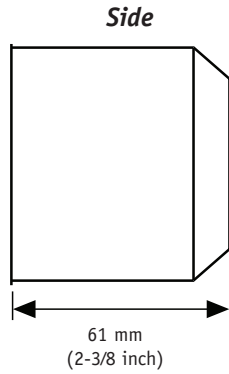
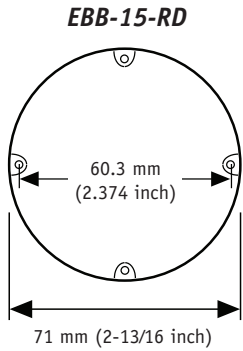


**Dual International**



# Wallbox Dimensions

## Wallbox Dimensions



# Specifications

<b>Control</b>	<b>LED Count</b>	<b>Wallboxes Required</b>
HWI-2SE	3	European-style (241683)
HWI-4SE	4	European-style (241683)
4SE-IR	4	European-style (241683)
HWI-8SE	8	European-style (241683)
HWBO-4SE	4	European-style (241683)
HWBO-8SE-IR	8	European-style (241683)
International <i>seeTouch</i> ® (all models)	15	European-style (241683)
Dual International <i>seeTouch</i>	30	2-gang UK/European
<i>seeTouch</i> (all models)	15	1-gang US (241218)
HWI-KP5	5	1-gang US (241218)
HWI-KP10	10	1-gang US (241218)
HWI-KP15	15	2-gang US (241218)
HWI-LB6	6	1-gang US (241218)
HWI-LB9	9	2-gang US (241218)
HWI-LB5-DC1	5	Not required or Lutron® 241663
HWI-KP5-DN	5	Not required or Lutron 241399
HWI-KP5-DW	5	Not required or Lutron 241399
HWI-5S-M	5	1-gang US (241218)
HWI-5S-NM	5	1-gang US (241218)
HWI-5S-IR	5	1-gang US (241218)
HWI-2B	10	1-gang US (241218)
HWS-3B-G	10	Not required or WBOX-SA1-Q1
HWS-4B-G	10	Not required or WBOX-SA1-Q1
HWS-3B-B	10	Not required or WBOX-SA1-Q1
HWS-4B-B	10	Not required or WBOX-SA1-Q1
HWI-CCI-8	10	n/a
HWI-CCO-8	10	n/a
HWI-WCI	7	n/a
HWI-HHP-LD	45	n/a
HR-REP-	15	n/a

**Table 1 – keypad LED count and wallbox information**

**Notes:**

A single 8 series P5 processor can support 350 keypad LEDs. This includes all keypads on the three configurable links (link 4, 5, and 6). If more than 350 LEDs are placed on a single 8 series processor, an auxiliary power supply must be used. *See pages 12.4-12.6* for auxiliary power supply specifications.

Link 6 on a 4 series processor can support 150 keypad LEDs. If more than 150 LEDs are used on link 6, an auxiliary power supply must be used. Links 4 and 5 on a 4 series processor always require an auxiliary power supply if keypads are to be used. *See pages 12.4-12.6* for auxiliary power supply specifications.



---

# Power Modules and Remote Power Panels

# Wallbox Power Module

HomeWorks® Wallbox Power Modules (WPM) control six zones of lighting. The WPM is designed to be located in closets, equipment rooms, and other locations in the home where it is “hidden” from view. Clients use keypads to control the lights connected to the WPM.

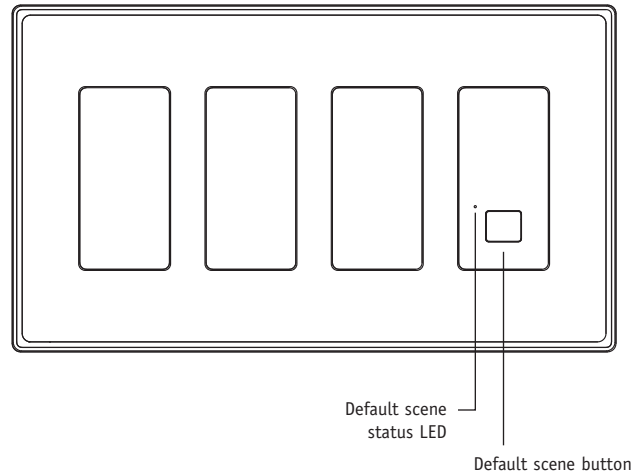
## **CONNECTION TO PROCESSOR**

The WPM is wired like a six-zone GRAFIK Eye® control unit (GRX-3506). Each HomeWorks processor has three configurable links each capable of controlling up to eight WPM or GRAFIK Eye control units. This connection requires two pair [one pair 1.0 mm<sup>2</sup> (18 AWG), one pair 0.5 to 1.0 mm<sup>2</sup> (18-22 AWG) twisted shielded] Class 2/PELV wire. Lutron® wire model GRX-CBL-346S-500 may be used. The maximum cable length is 610 m (2,000 feet), and this link must be wired in a daisy-chain configuration.

The wattage and load type specifications of the WPM are the same as six-zone GRAFIK Eye control unit (GRX-3106/3506 models). All connections on the back of the WPM are identical to those on the six-zone GRAFIK Eye control unit.

## **DEFAULT SCENE BUTTON**

Each WPM has a default scene button on the front that allows a user to toggle between a preset scene and OFF. This scene is stored inside the WPM and can be activated at any time. The default scene provides “fail-safe” operation allowing the WPM to be controlled locally if communication to the processor is lost.



**Wallbox Power Module**

## **WPM BENEFITS:**

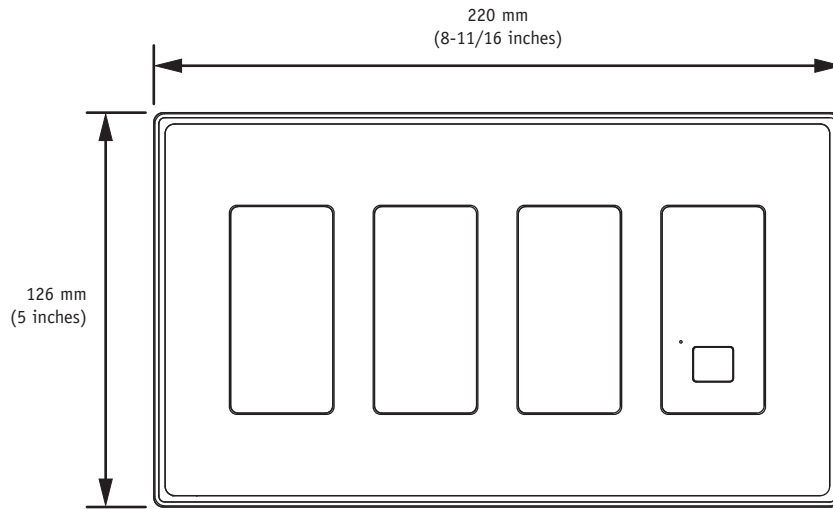
- Minimises the number of controls on the wall
- Provides a cost-effective dimming solution to jobs with lower wattage loads
- Reduces overall job cost by up to 5-20% when less than 96 control zones are required
- Install in areas where available space is minimal

**Note:** Use 89 mm (3-1/2 inches) deep wallboxes for ease of installation of GRAFIK Eye control units.

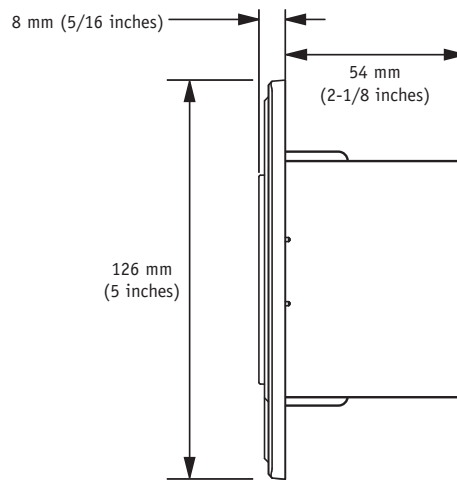
# Wallbox Power Module

<b>Control Units</b>	
Model	HWI-WPM-6D-230CE: control six zones of lighting. (CE compliant) HWI-WPM-6D-240: control six zones of lighting. (non-CE)
Input voltage	220-240 V ~ 50/60 Hz
Regulatory approvals	CE, C-Tick (CE compliant model)
Load types	Incandescent, magnetic low-voltage, electronic low-voltage (requires Lutron® low-voltage transformers), fluorescent non-dim, neon/cold cathode. The outputs are also compatible with <i>Lutron Power Boosters</i> and interfaces in <i>section 6</i> .
Maximum load (CE)	2200 W/VA per control unit, 800 W/VA per zone.
Maximum load (non CE)	3000 W/VA per control unit, 1200 W/VA per zone.
Minimum load	25 W/VA per zone.
Environment	Ambient temperature: 0°C to 40 °C, 32 °F to 104 °F Ambient humidity: 0-90% humidity, non-condensing. Indoor use only.
Cooling method	Passive cooling.
Line-voltage connections	See <i>figure 3 and 4, page 4.20</i> .
Low-voltage wire type	Two pair [one pair 1.0 mm <sup>2</sup> (18 AWG), one pair 0.5 to 1.0 mm <sup>2</sup> (18-22 AWG) twisted shielded] Class 2/PELV wire. <i>Lutron</i> wire model GRX-CBL-346S-500 may be used.
Low-voltage wiring configuration	Maximum of 610 m (2,000 feet) total. Must be wired in a daisy-chain configuration. See <i>figure 5, page 6.5</i> .
Low-voltage connection	One 4-pin removable terminal block. Each of the four terminals will accept up to two 1.0 mm <sup>2</sup> (18 AWG) wires. Do not connect terminal 2 on processor communication link connector or between WPM units.
Addressing	Via rotary dial. Use 1 of 8 addresses on a GRAFIK Eye®/WPM link.
ESD protection	Meets or exceeds the IEC 61000-4-2 standard.
Surge protection	Meets or exceeds ANSI/IEEE standard c62.41.
Air gap	Provided when all circuits are off.
Power-failure memory	Non-volatile RAM.
Fail-safe operation	If communication with the processor is interrupted, all Wallbox Power Modules will still allow local control.
Dimensions	See <i>figures 1 and 2, page 6.4</i> .
Mounting	4-gang US wallbox, 70 mm (2-3/4 inches) deep minimum, 89 mm (3-1/2 inches) deep recommended for ease of wiring. If mounting one control above another, leave at least 11.4 cm (4-1/2 inches) vertical spacing between them. <i>Lutron</i> model 241400 may be used.
Shipping weight	0.9 kg (2.0 pounds)

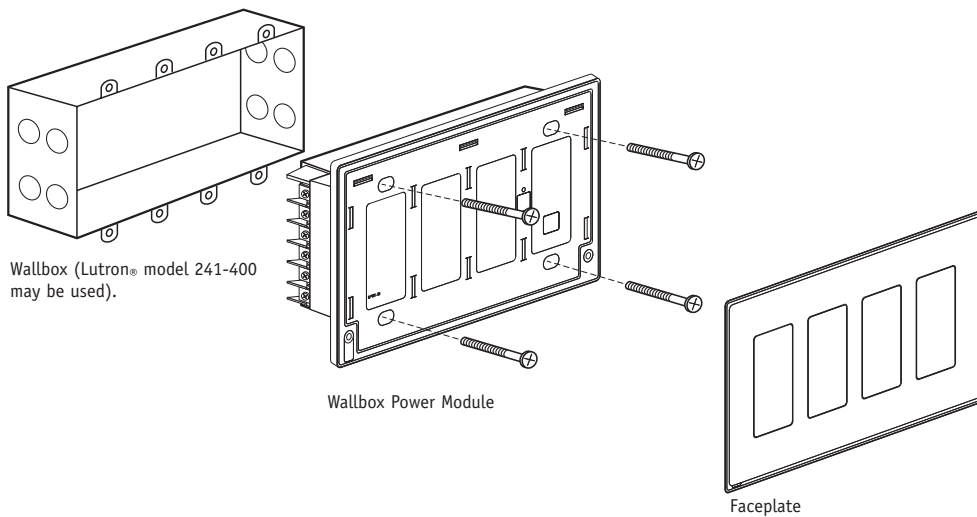
# Wallbox Power Module



**Figure 1 – front view**

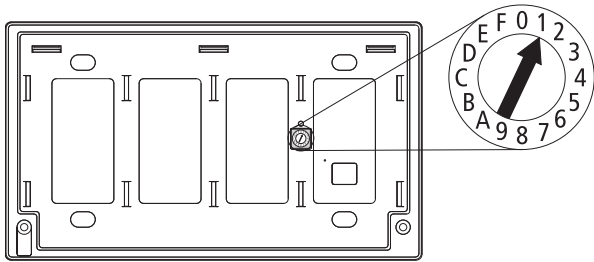


**Figure 2 – side view**



**Figure 3 – mounting**

# Wallbox Power Module

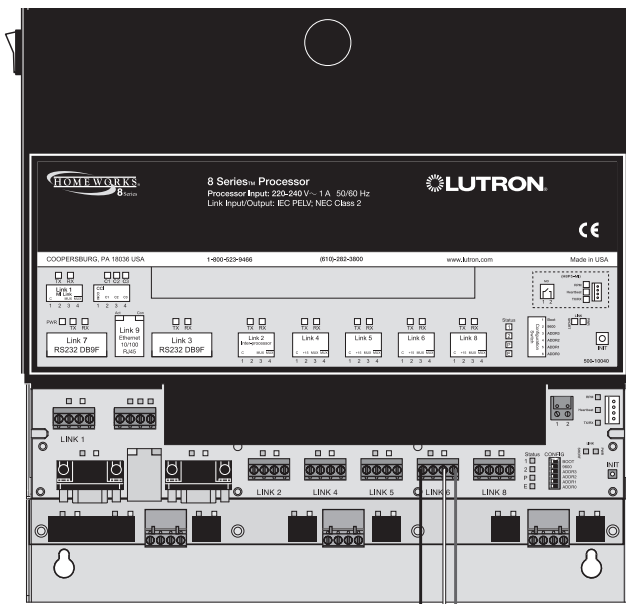


**Figure 4 – rotary address switch location**  
(faceplate removed)

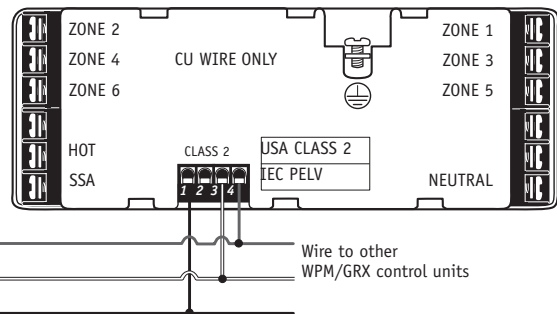
**Position Proper module output/purpose**

0	All outputs OFF
1-8	Address for normal operation
9	Output 1 full ON, all others OFF
A	Output 2 full ON, all others OFF
B	Output 3 full ON, all others OFF
C	Output 4 full ON, all others OFF
D	Output 5 full ON, all others OFF
E	Output 6 full ON, all others OFF
F	All outputs full ON

**Table 1 – rotary address dial operation**



Pin 1 - One 1.0 mm<sup>2</sup> (18 AWG) for common  
Pin 2 - Do not connect  
Pins 3 and 4 - One pair 1.0 to 0.5 mm<sup>2</sup> (18-22 AWG) twisted/shielded for data



**Figure 5 – connection to processor**

# Remote Power Modules

HomeWorks® Remote Power Modules (RPMs) are used in both centralised and hybrid system designs to control lighting, motor, and fan loads. There are several different models of RPMs; each model controls specific load types. The RPMs are mounted in one of the Remote Power Panels.

## **DIMMING MODULE**

### **(MODEL HW-RPM-4U-230-CE)**

The dimming module has 4 outputs that can dim or switch incandescent, magnetic low-voltage electronic low-voltage (requires Lutron® low-voltage transformers) or neon/cold cathode. Each of the four outputs can switch electronic low-voltage or fluorescent lighting. The total capacity of a dimming module is 13 A @ 230 V $\sim$  (3680 W/VA)<sup>2</sup>. The maximum capacity of any single zone is 10 A.

## **DIMMING MODULE**

### **(MODEL HW-RPM-4U-240 [NON-CE])**

This module has the same characteristics as the above model except this module has a total capacity of 16 A @ 220-240 V $\sim$ . The maximum capacity of any single output is also 16 A.

## **MOTOR MODULE**

### **(MODEL HW-RPM-4M-230)**

The motor module can control four 3-wire 230 V $\sim$  AC motors for applications such as shades, draperies, and curtains. Each motor control uses two mechanically interlocked relays for directional control that prevents simultaneous operation of both outputs. Maximum relay contact rating is 1/2 HP, 5 A @ 230 V $\sim$  for inductive loads, and 1.5 A @ 230 V $\sim$  for resistive loads.

## **POWER RELAY MODULE**

### **(MODEL HW-RPM-4R)**

The power relay module has 4 outputs that can switch incandescent, neon/cold cathode, magnetic low-voltage, electronic low-voltage, fluorescent, or high intensity discharge (HID). The total capacity of a power relay module is 64 A @ 220-240 V $\sim$ . The total load capacity of any individual output is limited to 16 A @ 220-240 V $\sim$ , 5 A for motor loads.

## **ADAPTIVE DIMMING MODULE**

### **(MODEL MODEL HW-RPM-4A-230)**

The adaptive dimming module has 4 outputs that can dim incandescent, magnetic low-voltage, electronic low-voltage or neon/cold cathode and switch LEDs up to 300 W per zone. The adaptive module uses our RTISS®-TE technology to supply stable power to the lights even in harsh power line conditions. The total load capacity of the module is 13 A @ 230 V $\sim$  (2990 W). The total load capacity of any individual output is 8 A (1840 W).

The adaptive dimming module is ideal for applications where power conditions are non-ideal such as yachts and ships. The adaptive dimming module may be used with any combination of other Remote Power Modules within a HomeWorks Remote Power Panel.

## **CONNECTION TO MODULE INTERFACE**

All RPMs must be connected to a Module Interface located within the same Remote Power Panel. If a processor is located in the same panel as RPMs, a processor with an integral Module Interface must be used (either model H8P5-MI-CE and H8P5-MI-H48-CE). RPMs within an enclosure are connected to the Module Interface using a wire harness provided by Lutron®.

# Remote Power Modules

<b>HW-RPM-4U-230-CE, HW-RPM-4U-240 • dimming module</b>	
Load types	Incandescent, magnetic low-voltage, electronic low-voltage (requires Lutron® low-voltage transformers) neon/cold cathode, fluorescent non-dim. The outputs are compatible with <i>Lutron Power Boosters</i> and interfaces in <i>section 6</i> .
Maximum load	CE model: 13 A total, 8 A maximum per output. Non-CE model: 16 A total, 16 A maximum per output.
Wiring	Terminal blocks in the power panel will accept one 1.0 to 2.5 mm <sup>2</sup> (18-10 AWG) wire or two 1.0-1.5 mm <sup>2</sup> (18-16 AWG) wires. <i>See figure 1, page 6.10.</i>
Technology	Forward phase control using triac technology. Equipped with RTISS®, Real Time Illumination Stability System.
Interference suppression	EMI/RFI suppression circuitry.
Air gap	Provided when all four circuits are off.

<b>HW-RPM-4A-230 • adaptive dimming module</b>	
Load types	Incandescent, magnetic low-voltage, electronic low-voltage, non-dim LEDs (up to 300 W per zone), and neon/cold cathode. The outputs are compatible with <i>Lutron® Power Boosters</i> and interfaces.
Maximum load	13 A total, 8 A maximum per per output.
Wiring	Terminal blocks in the power panel will accept one 1.0 to 2.5 mm <sup>2</sup> (18-10 AWG) wire or two 1.0 to 1.5 mm <sup>2</sup> (18-16 AWG) wires.
Technology	Forward and reverse phase control using FET technology. Equipped with RTISS®-TE, Real Time Illumination Stability System enhanced for Trailing Edge dimming. Contains limited short-circuit and overload protection.
Interference suppression	EMI/RFI suppression circuitry.
Air gap	Provided when all four circuits are off.

# Remote Power Modules

<b>HW-RPM-4M-230 • motor module</b>	
Load types	Bi-directional three-wire 120 V motor loads, or incandescent non-dim. Outputs are not rated for switching electronic low-voltage or electronic ballasts.
Maximum load	1/2 HP per circuit. 5 A maximum per circuit for motor loads, 1.5 A maximum per circuit for tungsten loads.
Wiring	Terminal blocks will accept one 1.0 to 2.5 mm <sup>2</sup> (18-10 AWG) wire or two 1.0 to 1.5 mm <sup>2</sup> (18-16 AWG) wires. Requires that four additional terminal blocks be mounted onto the DIN rail assembly. <i>See figure 2, page 6.10.</i>
Technology	Relay switching, mechanical-interlocked relays guarantee motor protection.
Interference suppression	EMI/RFI suppression circuitry.
Air gap	Provided when all four circuits are off.

<b>HW-RPM-4R • power relay module (100-277 V)</b>	
Load types	Non-dim loads.
Maximum load	64 A total, 16 A, maximum per output (5 A for motor loads).
Wiring	Terminal blocks will accept one 1.0 to 2.5 mm <sup>2</sup> (18-10 AWG) wire or two 1.0 to 1.5 mm <sup>2</sup> (18-16 AWG) wires. Requires the installation of four additional gray terminal blocks and three additional black terminal blocks to be mounted on to the DIN rail assembly. Gray terminal blocks accept one 0.75 to 10 mm <sup>2</sup> (18-8 AWG) wire or two 1.5 to 4.0 mm <sup>2</sup> (16-12 AWG) wires. <i>See figure 3, page 6.10.</i>
Technology	Patented Softswitch® triac arc suppression technology used to extend relay life.
Interference suppression	EMI/RFI suppression circuitry.
Air gap	Provided when all four circuits are off.



# Remote Power Modules

<b>All Remote Power Modules</b>	
Model	HW-RPM-4U-230-CE: dimming module CE compliant. HW-RPM-4U-240: dimming module (non-CE). HW-RPM-4M-230: motor module. HW-RPM-4R: power relay module. HW-RPM-4A-230: adaptive dimming module.
Input voltage	RPM-4U, RPM-4M, RPM-4A: 220-240 V ~ 50/60 Hz RPM-4R: 100-277 V ~ 50/60 Hz
Number of outputs	4
Regulatory approvals	CE, C-TICK (except HW-RPM-4U-240)
Environment	Ambient temperature: 0 °C to 40 °C (32 °F to 104 °F) Ambient humidity: 0-90% humidity, non-condensing. Indoor use only.
Cooling method	Passive cooling.
Heat generated fully loaded	4A, 4U modules will generate up to 82 BTUs per hour when fully loaded. 4R, 4M modules will generate up to 18 BTUs per hour when fully loaded.
Line-voltage connections	Separate line-voltage feeds at the DIN rail terminal blocks for each RPM. Terminal blocks should be tightened to 0.40-0.57 n·m (3.5-5.0 inch-pounds).
Low-voltage communications	Communication harness provided by Lutron®.
Addressing	Rotary switch. Counts as 1 of 8 RPM addresses per MI.
Diagnostics	LED provided to indicate proper communications with Module Interface.
ESD protection	Meets or exceeds the IEC 61000-4-2 standard.
Surge protection	Meets or exceeds ANSI/IEEE standard c62.41.
Fail-safe operation	Rotary switch on the RPM allows for manual operation of each load.
Dimensions	99 mm (3-7/8 inches) wide x 178 mm (7 inches) high
Mounting	HWI-PNL-8 and the HWBP-8D Remote Power Panels will hold up to 8 RPMs. HWI-PNL-5 Remote Power Panel will hold up to 5 RPMs. <b>Note:</b> RPMs may hum slightly and internal relays will click when in use. Mount where such noise is acceptable. Locate at least 1.8 m (6 feet) away from sensitive electronic equipment.
Shipping weight	1.0 kg (2.2 pounds)
Minimum load	HW-RPM-4U: 25 W/VA per output HW-RPM-4A: 10 W/VA per output

# Remote Power Modules – Wiring Diagrams

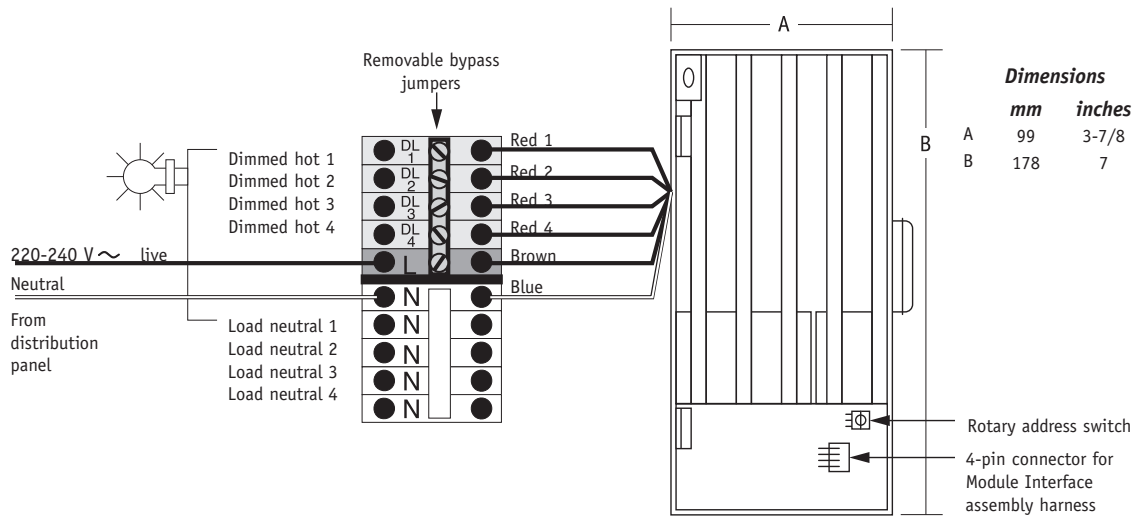


Figure 1 – HW-RPM-4U-230-CE, HW-RPM-4U-240, and HW-RPM-4A-230

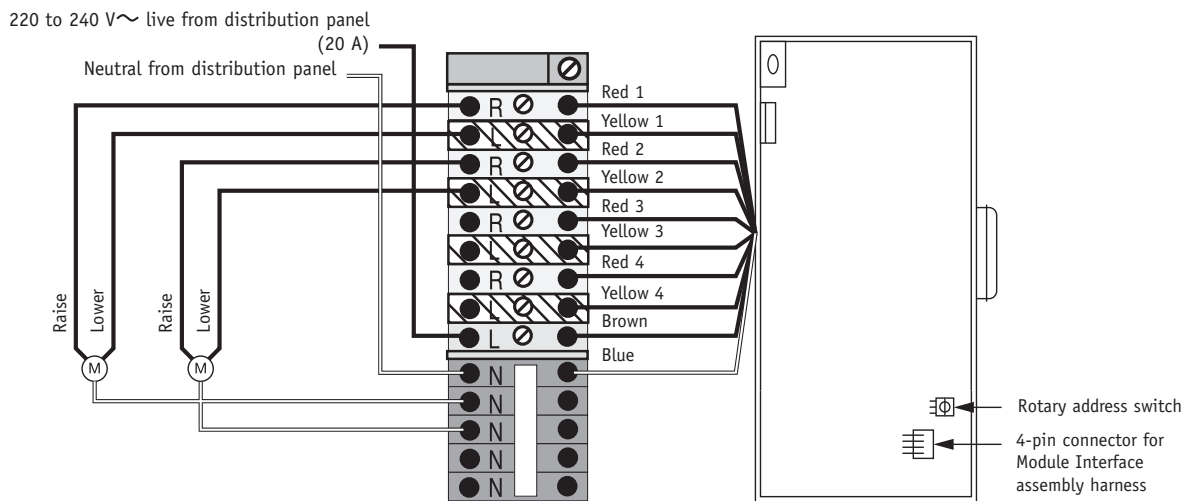


Figure 2 – HW-RPM-4M-230

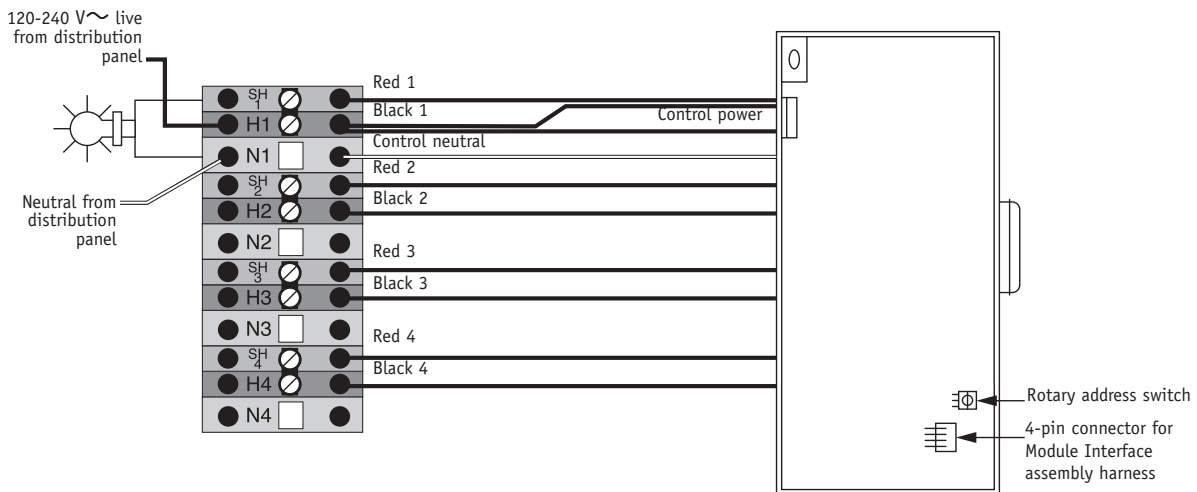
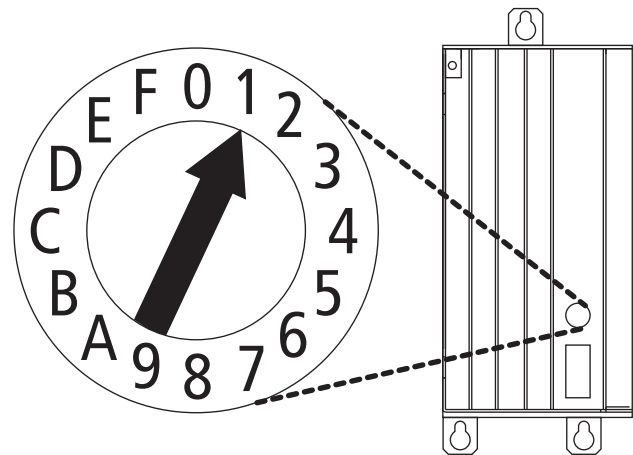


Figure 3 – HW-RPM-4R

# Remote Power Modules – Rotary Address Switch



*Enlarged view of rotary address switch*

**ROTARY ADDRESS SWITCH POSITION  
FOR HW-RPM-4U, 4R, 4A**

<b><i>Position</i></b>	<b><i>Module output/purpose</i></b>
0	All outputs OFF
1-8	Address for normal operation
9, A	Not used
B	Output 1 ON use for temporary lighting and/or zone testing
C	Output 2 ON use for temporary lighting and/or zone testing
D	Output 3 ON use for temporary lighting and/or zone testing
E	Output 4 ON use for temporary lighting and/or zone testing
F	All outputs ON use for temporary lighting and/or zone testing

**ROTARY ADDRESS SWITCH POSITION  
FOR HW-RPM-4M**

<b><i>Position</i></b>	<b><i>Module output/purpose</i></b>
0	All relays OFF
1-8	Address for normal operation
9, A-D	Not used
E	All raise relays ON use for directional motor testing
F	All lower relays ON use for directional motor testing

# Module Interface

Module Interfaces control up to eight RPMs and are available in two configurations: either integral to a HomeWorks® processor or as a stand-alone component. Each HomeWorks 8 series processor can control up to 16 Module Interfaces.

## **STAND-ALONE MODULE INTERFACE (MODEL HWI-MI-230)**

A stand-alone Module Interface controls up to eight RPMs in a Remote Power Panel that does not contain a processor. A stand-alone Module Interface installs in HWI-PNL-8-CE, HWI-PNL-5-CE, PBK8-40-13-CE or PBK8-40-13-10-CE.

## **INTEGRAL MODULE INTERFACE**

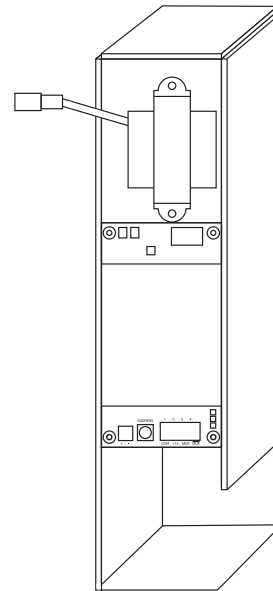
Some 8 series processor models (model HWI-PM-230, H8P5-MI-CE and H8P5-MI-H48-CE) contain integral Module Interfaces, allowing up to eight RPMs to be installed in the same panel. The processors with integral Module Interfaces must be installed in a HWI-PNL-8-CE Remote Power Panel.

## **MANUAL OVERRIDE CAPABILITIES**

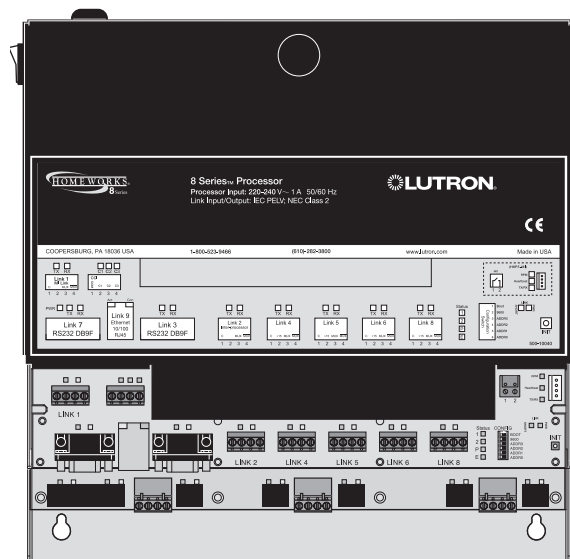
A manual override input is provided on each Module Interface, allowing a preset lighting scene to be activated from switches installed anywhere in the home.

## **CONNECTION TO PROCESSOR**

Each HomeWorks 8 series processor has one communication link (Link 1) dedicated to the control of up to 16 MIs. This connection must be daisy-chained and requires two pair [one pair 1.0 mm<sup>2</sup> (18 AWG), one pair 1.0 to 0.5 mm<sup>2</sup> (18-22 AWG) twisted shielded] Class 2/PELV wire. Lutron® wire model GRX-CBL-346S-500 may be used.



**View of  
stand-alone Module Interface  
(HWI-MI-230)**



**Processor with a module interface included**

# Module Interface

<b>Specifications apply to HWI-MI-230 stand-alone Module Interfaces and to Module Interfaces integral to HomeWorks® 8 series processors</b>	
Model	HWI-MI-230: stand-alone Module Interface. HWI-PM-230, H8P5-MI-CE, H8P5-MI-H48-CE: 8 series processor with integral Module Interface.
Input voltage	When integral to a processor, the MI is powered by 15 V <sub>DC</sub> provided by terminals 1 and 2 on the processor communications link connector. When a stand-alone MI is used, it is powered by a separate line-voltage feed (220-240 V <sub>AC</sub> 50/60 Hz) at the DIN rail terminal blocks and should not have terminal 2 connected on the processor communications link connector.
Regulatory approvals	CE, C-TICK
Environment	Ambient temperature: 0 °C to 40 °C (32 °F to 104 °F) Ambient humidity: 0-90% humidity, non-condensing. Indoor use only.
Cooling method	Passive cooling.
Low-voltage wire type	Two pair [one pair 1.0 mm <sup>2</sup> (18 AWG), one pair 1.0 to 0.5 mm <sup>2</sup> (18-22 AWG) twisted shielded] Class 2/PELV wire. Lutron® wire model GRX-CBL-346S-500 may be used.
Low-voltage wiring configuration	Maximum wire length of 305 m (1,000 feet). Must be wired in a daisy-chain configuration. Link Terminator (LT-1) is required if total cable length exceeds 15 m (50 feet).
Low-voltage connection	One 4-pin removable terminal block. Each of the four terminals will accept up to two 1.0 mm <sup>2</sup> (18 AWG) wires.
Addressing	Rotary switch. Counts as 1 of 16 MI addresses on an MI link.
Diagnostics	Three LEDs for troubleshooting communications with the processor and the RPMs.
ESD protection	Meets or exceeds the IEC 61000-4-2 standard.
Surge protection	Meets or exceeds ANSI/IEEE standard c62.41.
Miswire Protection	All terminal block inputs are over-voltage and miswire protected against wire reversals and shorts.
Fail-safe operation	The manual override scene is activated for all RPMs connected to the MI by closing a switch that is wired between the two manual override terminals. The switch (or relay) contacts must be rated for switching 50 milliamps at 30 V <sub>DC</sub> . A single switch can be used for multiple MIs wired in parallel, but proper polarity must be maintained across all units. In this configuration, the switch must be rated for the sum of the current for all of the MIs connected (e.g., six MIs wired to a single manual override switch requires a switch rated for 300 mA at 30 V <sub>DC</sub> ).

# Module Interface

**Specifications apply to HWI-MI-230 stand-alone Module Interfaces and to Module Interfaces integral to HomeWorks® 8 series processors**

Mounting dimensions	See figure 1, page 6.15.
Mounting	See figures 2, 3 and 4 on page 6.15. An integral MI is mounted within the processor. A stand-alone MI mounts in the lower right-hand corner of a panel enclosure (HWI-PNL-8-CE, HWI-PNL-5_CE, PBK8-40-13-CE and PBK8-40-13-10-CE).
Shipping weight	1.8 kg (4.0 pounds)
Output	Compatible with HW-RPM-4U dimming module, HW-RPM-4E ELV module, HW-RPM-4M motor module, HW-RPM-4R power relay module, and HW-RPM-4A adaptive dimming module.

# Module Interface

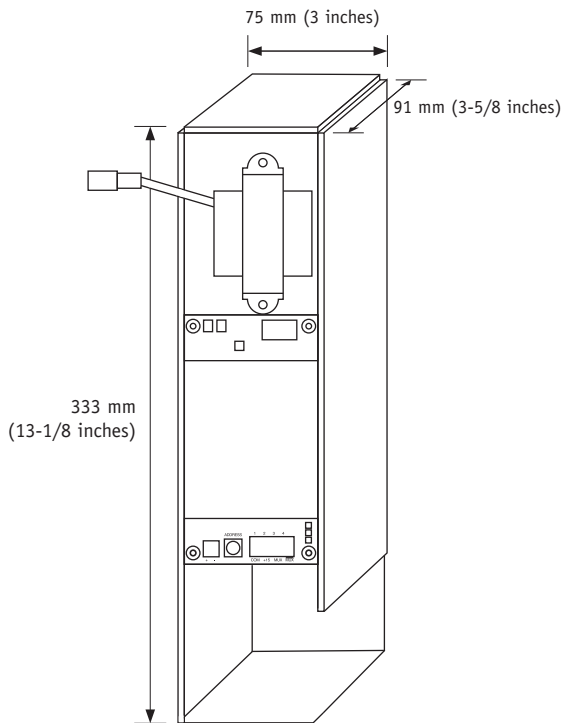
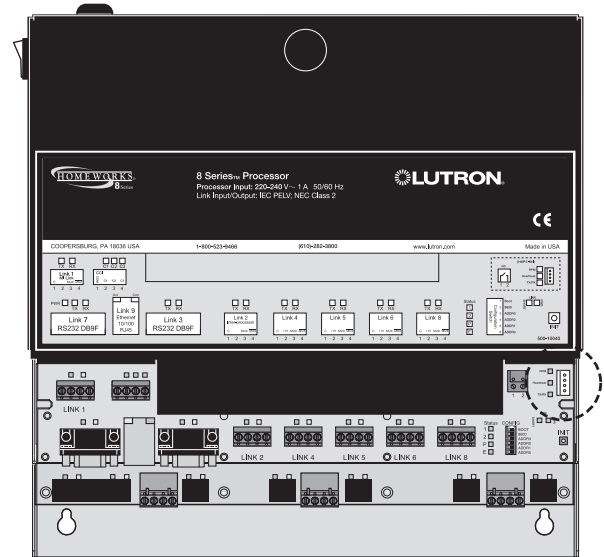


Figure 1 – HWI-MI-230 dimensions



Processor with a module interface included

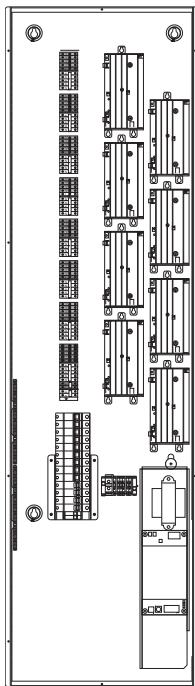


Figure 3 – HWI-MI-230 mounted in an PBK-40-13-CE enclosure

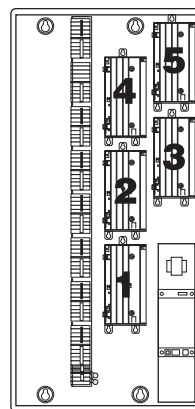


Figure 4 - HWI-MI-230 mounted in an HWI-PNL-5-CE enclosure

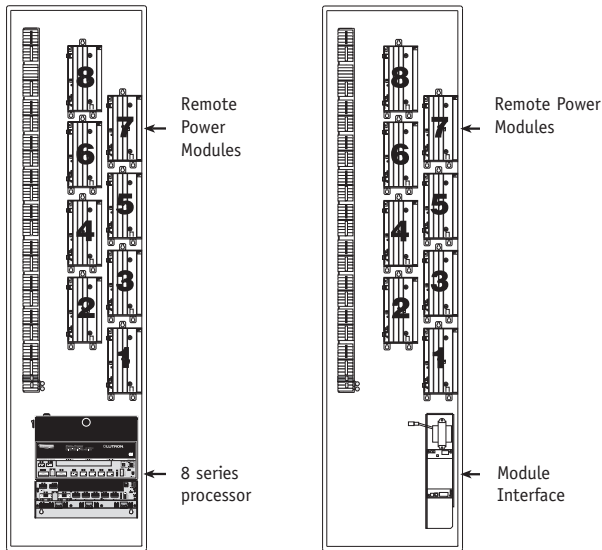
# Remote Power Panels (without breakers)

Remote Power Panels are available in two different sizes. The number of Remote Power Panels and the types of components within them may be specified to fit the size, lighting plan, and design of a home.

Remote Power Panels may contain HomeWorks® 8 series processors, Remote Power Modules, or Module Interfaces. Shown below are a few of the possible configurations.

## EIGHT-MODULE REMOTE POWER PANEL (MODEL HWI-PNL-8-CE)

Accommodates one of the following combinations of components:

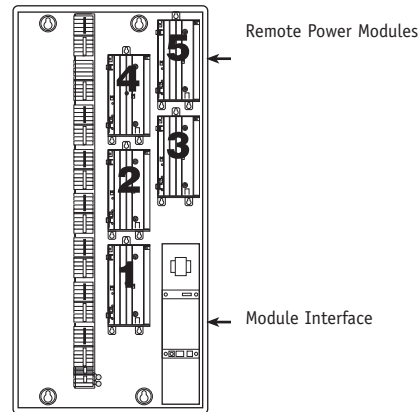


- Processor (1)
- Remote Power Modules (8 maximum)

- Module Interface (1)
- Remote Power Modules (8 maximum)

## FIVE-MODULE REMOTE POWER PANEL (MODEL HWI-PNL-5-CE)

Accommodates the following combination of components:



- Module Interface (1)
- Remote Power Modules (5 maximum)

**Note:** HWI-PNL-5 *cannot* include a HomeWorks processor



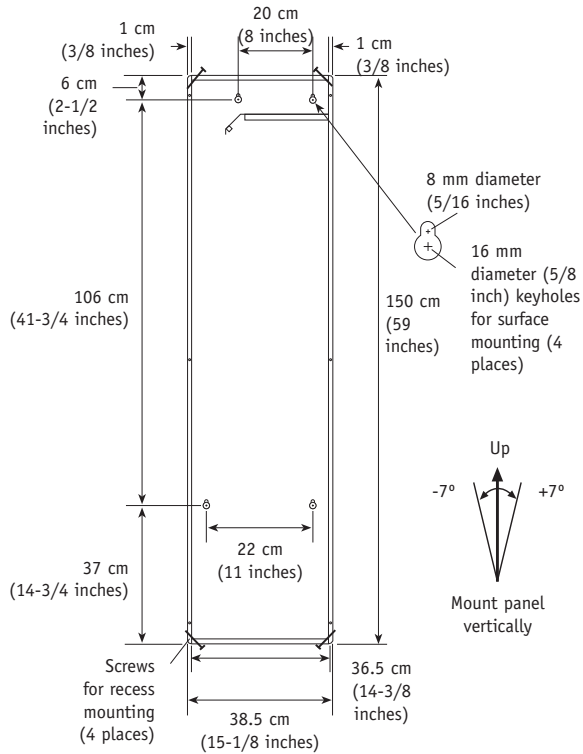
# Remote Power Panels (without breakers)

Model	HWI-PNL-8-CE: eight module Remote Power Panel.
Capacity	Eight RPMs (HW-RPM-4U, HW-RPM-4E, HW-RPM-4M, HW-RPM-4R, and HW-RPM-4A) and one Module Interface or 8 series processor.
Regulatory approvals	CE, C-TICK
Environment	Ambient temperature: 0 °C to 40 °C (32 °F to 104 °F) Ambient humidity: 0-90% humidity, non-condensing. Indoor use only.
Cooling method	Passive cooling. Mount in a place where the vented cover will not be blocked.
Heat generated fully loaded	656 BTUs per hour maximum.
Line-voltage connections	Use copper wire only, supply conductors 60/75 °C. DIN rail-mounted terminal blocks provided for line-voltage Remote Power Module (RPM) wiring and processor/MI power. Terminal blocks should be tightened to 0.40-0.57 n·m (3.5 to 5.0 inch-pounds). <i>See page 6.19.</i>
DIN rail terminal blocks	Terminal blocks will accept one 1.0 to 2.5 mm <sup>2</sup> (18-10 AWG) wire or two 1.0 to 1.5 mm <sup>2</sup> (18-16 AWG) wires. Terminal blocks should be tightened to 0.40-0.57 n·m (3.5-5.0 inch-pounds). All terminal blocks are shipped with bypass jumpers installed. After verifying that each circuit is wired correctly, remove the bypass jumpers for system operation.
Ground bar terminals	24 ground termination points.
Miswire protection	All terminal blocks are shipped with bypass jumpers installed.
Mounting	Panel must be mounted within 7 degrees from vertical. Allow at least 30 cm (12 inches) air space at top and bottom and a minimum of 30 cm (12 inches) clearance in front of panel. Remote Power Panels will hum slightly and internal relays will click while in use. Locate where such noise is acceptable. Locate the panel so that line-voltage wiring will be at least 1.8 m (6 feet) from audio or electronic equipment and its wiring.
Dimensions	36.5 cm (14-3/8 inches) x 150 cm (59 inches) x 11.0 cm (4.34 inches)
Construction	Enclosure: 16-gauge galvanized sheet metal (unpainted). Cover: Painted (black) metal cover with ventilation holes.
Shipping weight	11.4 kg (25.0 pounds)

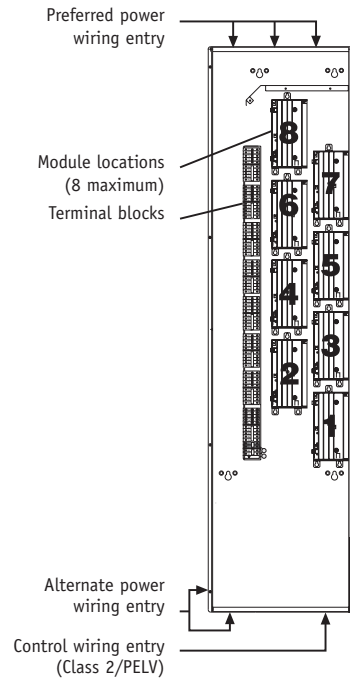
# Remote Power Panels (without breakers)

Model	HWI-PNL-5-CE: five module Remote Power Panel.
Capacity	Five RPMs (HW-RPM-4U, HW-RPM-4E, HW-RPM-4M, HW-RPM-4R, and HW-RPM-4A) and one Module Interface.
Regulatory approvals	CE, C-TICK
Environment	Ambient temperature: 0 °C to 40 °C (32 °F to 104 °F) Ambient humidity: 0-90% humidity, non-condensing. Indoor use only.
Cooling method	Passive cooling. Mount in a place where the vented cover will not be blocked.
Heat generated fully loaded	420 BTUs per hour maximum.
Line-voltage connections	Use copper wire only, supply conductors 60/75 °C. DIN rail-mounted terminal blocks provided for line-voltage Remote Power Module (RPM) wiring and processor/MI power. Terminal blocks should be tightened to 0.40-0.57 n·m (3.5-5.0 inch-pounds). <i>See page 6.19.</i>
DIN rail terminal blocks	Terminal blocks will accept one 1.0 to 2.5 mm <sup>2</sup> (18-10 AWG) wire or two 1.0 to 1.5 mm <sup>2</sup> (18-16 AWG) wires. Terminal blocks should be tightened to 0.40-0.57 n·m (3.5-5.0 inch-pounds). All terminal blocks are shipped with bypass jumpers installed. After verifying that each circuit is wired correctly, remove the bypass jumpers for system operation.
Ground bar terminals	24 ground termination points.
Miswire protection	All terminal blocks are shipped with bypass jumpers installed.
Mounting	Panel must be mounted within 7 degrees from vertical. Allow at least 30 cm (12 inches) air space at top and bottom and a minimum of 30 cm (12 inches) clearance in front of panel. Remote Power Panels will hum slightly and internal relays will click while in use. Locate where such noise is acceptable. Locate the panel so that line-voltage wiring will be at least 1.8 m (6 feet) from audio or electronic equipment and its wiring.
Dimensions	36.5 cm (14-3/8 inches) x 81 cm (32 inches) x 11.0 cm (4.34 inches)
Construction	Enclosure: 16-gauge galvanized sheet metal (unpainted). Cover: Painted (black) metal cover with ventilation holes.
Shipping weight	8.6 kg (18.0 pounds)

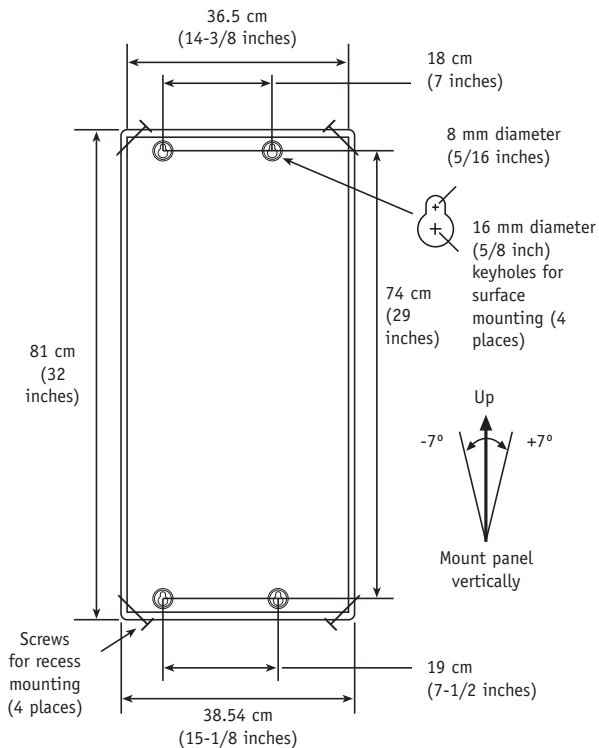
# Remote Power Panels (without breakers) Installation



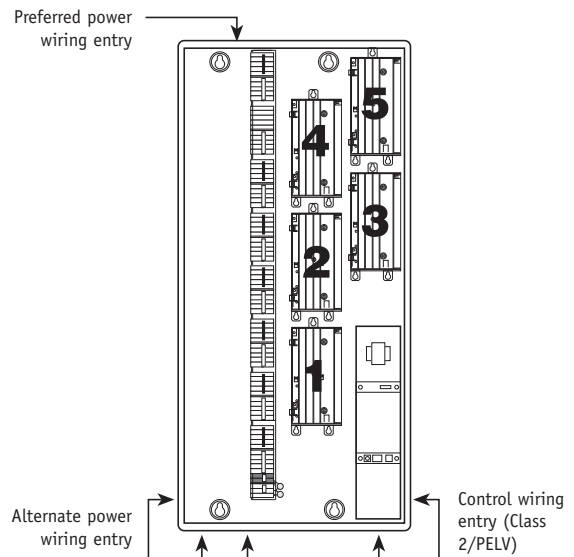
**Figure 1 – HW-PNL-8-CE panel dimensions**  
Panel is 11.0 cm (4.34 inches) deep.



**Figure 2 – wiring entry**



**Figure 1 – HW-PNL-5-CE panel dimensions**  
Panel is 11.0 cm (4.34 inches) deep.



**Figure 2 – wiring entry**

# Remote Power Panels (with breakers)

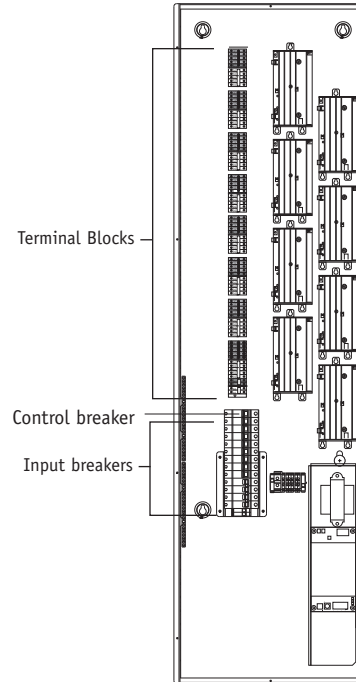
Remote Power Panels with breakers include input breakers and optional 10 A output breakers. Remote Power Panels with breakers require only one 3-phase feed from the main distribution panel, reducing the number of wiring connections required.

Standard Remote Power Panels with breakers are available that hold up to 8 RPM modules. Custom Remote Power Panels with breakers are available that hold up to 5 RPM modules.

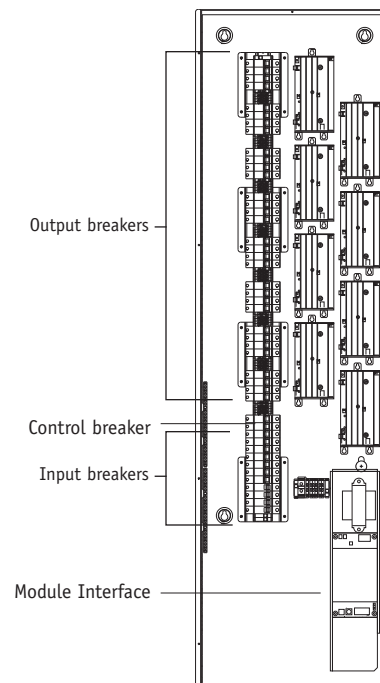
PBK5-40-13-10-CGP1243 with input and output breakers.

PBK5-40-13-CE-CGP1244 with input breakers only.

Contact Lutron® for more information about PBK5 panels.



*Remote Power Panel with input breakers  
(PBK8-40-13-CE)*

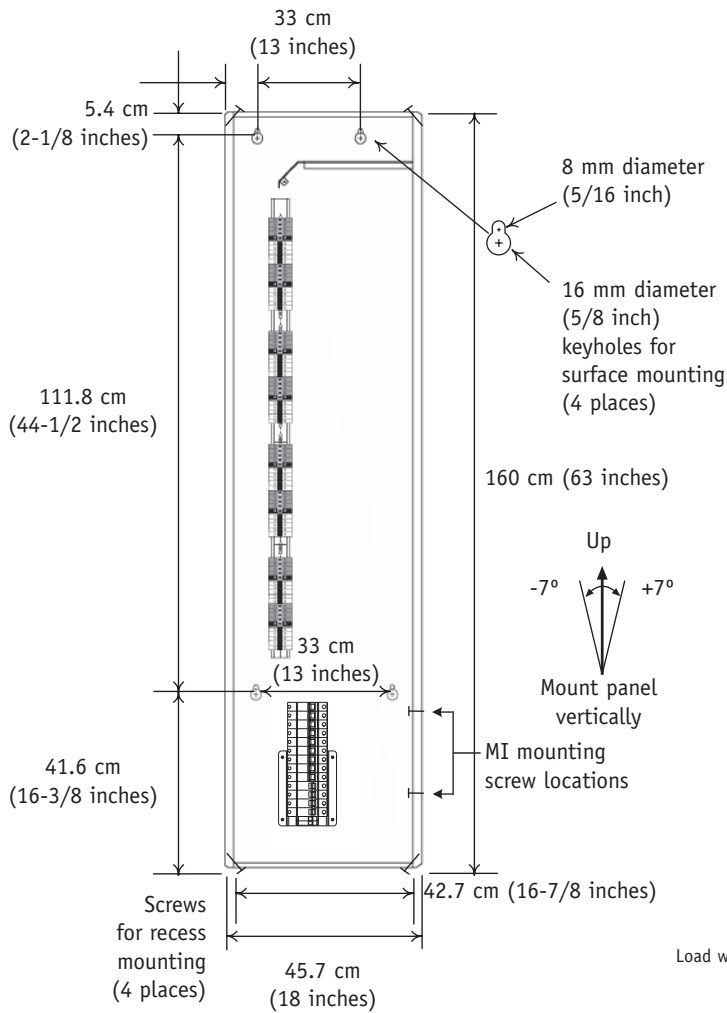


*Remote Power Panel with input and output breakers  
(PBK8-40-13-10-CE)*

# Remote Power Panels (with breakers)

Model	PBK8-40-13-CE, PBK8-40-13-10-CE
Capacity	Eight RPMs (HW-RPM-4U and HW-RPM-4A) and one Module Interface or 8 series processor.
Regulatory approvals	CE, C-TICK
Environment	Ambient temperature: 0 °C to 40 °C (32 °F to 104 °F) Ambient humidity: 0-90% humidity, non-condensing. Indoor use only.
Cooling method	Passive cooling. Mount in a place where the vented cover will not be blocked.
Heat generated fully loaded	656 BTUs per hour maximum.
Line-voltage connections	Use copper wire only, supply conductors 60/75 °C. DIN rail-mounted terminal blocks provided for line-voltage Remote Power Module (RPM) wiring and processor/MI power. Terminal blocks should be tightened to 0.40-0.57 n·m (3.5-5.0 inch-pounds).
DIN rail terminal blocks	Terminal blocks will accept one 1.0 to 2.5 mm <sup>2</sup> (18-10 AWG) wire or two 1.0 to 1.5 mm <sup>2</sup> (18-16 AWG) wires. Terminal blocks should be tightened to 0.40-0.57 n·m (3.5-5.0 inch-pounds). All terminal blocks are shipped with bypass jumpers installed. After verifying that each circuit is wired correctly, remove the bypass jumpers for system operation.
Ground bar terminals	40 ground termination points.
Miswire protection	All terminal blocks are shipped with bypass jumpers installed.
Mounting	Panel must be mounted vertically (+/- 7 degrees from vertical). Allow at least 30 cm (12 inches) air space at top and bottom and a minimum of 30 cm (12 inches) clearance in front of panel. Remote Power Panels will hum slightly and internal relays will click while in use. Locate where such noise is acceptable. Locate the panel so that line-voltage wiring will be at least 1.8 m (6 feet) from audio or electronic equipment and its wiring.
Dimensions	42.7 cm (16-7/8 inches) x 160 cm (63 inches) x 10.2 cm (4 inches)
Construction	Enclosure: 16-gauge galvanized sheet metal (unpainted). Cover: painted (black) metal cover with ventilation holes.
Shipping weight	30.9 kg (68.0 pounds)

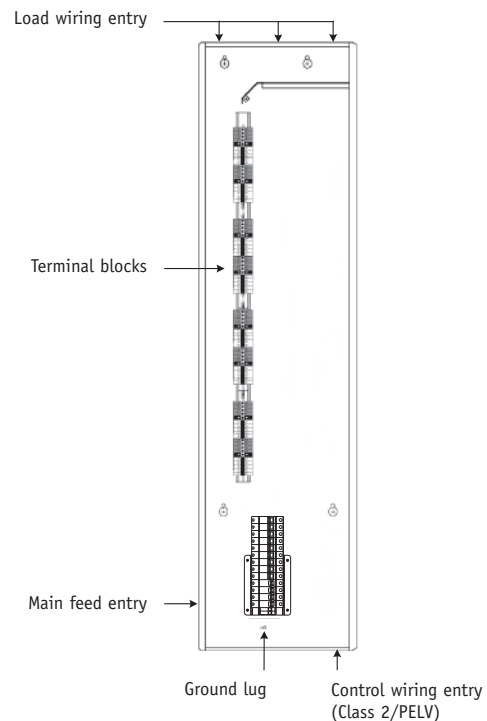
# Remote Power Panels (with breakers) Installation



**Figure 21 – panel dimensions**  
Panel is 10.2 cm (4 inches) deep.

**Notes:**

1. PBK8-40-13-CE has one 3-phase, 4-pole, 40 Amp main input breaker; eight (8) 13 Amp branch circuit input breakers; and one (1) 13 Amp input control breaker.
2. PBK8-40-13-10-CE also has thirty two (32) 10 Amp output breakers.



**Figure 22 – wiring entry**



# Power Boosters and Interfaces

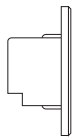
# Power Boosters and Interfaces

Power Boosters and interfaces are required in some applications to increase the load capacity of a component or to interface with a specific type of load. Power Boosters and interfaces can be used with HomeWorks®, Maestro switches, GRAFIK Eye® control units, GRAFIK Integrale® control units, Wallbox Power Modules and Remote Power Modules. Power Boosters and interfaces are typically installed in electrical closets or other hidden locations.



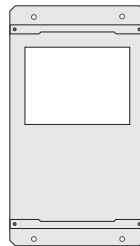
## FLUORESCENT DIMMING BALLAST INTERFACE MODEL NGRX-FDBI-AU (NON-CE)

Fluorescent Dimming Ballast Interfaces are used to dim a single zone of fluorescent lighting with Lutron Hi-lume® dimming ballasts.



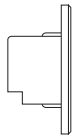
## POWER BOOSTER MODELS NGRX-PB-CE AND NGRX-PB-AU (NON-CE)

Power Boosters increase the capacity of a single zone of lighting. Compatible load types are incandescent, magnetic low-voltage, electronic low-voltage (requires Lutron® low-voltage transformers), and neon/cold cathode.



## 0 - 10 V INTERFACE MODEL GRX-TVI

0-10 V interfaces are used to dim a single zone of fluorescent lighting with dimming ballasts that require a 0-10 V signal for control. The TVI can also be used to switch 10 Amps of non-dim electronic ballasts or 1/2 HP motors.



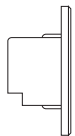
## ELECTRONIC LOW-VOLTAGE INTERFACE MODELS NGRX-ELVI-CE AND NGRX-ELVI-AU (NON-CE)

Electronic Low-voltage Interfaces are used to dim a single zone of electronic low-voltage lighting. The ELVI is not necessary for use with GRAFIK Integrale or if Lutron low-voltage transformers are used (see section 12).



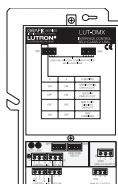
## TEN VOLT MODULES (SEE TVM KIT)

TVM modules can be located in HomeWorks Remote Power Panels. The TVM module is used in combination with the HW-RPM-4U module to control fluorescent dimming ballasts that use either a 0-10 V control signal, the DSI control signal, a PWM control signal or the DALI control signal (intensity broadcast only).



## SYNTHETIC MINIMUM LOAD INTERFACE LUT-LBX-CE-WH

Provides the required minimum load to a dimmer when the actual load is less than the minimum.



## DMX-512 INTERFACE LUT-DMX

LUT-DMX connects to the MI Link (1) of an 8-series processor. The interface converts zone dimming-levels to DMX-512 protocol for up to 256 zones on a single HomeWorks processor.



# Power Boosters and Interfaces

Model	NGRX-PB-AU, NGRX-PB-CE: Power Booster. NGRX-ELVI-AU, NGRX-ELVI-CE: Electronic Low-voltage Interface. NGRX-FDBI-AU: Fluorescent Dimming Ballast Interface.
Input voltage	220-240 V $\sim$ 50/60 Hz
Regulatory approvals	CE, C-Tick (CE models)
Load types	NGRX-PB-: incandescent, magnetic low-voltage, neon/cold-cathode, electronic low-voltage (requires Lutron® low-voltage transformer). NGRX-ELVI-: electronic low-voltage NGRX-GRX-FDBI-: <i>Lutron</i> Hi-lume® fluorescent dimming ballasts.
Maximum load	NGRX-PB-AU: 10 A NGRX-PB-CE: 8 A surface mounted, 5.2 A flush mounted NGRX-ELVI-: 5 A (CE and non-CE models) NGRX-FDBI-AU: 10 A
Minimum load	25 W/VA
Environment	Ambient temperature: 0 °C to 40 °C (32 °F to 104 °F) Ambient humidity: 0-90% humidity, non-condensing. Indoor use only.
Cooling method	Passive cooling.
Heat generated fully loaded	82 BTUs per hour per output.
Line-voltage connections	See figures 2-6, pages 7.4 to 7.6.
ESD protection	Meets or exceeds the IEC 61000-4-2 standard.
Surge protection	Meets or exceeds ANSI/IEEE standard c62.41.
Mounting	2-gang US wallbox, 70 mm (2-3/4 inches) deep minimum, 89 mm (3-1/2 inches) deep recommended. (2) <i>Lutron</i> P/N 241218 may be used.
Terminals	Each terminal will accept two 2.5 mm <sup>2</sup> (12 AWG) wires.
Shipping weight	0.5 kg (1.0 pound)

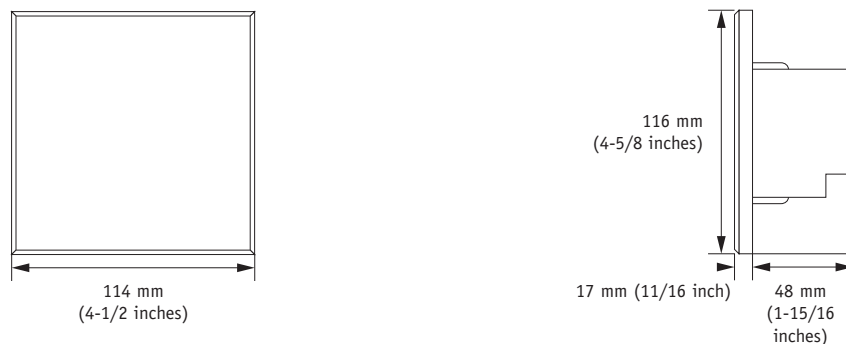


Figure 1 – dimensions

# Power Boosters – Wiring Diagrams

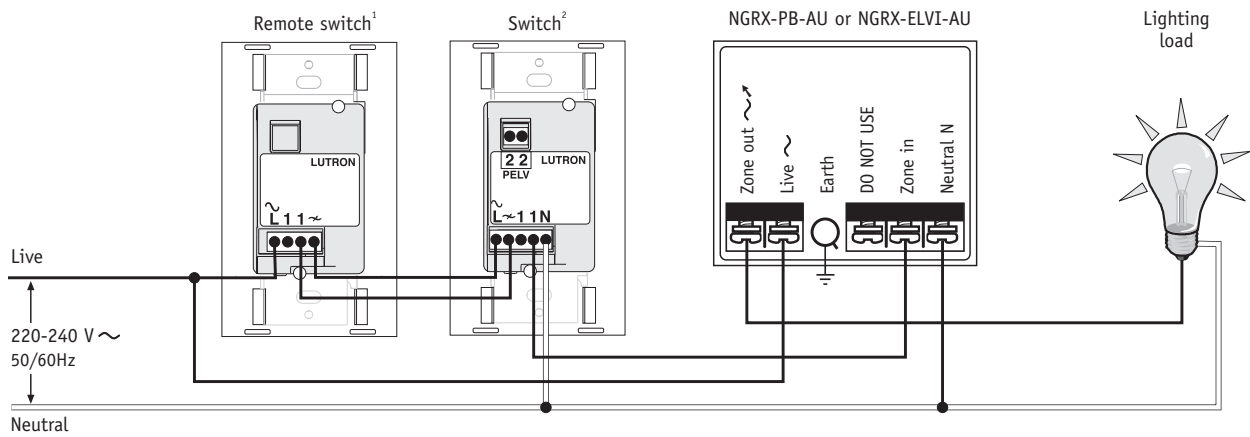


Figure 2 – NGRX-PB-AU and NGRX-ELVI-AU with HomeWorks® Maestro®.

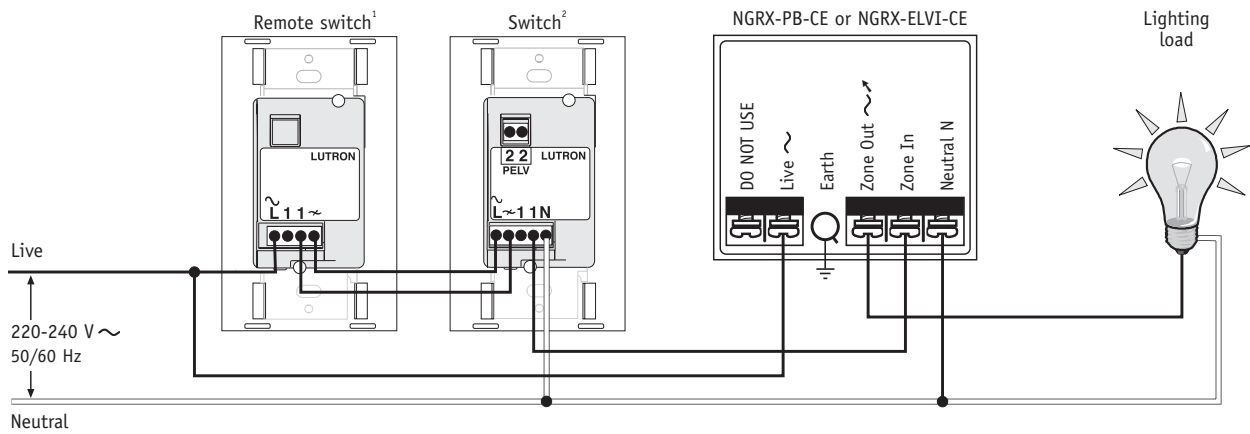


Figure 3 – NGRX-PB-CE and NGRX-ELVI-CE with HomeWorks Maestro

<sup>1</sup> Up to nine HomeWorks Maestro remote switches may be connected to a HomeWorks Maestro switch. Total wire length between all devices cannot exceed 50 m (165 feet).

<sup>2</sup> Switches must be connected on the interface side of a multi-location installation.

# Power Boosters – Wiring Diagrams

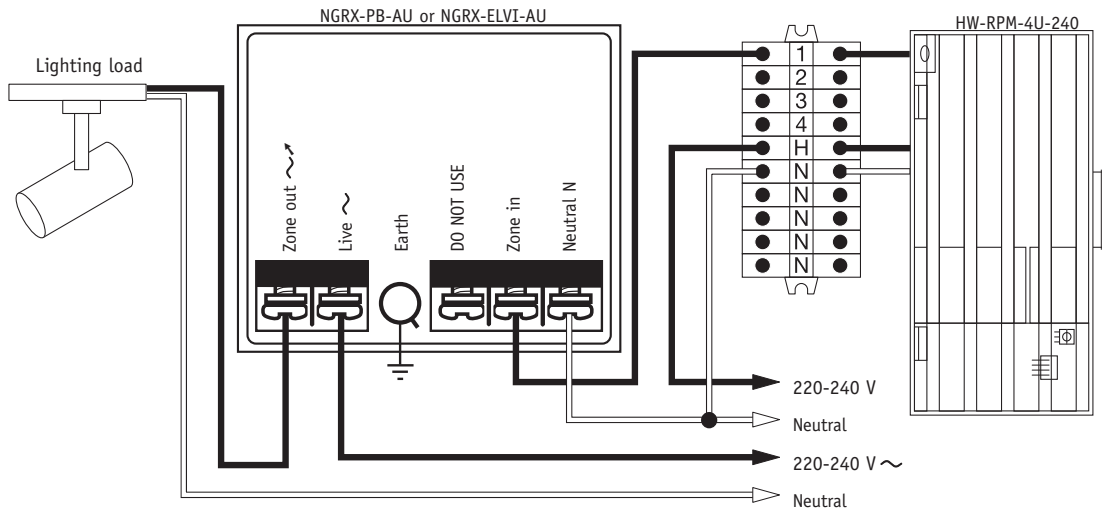


Figure 4 – NGRX-PB-AU or NGRX-ELVI-AU with Remote Power Modules

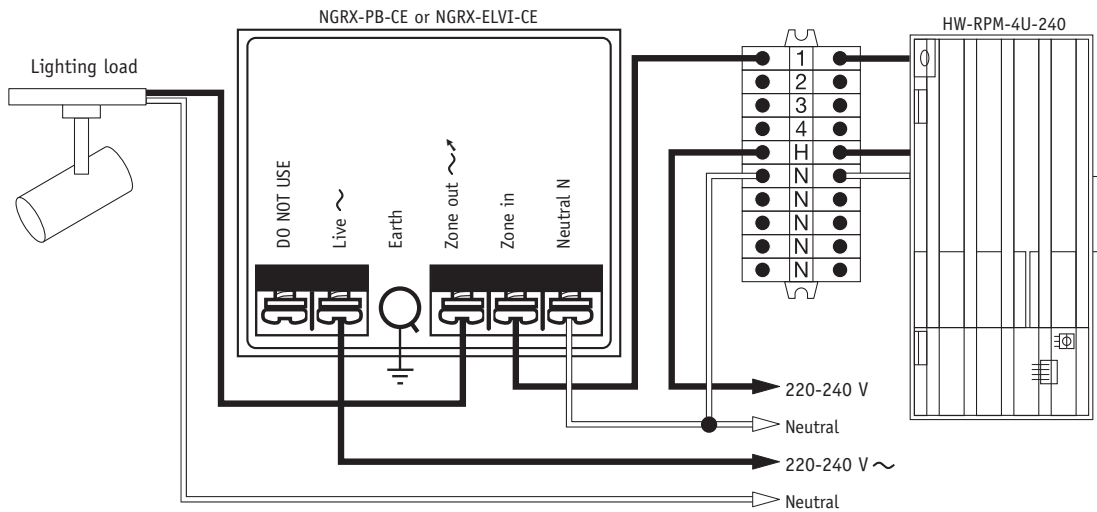


Figure 5 – NGRX-PB-CE or NGRX-ELVI-CE with Remote Power Modules

# FDBI – Wiring Diagrams

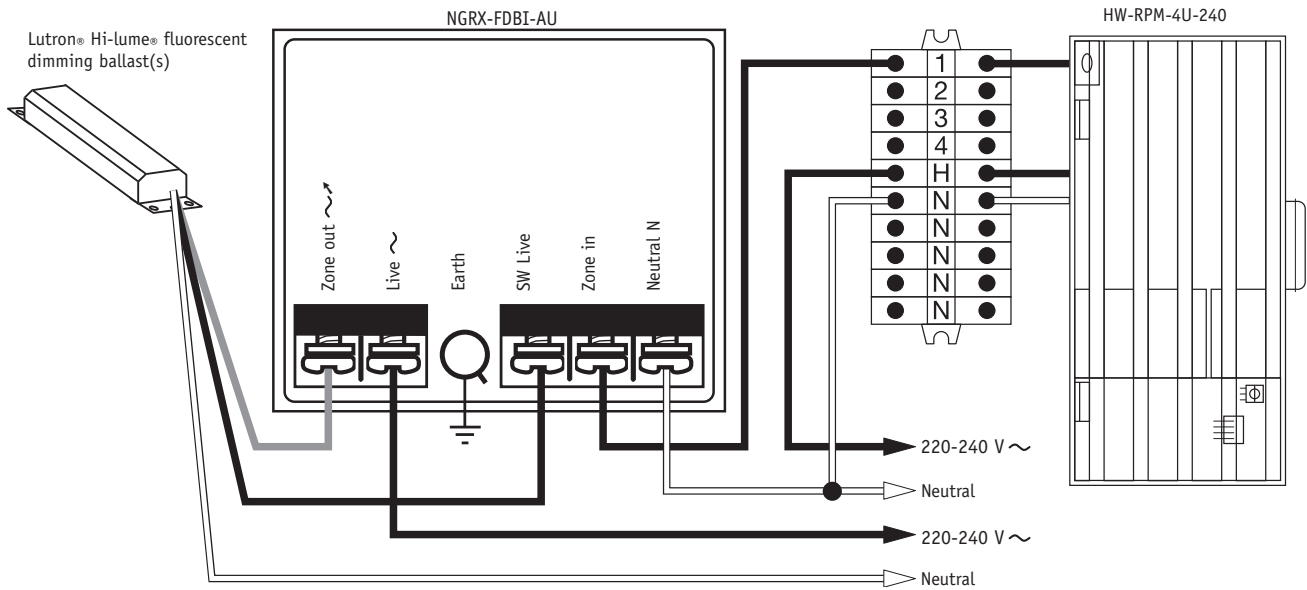


Figure 6 – NGRX-FDBI-AU installation with Remote Power Modules

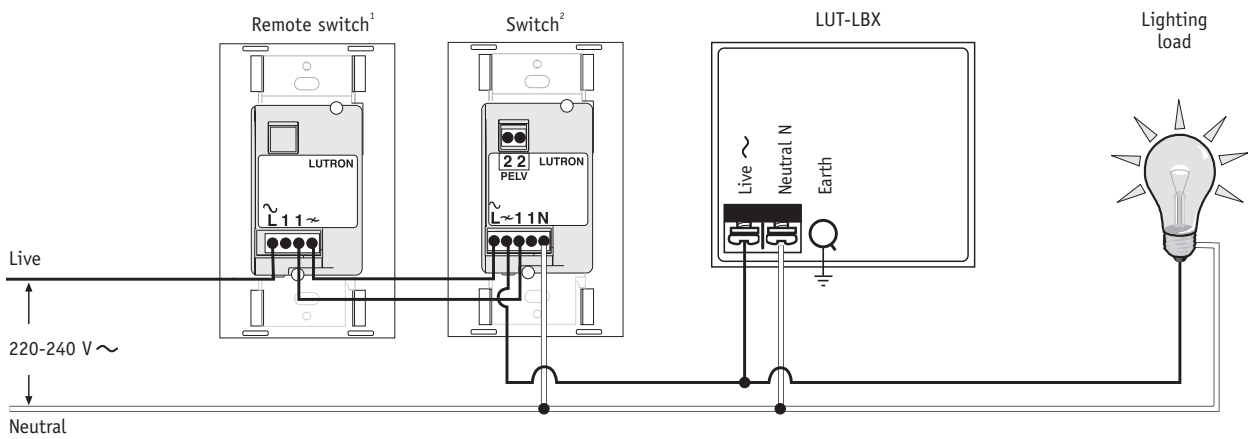


Figure 7 – LUT-LBX

# 0-10 V Interface

Model	GRX-TVI
Input voltage	100-277 V ~ 50/60 Hz
Regulatory approvals	CE, C-Tick, UL, CSA, NOM
Load types	Fluorescent dimming ballast which accept 0-10V control signal.
Maximum load	10 A or 1/2 HP
Minimum load	25 W/VA
Environment	Ambient temperature: 0 °C to 40 °C (32 °F to 104 °F) Ambient humidity: 0-90% humidity, non-condensing. Indoor use only.
Cooling method	Passive cooling.
0-10V output rating	10 µA-300 mA, sinks current only.
Line-voltage connections	See figure 2, page 7.8.
ESD protection	Meets or exceeds the IEC 61000-4-2 standard.
Surge protection	Meets or exceeds ANSI/IEEE standard c62.41.
Mounting	Wall mounted.
Terminals	Each terminal will accept two 2.5 mm <sup>2</sup> (12 AWG) wires.
Shipping weight	2.0 kg (4.5 pounds)

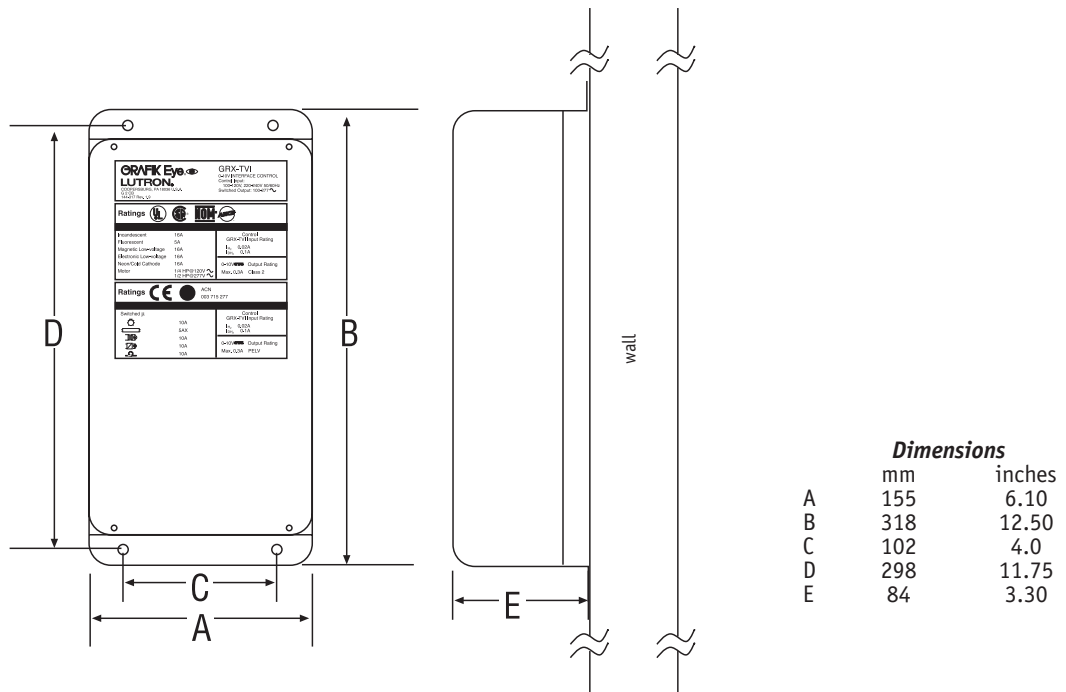


Figure 1 - dimensions

# 0-10 V Interface – Wiring Diagrams

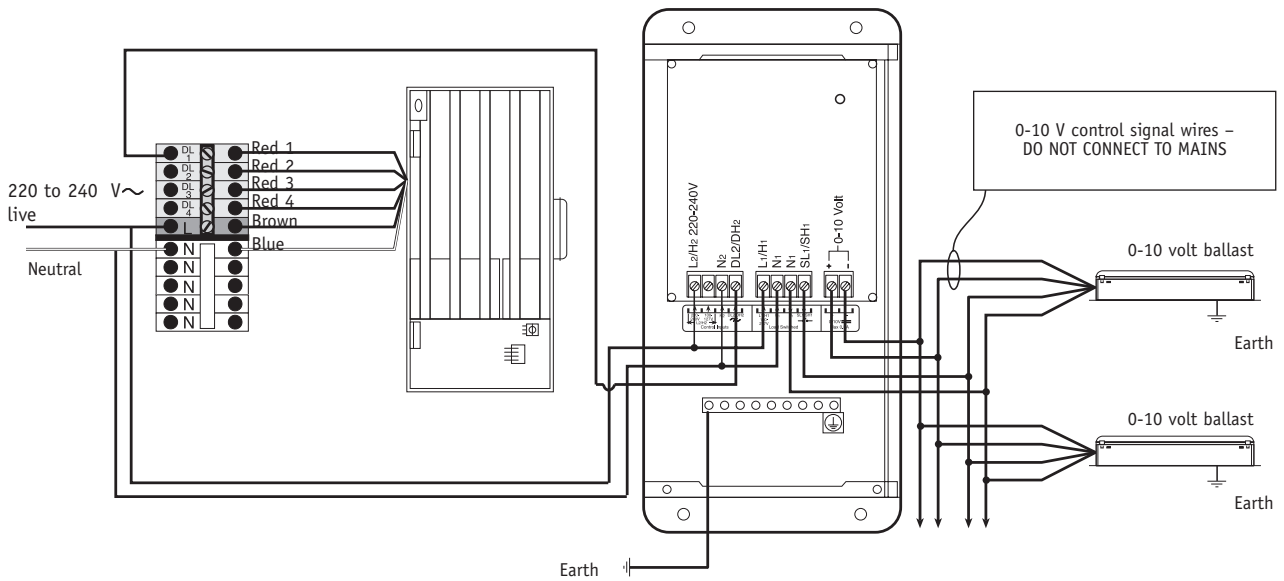


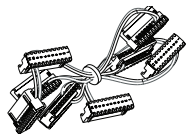
Figure 2 - GRX-TVI with a Remote Power Module

# TVM Dimming Kit

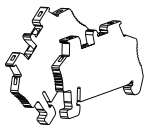
## ***HW-TVMKIT-230***

The TVM Kit is a package that contains the parts required to install TVMs (not included). Load types such as 0-10 V, DALI broadcast, PWM, and Tridonic DSI™ can be controlled by the TVM, with the addition of a module interface or a circuit selector. Customers can mount the TVM Kit in their own enclosure or add it to an existing Lutron® enclosure. A TVM Kit will allow the addition of 1 to 12 TVMs, which can control 1 to 24 circuits of the above load types.

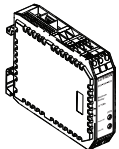
## ***KIT CONTENTS***



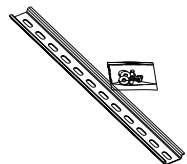
Addressing Harness



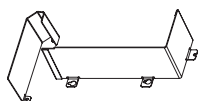
DIN Rail End Stops



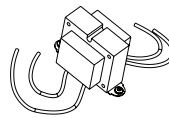
GRX-TVM-ISO2  
24 V ~ 50/60 Hz 750 mA



DIN Rail and Mounting Hardware



Low-voltage Barrier and Mounting Hardware



Power Supply Transformer

HW-TVMKIT-230  
Input: 220–240 V ~ 50 Hz 40 W  
Output: 24 V ~ 1.6 A Class 2/IEC PELV

## ***Addressing Harness***

This harness connects the ISO to the TVM units. The connector labeled “TVM1” plugs into the first TVM will automatically configure it to control circuits 1 and 2. Each additional connection accounts for 2 circuits for up to 24 circuits.

## ***Din Rail***

The package includes a 30.5 cm DIN Rail and two end stops to allow you to fasten the ISO2 and TVM2 modules to the panel.

## ***ISO***

The ISO provides isolated power to up to 12 TVM2 units. Only one ISO is needed in a TVM dimming kit. Maximum output current on ISO is 750 mA.

## ***Low-voltage Transformer***

A 24 V ~ transformer provides power to the ISO.

## ***ORDERING METHOD***

Order 1 TVM kit to install up to 12 TVMs. ISO in TVM kit supplies a maximum current of 750 mA. Verify total current draw of ballast control wiring as values may vary (See ballast/driver manufacturer specifications for more information.)

Note: TVMs are ordered separately. See page 7.13.

# TVM Dimming Kit

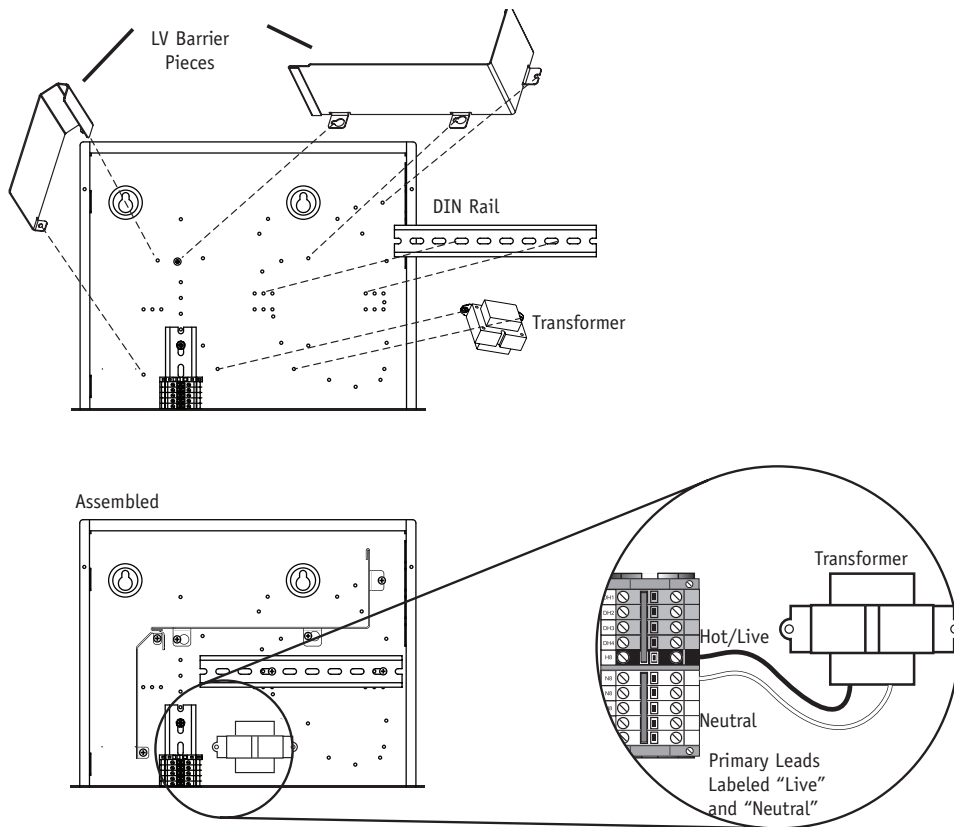


Figure 1 – Kit Installation

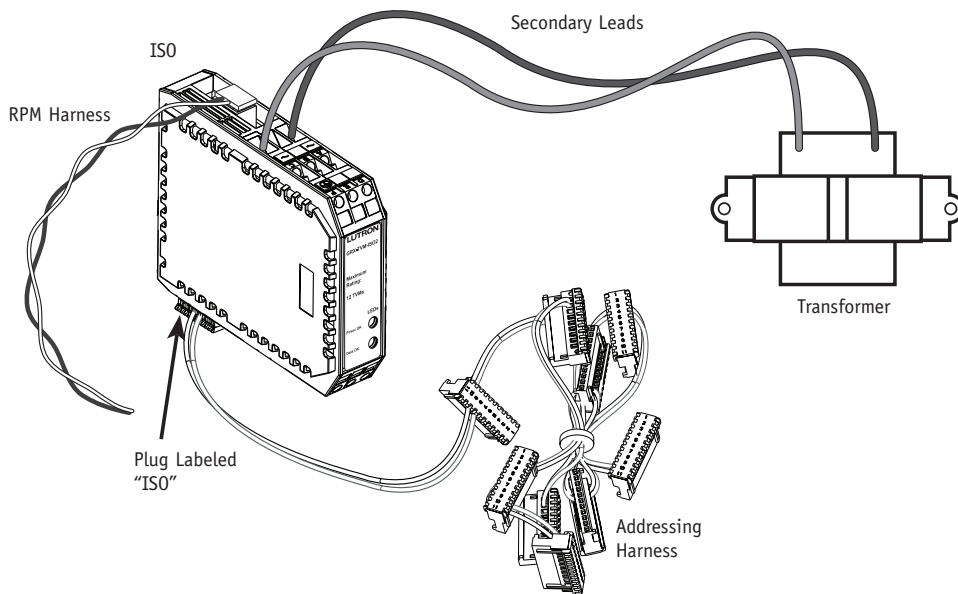
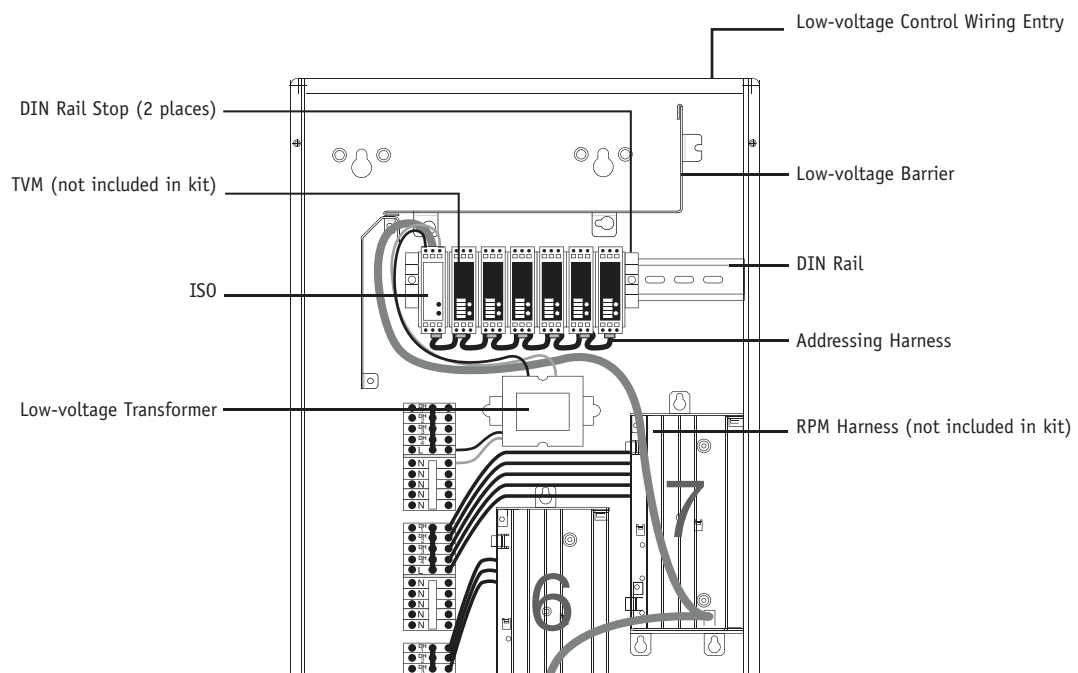


Figure 2 – ISO Wiring



# TVM Dimming Kit



**Figure 3 –  
Mounting the TVM kit**

When adding a TVM kit to a custom enclosure, be sure to include a circuit selector or module interface to control the TVMs.

The TVM kit occupies the space of the top RPM module in a remote power panel. Therefore, a PNL-5 panel with a TVM kit can only hold 4 RPM modules and a PNL-8 panel with a TVM kit can only hold 7 RPM modules.

# TVM Dimming Kit

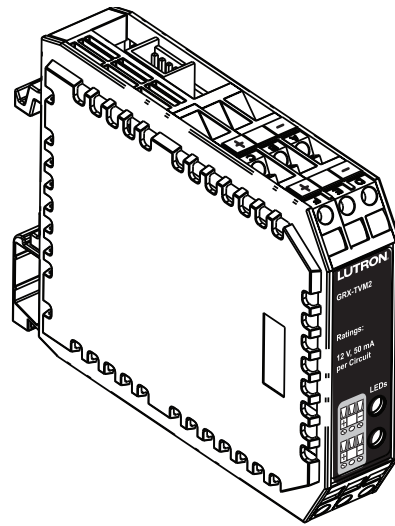
<b>TVM Dimming Kit</b>	
Model Numbers	HW-TVMKIT-230
Power Supply Input voltage	220-240 V ~ 50/60 Hz
ISO Input Voltage	24 V ~
ISO Maximum Current	750 mA
Load Types	0-10 V @ 50 mA sinking/sourcing. DALI broadcast, DSI, PWM
Regulatory Approvals	CE
Environment	Ambient operating temperature: 0 °C to 40 °C (32 °F to 104 °F) Ambient operating humidity: 0-90% humidity, non-condensing. Indoor use only.
Low-voltage Wiring	Addressing harness connects ISO to each TVM. Low-voltage MI or Circuit Selector harness connects the dimming kit panel interface.
Addressing	Addressed via addressing harness. Each connector represents an address from 1 to 12.
Diagnostics	2 LEDs for troubleshooting communications with Module Interface and power.
ESD Protection	Meets or exceeds IEC 61000-4-2 standard.
Surge Protection	Meets or exceeds ANSI/IEEE standard c62.41.
DIN Rail Length	30.5 cm
Shipping Weight	2.0 kg (44.1 pounds)

# Ten Volt Module

## GRX-TVM2

Ten Volt Modules (TVMs) are designed to be installed with a TVM Kit to dim various load types such as 0-10 V, DALI broadcast, PWM, and Tridonic DSI™. Each TVM has two outputs.

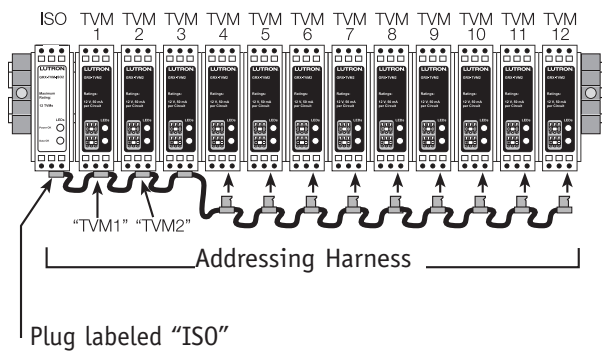
TVMs can work in conjunction with Remote Power Modules (RPM-4A or -4U) in the panel to switch the ballast/driver. The TVM has the ability to sink or source current up to 50 mA per output.



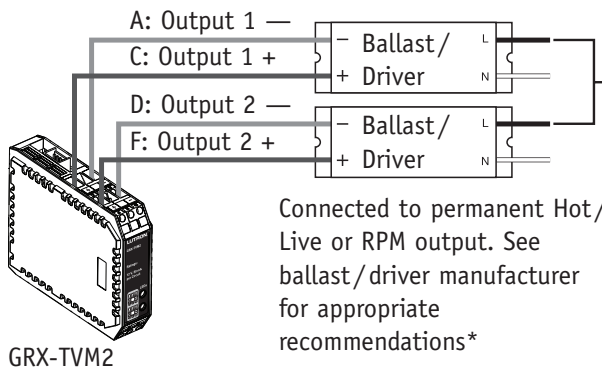
GRX-TVM2

## TVM INSTALLATION

1. Attach the addressing harness to the bottom of the corresponding TVM. The first TVM uses the connector labeled "TVM 1" (first connector after "ISO"). Repeat for additional TVM(s).
2. Snap the TVM unit(s) into the DIN rail. Snap an endstop into the DIN rail and slide left against the last TVM.



3. Connect low-voltage signal wires from ballast/driver circuits to the "+" and "-" terminals located on the top of the TVMs. Be sure to observe proper polarity. Terminals "A" and "C" are output 1 and terminals "D" and "F" are output 2.



TVM	TVM Output #	RPM #	RPM Output #
TVM 1	1	RPM 1	1
	2		2
TVM 2	1		3
	2		4
TVM 3	1	RPM 2	1
	2		2
TVM 4	1		3
	2		4
TVM 5	1	RPM 3	1
	2		2
TVM 6	1		3
	2		4
TVM 7	1	RPM 4	1
	2		2
TVM 8	1		3
	2		4
TVM 9	1	RPM 5	1
	2		2
TVM 10	1		3
	2		4
TVM 11	1	RPM 6	1
	2		2
TVM 12	1		3
	2		4

\* Some ballasts/drivers require a permanent Hot/Live connection while others must be switched off in conjunction with the TVM. Consult ballast/driver manufacturer instructions for details.

# LUT-DMX

## DMX 512-INTERFACE (MODEL # LUT-DMX)

The LUT-DMX is an interface that allows HomeWorks® to control DMX-512 load types. The LUT-DMX unit is connected on the 4-wire MI link (link 1) of a HomeWorks 8-series Processor. It will convert zone intensity information generated by the HomeWorks Processor and create a DMX-512 data stream.

### HOW IT WORKS

Each DMX-512 channel is mapped to a zone in the HomeWorks processor. Each processor can control a maximum of 256 zones. The amount of DMX-512 channels that can be used depends on the number of zones that are being used by other HomeWorks equipment including Rania®, Maestros®, RPMs, WPMs, GRAFIK Eye®, and Sivoia QED®.

For example: If there are 190 zones assigned to the processor from equipment including Rania, Maestros, RPMs, WPMs, GRAFIK Eye, and Sivoia QED then there would be 66 zones left that could be assigned as DMX-512 channels.

The number of channels required by a DMX device depends on the specific equipment. Some devices may only need 1 channel for intensity. A colour LED fixture may require 3 channels for red intensity, blue intensity and green intensity. Other devices may require more. You should review the documentation of the specific DMX equipment to understand how its DMX channels will be mapped.

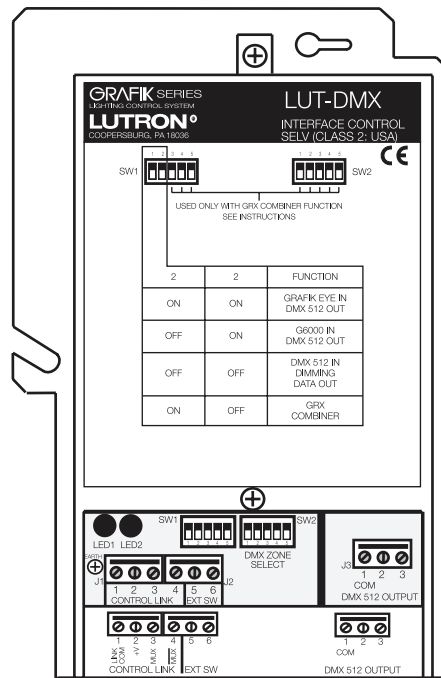


Figure 1 – LUT-DMX interface

# LUT-DMX

## DIMENSIONS

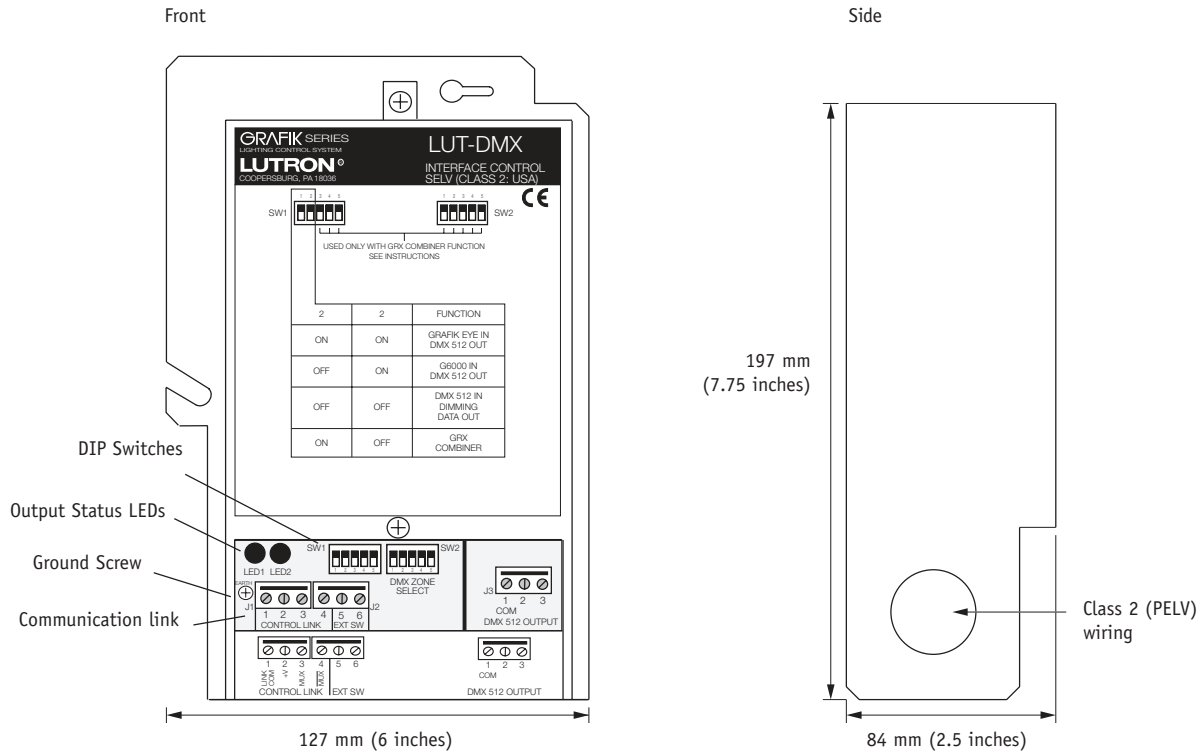


Figure 3 – LUT-DMX dimensions

## MOUNTING

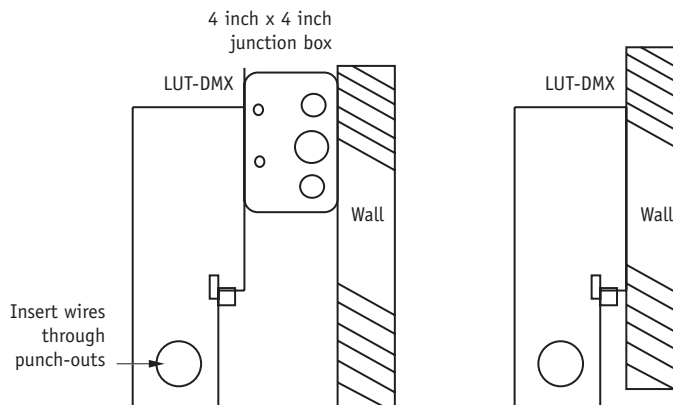
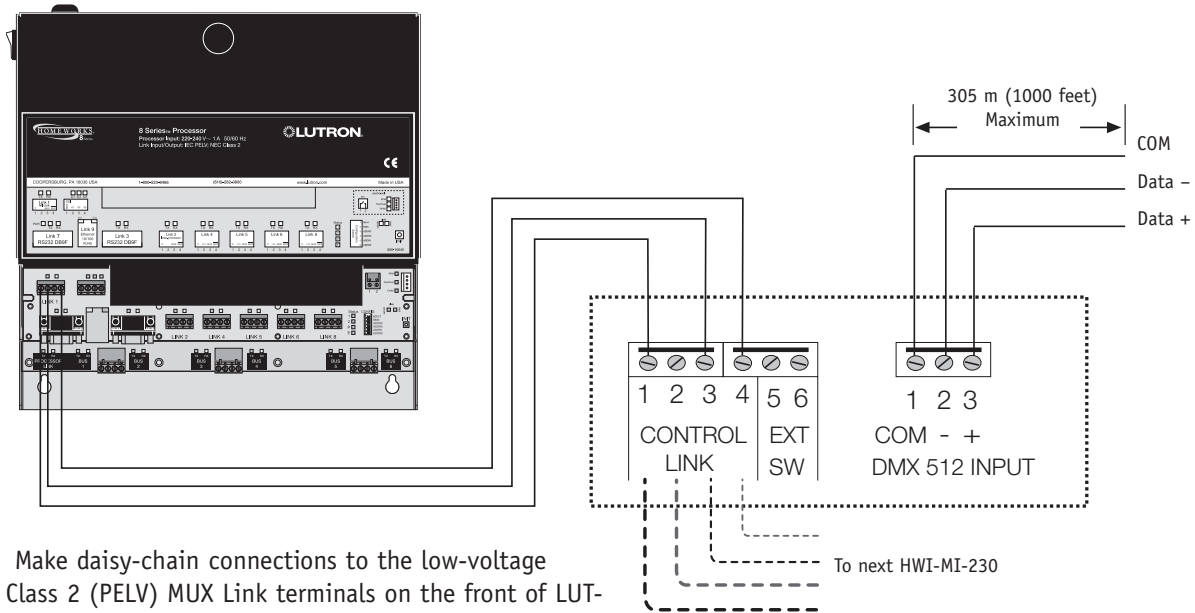


Figure 4 – LUT-DMX mounting

- Mount on a 10.2 mm (4 inch) square junction box.
- May also mount directly to the wall.
- Ensure that the metal casing is grounded. Connect a ground wire to the ground screw.
- Note that wires do not feed through the back of the unit.

# LUT-DMX – Wiring Diagrams



Make daisy-chain connections to the low-voltage Class 2 (PELV) MUX Link terminals on the front of LUT-DMX Interface.

Do not use T-taps. Run all wires in and out of terminal block.

Each terminal accepts up to two 1.0 mm<sup>2</sup> wires (18 AWG).

The LUT-DMX is normally powered on terminal 2 from an external HWI-MI (NOT the MI included in a processor). If there is NOT an external HWI-MI connected to the LUT-DMX then you must provide +12 V<sub>DC</sub> to terminal 2 from an auxiliary power supply.

Figure 5 – LUT-DMX wiring

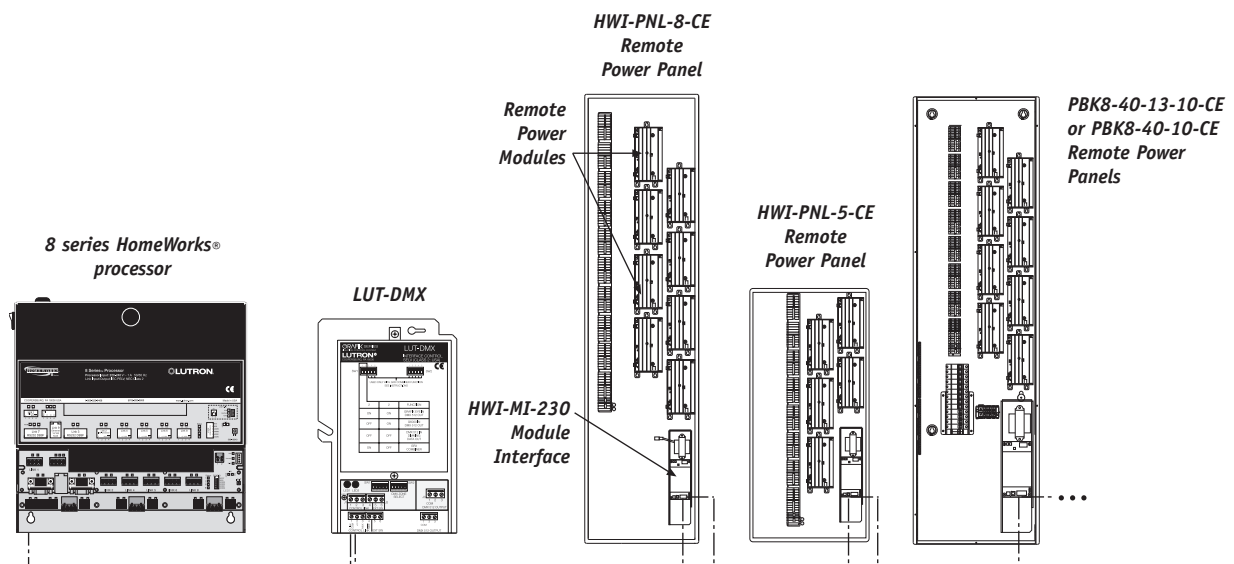



Figure 6 – Class 2 (PELV) wiring for system communications

# LUT-DMX

Model Numbers	LUT-DMX
Input Voltage	12 V 
Regulatory Approvals	CE, C-Tick, VDE
Environment	Ambient operating temperature: 0 °C to 40 °C (32 °F to 104 °F) Ambient operating humidity: 0-90% humidity, non-condensing. Indoor use only.
Cooling Method	Passive cooling.
Low-voltage Wire Type	Two pair [one pair 1.0 mm <sup>2</sup> (18 AWG), one pair 1.0 to 0.5 mm <sup>2</sup> (18-22 AWG) twisted shielded] Class 2 PELV cable.
Low-voltage Wiring Configuration	All processors on the same system must have the inter-processor communication links connected in a daisy-chain configuration.
Low-voltage Connections	To link 1 of HomeWorks processor - 6-pin terminal block (only 4 pins are used). To DMX equipment - 3-pin terminal block. Each of the terminal will accept up to two 1.0 mm <sup>2</sup> (18 AWG) wires.
ESD Protection	Meets or exceeds the IEC 61000-4-2 standard.
Miswire Protection	All terminal block inputs are miswire protected against wire reversals and shorts.
Shipping Weight	1.1 kg (2.4 pounds)

# Contact Closure Interface

Contact Closure Interfaces allow simple integration of the HomeWorks® system with other equipment throughout the house. Equipment such as motion sensors, photocells, and security systems are able to activate lighting scenes and other HomeWorks system events through the use of Contact Closure Input Interfaces (HWI-CCI-8). Equipment such as shades, screens, gates, spas, and thermostats can be controlled by the HomeWorks system through the use of Contact Closure Output Interfaces (HWI-CCO-8). In addition, both the HWI-CCI-8 and the HWI-CCO-8 provide an infrared (IR) input that can be used to initiate HomeWorks system events using IR remote controls.

Contact Closure Interfaces (HWI-CCI-8 and HWI-CCO-8) can be mounted in any of four different enclosures: HWI-LV32-CE, HWI-LV24-CE, HWI-LV17-230, and HWI-ENC-CC.

**Note:** seeTouch® keypads and 2-button keypads also include contact closure inputs.

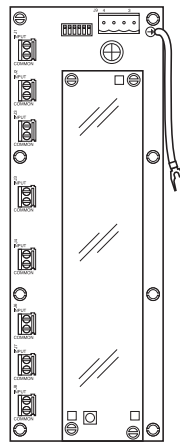
## CONTACT CLOSURE INPUT INTERFACES

Many electronic systems and devices have the capability to provide status or control in the form of dry contact closure outputs. Contact closure inputs are programmed in the same fashion as the buttons on a HomeWorks keypad. For example, a motion sensor can be connected to a CCI Interface and programmed to activate a “Welcome Home” scene.

Each of the contact closure inputs can be individually programmed as normally-open or normally-closed.

## CONTACT CLOSURE INPUT INTERFACE (MODEL HWI-CCI-8)

Each dry contact closure input has an LED indicator that shows the state of the connected device. The CCI-8 has an IR receiver that is programmed independently of the contact closure inputs. This receiver allows Lutron® Handheld IR Transmitters (GRX-IT, and GRX-8IT) to control the system. The IR receiver can recognize 11 different IR codes. The Lutron IR codes can be learned by most learning remotes, allowing audio/video remotes to control the lighting system.



## **Contact Closure Input Interface (HWI-CCI-8)**

## CONNECTION TO PROCESSOR

Each Contact Closure Interface uses one keypad address. Up to 32 can be connected to a configurable link on a HomeWorks processor using two pair [one pair 1.0 mm<sup>2</sup> (18 AWG), one pair 0.5 to 1.0 mm<sup>2</sup> (18-22 AWG) twisted shielded] Class 2/PELV cable. Contact Closure Interfaces must reside on a link that has been configured for keypads, and may be wired in a daisy-chain, home run, or T-tap configuration. The maximum total cable length of any wire run is 305 m (1,000 feet) with up to 10 keypads or interfaces. The maximum total cable length is 1220 m (4,000 feet).

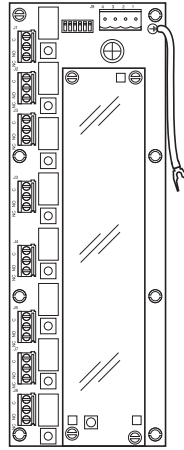


# Contact Closure Interface

## **CONTACT CLOSURE OUTPUT INTERFACE (MODEL HWI-CCO-8)**

Many electronic devices have dry contact closure inputs, allowing them to be controlled by other systems. The HomeWorks® system uses the Contact Closure Output board to control pumps, shades, thermostats, audio/video, and other equipment supplied with dry contact closure inputs. Each CCO interface has eight independent outputs and eight corresponding push buttons with LED indicators. Both normally-open and normally-closed relay contacts are provided for each output, and can be programmed to provide either momentary (pulsed) or maintained (latching) functionality.

These CCOs can be assigned to any keypad button or timeclock event in the same manner as any lighting load. In a typical application, a *HomeWorks* Keypad button can be programmed to activate an output on a CCO Interface that is connected to a motorised shade. The CCO Interface has an IR receiver. Refer to the HWI-CCI-8 for more information.



**Contact Closure Output interface  
(HWI-CCO-8)**





# Processors

# P5 Processors

HomeWorks® Processors comprise the major communication hub of a *HomeWorks* system. Each processor has communication links, which allow the processor to interact with various system components. System components communicate with a processor through low-voltage wiring or radio frequency. Some components must be connected to the processor through an interface. These interfaces are available as stand-alone components or as built-in components in specific models of processors.

## **8 SERIES**

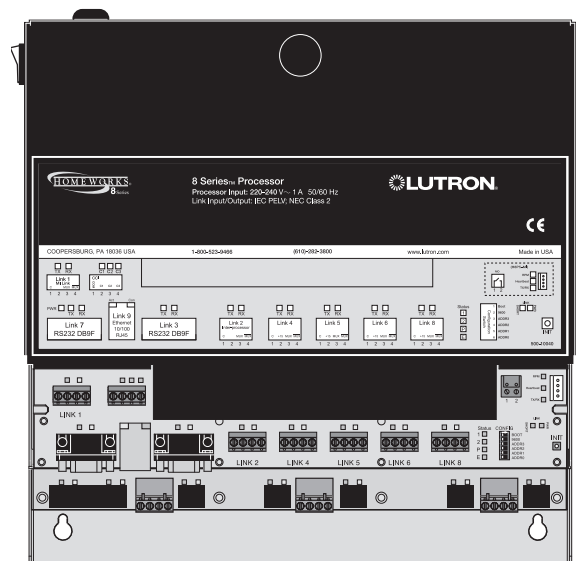
8 series processors may be used with any and all *HomeWorks* products, providing the most style and finish options. Remote power modules can only be used with the 8 series processor. The processor includes an ethernet link, two RS-232 links, a hybrid signal repeater link, and is capable of powering 350 keypad LEDs.

## **4 SERIES**

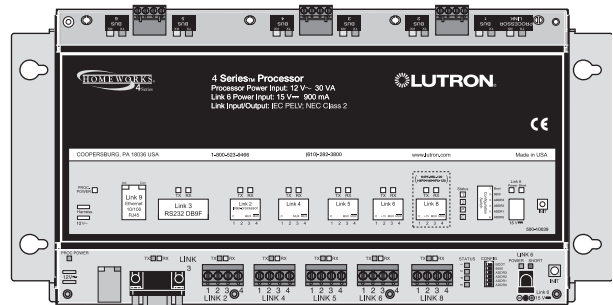
4 series processors cannot be used with Remote Power Modules. Dimming is accomplished via Maestro lighting controls, Rania® RF dimmers, wallbox power modules, or GRAFIK Eye® controls units. The processor includes an ethernet link, an RS-232 link, an optional hybrid signal repeater link, and is capable of powering 150 keypad LEDs via link 6.

## **4 AND 8 SERIES**

Both 4 and 8 series processors can control Sivoia QED® blinds and curtains with an interface. Each processor can control up to 256 lighting or *Sivoia QED* zones. A maximum of 16 processors can be used together in a single system. The 4 series and 8 series are compatible with each other and can be combined on the same system.



**8 Series Processor  
(H8P5-MI-H48-CE shown)**



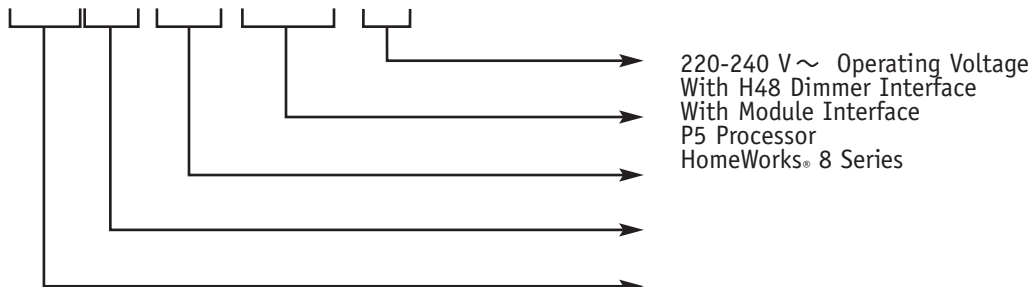
**4 Series Processor  
(H4P5-H48-HRL-CE shown)**

# P5 Processors

Model Number	Module Interface	H48 Dimmer Interface	# Configurable Links	Hybrid Signal Repeater Link	# RS-232 Ports	# Keypad LEDs	# Integral CCTs	Panel/Enclosure
H8P5-CE	External	External	4	Yes	2	350	3	HWI-LV32-CE
H8P5-MI-CE	Included	External	4	Yes	2	350	3	HWI-PNL-8-CE
H8P5-H48-CE	External	Included	4	Yes	2	350	3	HWI-LV32-CE
H8P5-MI-H48-CE	Included	Included	4	Yes	2	350	3	HWI-PNL-8-CE
H4P5-HRL-CE	Not Available	External	3	Yes	1	150	0	HWI-LV24-CE
H4P5-H48-HRL-CE	Not Available	Included	3	Yes	1	150	0	HWI-LV24-CE

Example Model Number

## H8P5-MI-H48-CE



# P5 Processors

## PROCESSOR LINKS

Each Processor has several communication links, which allow the processor to interact with other system equipment. Some links are designated for specific components, and other links are configurable through the HomeWorks® Illumination Software, allowing the system to be customised to meet the needs of the project.

### Communication Link 1 (8 series processor only):

This link is designated for communication with Module Interfaces. It must be wired in a daisy-chain configuration and requires a link terminator at the last Module Interface when the total cable length exceeds 15 m (50 feet).

**Communication Link 2:** This link is designated for communication between multiple processors. It must be wired in a daisy-chain configuration and requires terminators at both ends of the link when the total cable length exceeds 15 m (50 feet).

**Communication Links 3 and 7 (Link 7 is only available on the 8 series processor):** These links are multipurpose RS-232 ports. One port is initially used for programming the processor. When a port is not being used for programming, the RS-232 ports can be used for two-way serial communications with A/V equipment, touch screens, security systems, HVAC, and home automation controls. Maximum cable length is 15 m (50 feet).

**Communication Links 4, 5, and 6:** Each of these links can be configured to communicate with one of the following: keypads and interfaces, Maestro® local lighting controls (via an H48 dimmer interface), Sivoia QED® drives (via HW-Q96 interface) or GRAFIK Eye® preset local lighting controls and Wallbox Power Modules.

**Communication Link 8:** On an 8 series processor, this link may be configured for any of the functions listed for links 4, 5, and 6 or as a hybrid signal repeater link. On a 4 series processor, this is an optional link only for hybrid signal repeaters.

### Communication Link 9:

This link is an ethernet port. The ethernet port can be used for uploading programming information or communication with other systems, such as A/V equipment, security systems, HVAC, and home automation equipment. Maximum cable length is 100 m (328 feet).

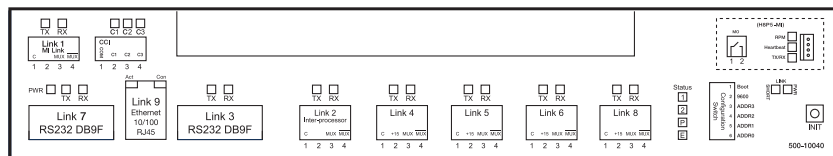


Figure 1 - 8 Series Processor Link Identification

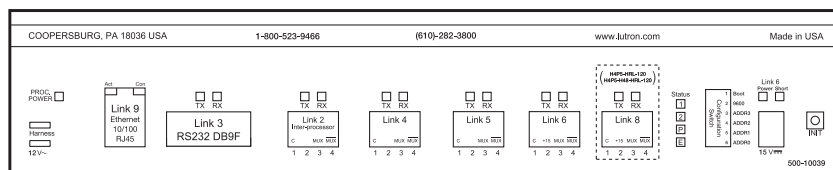


Figure 2 - 4 Series Processor Link Identification

# P5 Processors

<b>Communication link information</b>					
<b>Non-configurable links</b>	<b>Function</b>	<b>Link capacity</b>	<b>Wiring configuration</b>	<b>Terminators?</b>	<b>Maximum wire length and type</b>
link 1 (8 series only)	link to Remote Power Modules	16 Module Interfaces, each controlling maximum 8 RPMs	daisy-chain	at last Module Interface <sup>2</sup>	305 m (1,000 feet) total <sup>1</sup> , type A
link 2	link to other processors	16 processors	daisy-chain	at first and last processor <sup>2</sup>	305 m (1,000 feet) total <sup>1</sup> , type A
links 3 and 7 (7 available on the 8 series only)	RS-232 port	n/a	point-to-point	No	15 m (50 feet) maximum, type B
<b>Configurable links</b>	<b>Possible function</b>	<b>Link capacity</b>	<b>Wiring configuration</b>	<b>Terminators?</b>	<b>Maximum wire length and type</b>
links 4*, 5, and 6 (configure each link to communicate with one of the following: keypads and contact closure interfaces, Maestro® controls, or GRAFIK Eye® controls and WPMs).	link to keypads and Contact Closure Interfaces	32 devices	any (Daisy-chain, Star, T-tap, etc.)	no	305 m (1,000 feet) per home run, type A <sup>3</sup> 1220 m (4,000 feet) total
	link to H48 dimmer interface and Sivoia QED® interfaces	4 H48s (each controlling up to 48 wired Maestro controls) and Q96s (each controlling up to 96 Sivoia QEDs)	daisy-chain	at processor and last Dimmer Interface <sup>2</sup>	305 m (1,000 feet) total, type A
	link to GRAFIK Eye/WPM	8 GRAFIK Eye/WPMs	daisy-chain	no	610 m (2,000 feet) total, type A
	any function of link 4, 5, 6	see above	see above	see above	see above
link 8 (8 series)	or hybrid signal repeater link	5	daisy-chain	no	305 m (1,000 feet) per home run, type A <sup>3</sup> 1220 m (4,000 feet) total
link 8 (4 series)	hybrid signal repeater link	5	daisy-chain	no	305 m (1,000 feet) per home run, type A <sup>3</sup> 1220 m (4,000 feet) total
link 9	ethernet	–	point-to-point	no	100 m (328 feet)

# P5 Processors

## *Notes from previous page*

**Wire type A** = two pair [one pair 1.0 mm<sup>2</sup> (18 AWG), one pair 0.5 to 1.0 mm<sup>2</sup> (18-22 AWG) twisted shielded] Class 2/PELV wire. Lutron® wire GRX-CBL-346S-500 may be used.

**Wire type B** = standard RS-232 cable.

<sup>1</sup> To increase link distance, *see page 12.2*.

<sup>2</sup> Terminators required if total cable length exceeds 15 m (50 feet).

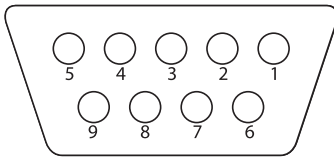
<sup>3</sup> Maximum ten keypads recommended per 305 m (1,000 feet) wire run; maximum 1220 m (4,000 feet) total wire length.

## **Important processor note:**

\*If the processor has an integral H48 interface, Link 4 **MUST** be configured for H48 interfaces.



# P5 Processors

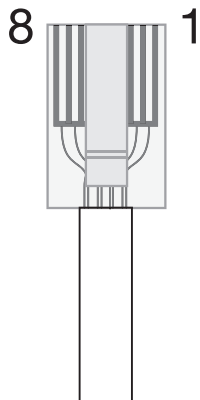
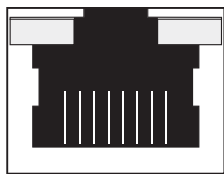


**DB9 female connector for RS-232 communication**

HomeWorks® processor is considered as a DCE (Data Communication Equipment) for the purpose of RS232 serial communication.

Pin Number	Pin Name	Description for Processor Connector	Required for Hardware Handshaking	Required for Simple Communications (Hardware Handshaking Disabled)
1	DCD	Data Carrier Detect (input)		
2	TXD	Transmit Data (output)	X	X
3	RXD	Receive Data (input)	X	X
4	DSR	Data Set Ready (input)	X	
5	GND	Ground	X	X
6	DTR	Data Terminal Ready (output)	X	
7	CTS	Clear To Send (input)	X	
8	RTS	Request To Send (output)	X	
9	RI	Ring Indicate (input)		

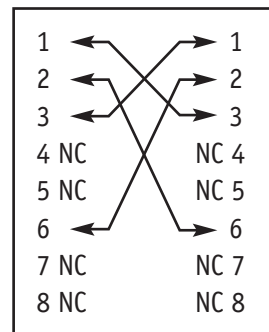
**Figure 3 - RS-232 Port Specifications**



PIN	Processor	Ethernet Hub/Switch
1	Transmit +Ve	Receive +Ve
2	Transmit -Ve	Receive -Ve
3	Receive +Ve	Transmit +Ve
4	No Connection	No Connection
5	No Connection	No Connection
6	Receive -Ve	Transmit -Ve
7	No Connection	No Connection
8	No Connection	No Connection

**Crossover Cable Configuration**

A crossover cable is used when connecting the processor directly to a laptop or other non-hub device (A/V systems, HVAC, etc.)



**Figure 4 - Ethernet Port and Cable Configuration**

# 8 Series P5 Processors

Model Numbers	H8P5-CE: Processor without integral interfaces H8P5-MI-CE: Processor with integral Module Interface (MI) H8P5-H48-CE: Processor with integral Dimmer Interface (H48) H8P5-MI-H48-CE: Processor with integral Module Interface (MI) and integral Dimmer Interface (H48)
Input Voltage	220-240 V ~ 50/60 Hz
Regulatory Approvals	CE, C-Tick, VDE
Environment	Ambient operating temperature: 0 °C to 40 °C (32 °F to 104 °F) Ambient operating humidity: 0-90% humidity, non-condensing. Indoor use only.
Cooling Method	Passive cooling.
Line-Voltage Connections	Mates with Lutron®-provided 2-pin pigtail on DIN-rail terminal block. Power switch provided on top left of processor. Terminal blocks should be tightened to 0.40 to 0.57 n·m (3.5 to 5.0 inch-pounds).
Low-voltage Wire Type	Two pair [one pair 1.0 mm <sup>2</sup> (18 AWG), one pair 1.0 to 0.5 mm <sup>2</sup> (18-22) twisted shielded] Class 2 PELV cable.
Low-voltage Wiring Configuration	All processors on the same system must have the inter-processor communication links connected in a daisy-chain configuration.
Low-voltage Connections	One 4-pin removable terminal block. Each of the four terminals will accept up to two 1.0 mm <sup>2</sup> (18 AWG) wires. Up to two standard female DB-9 serial RS-232 connections.
ESD Protection	Meets or exceeds the IEC 61000-4-2 standard.
Surge Protection	Meets or exceeds ANSI/IEEE standard c62.41.
Miswire Protection	All terminal block inputs are over-voltage and miswire protected against wire reversals and shorts. 15 V communications link power is short-circuit protected.
Power-Failure Memory	Lithium battery provides ten years of data retention.
Internal Timeclock	Accuracy ± 1 minute per year.
Shipping Weight (all model numbers)	4.1 kg (9.0 pounds)

# 8 Series P5 Processors – Mounting Locations

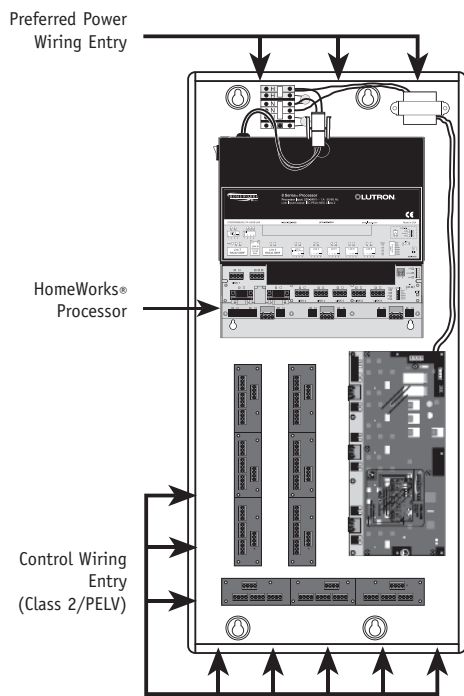


Figure 5 – Mounting Location in an HWI-LV32-CE

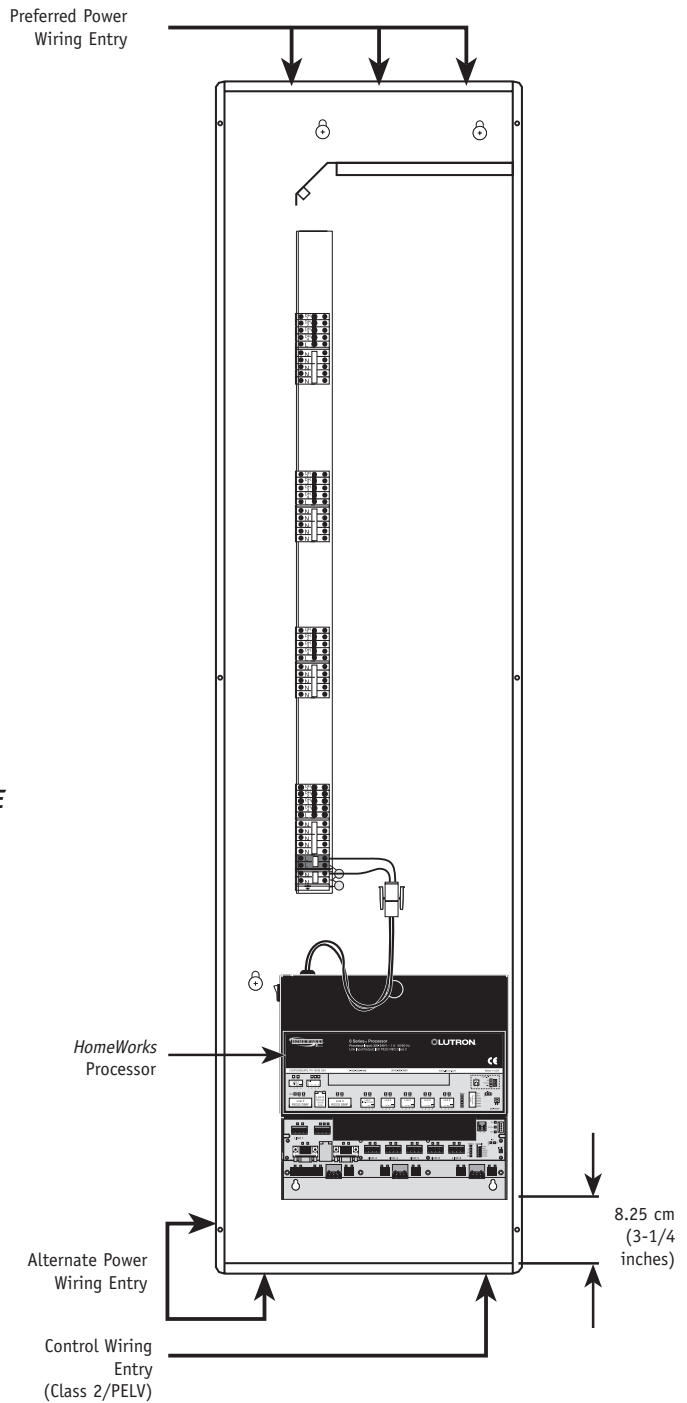


Figure 6 – Mounting Location in an HWI-PNL-8-CE

# 8 Series P5 Processors

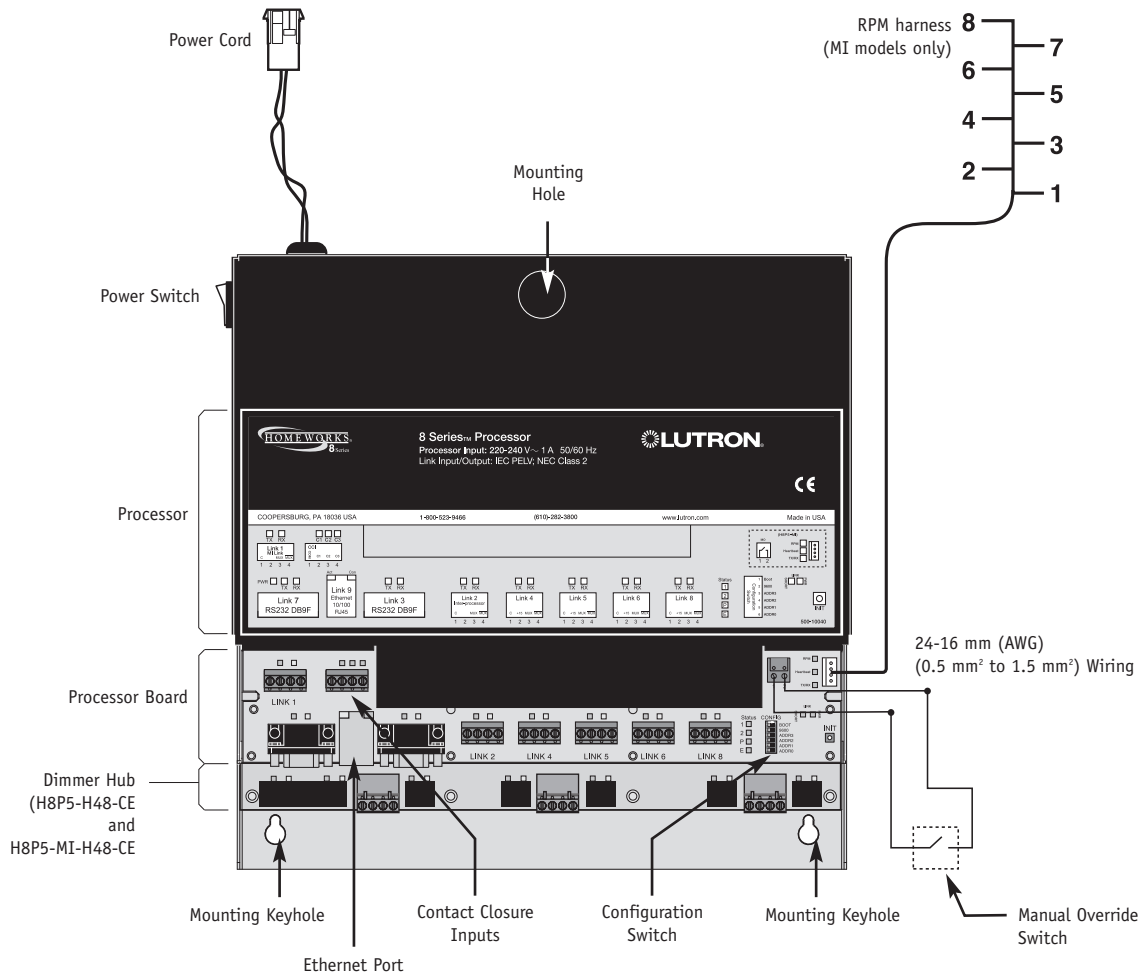
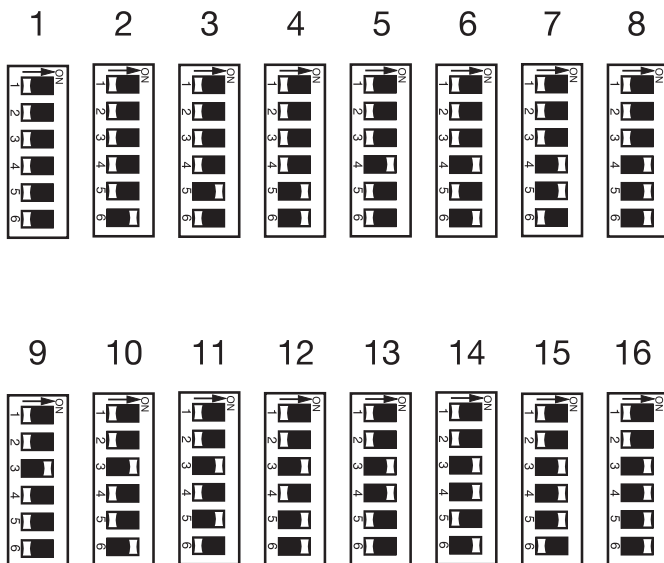
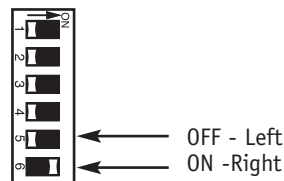


Figure 7 - 8 Series Processor  
(H8P5-MI-H48-120 shown)

## Address #



Example: Setting Switch #6 ON.

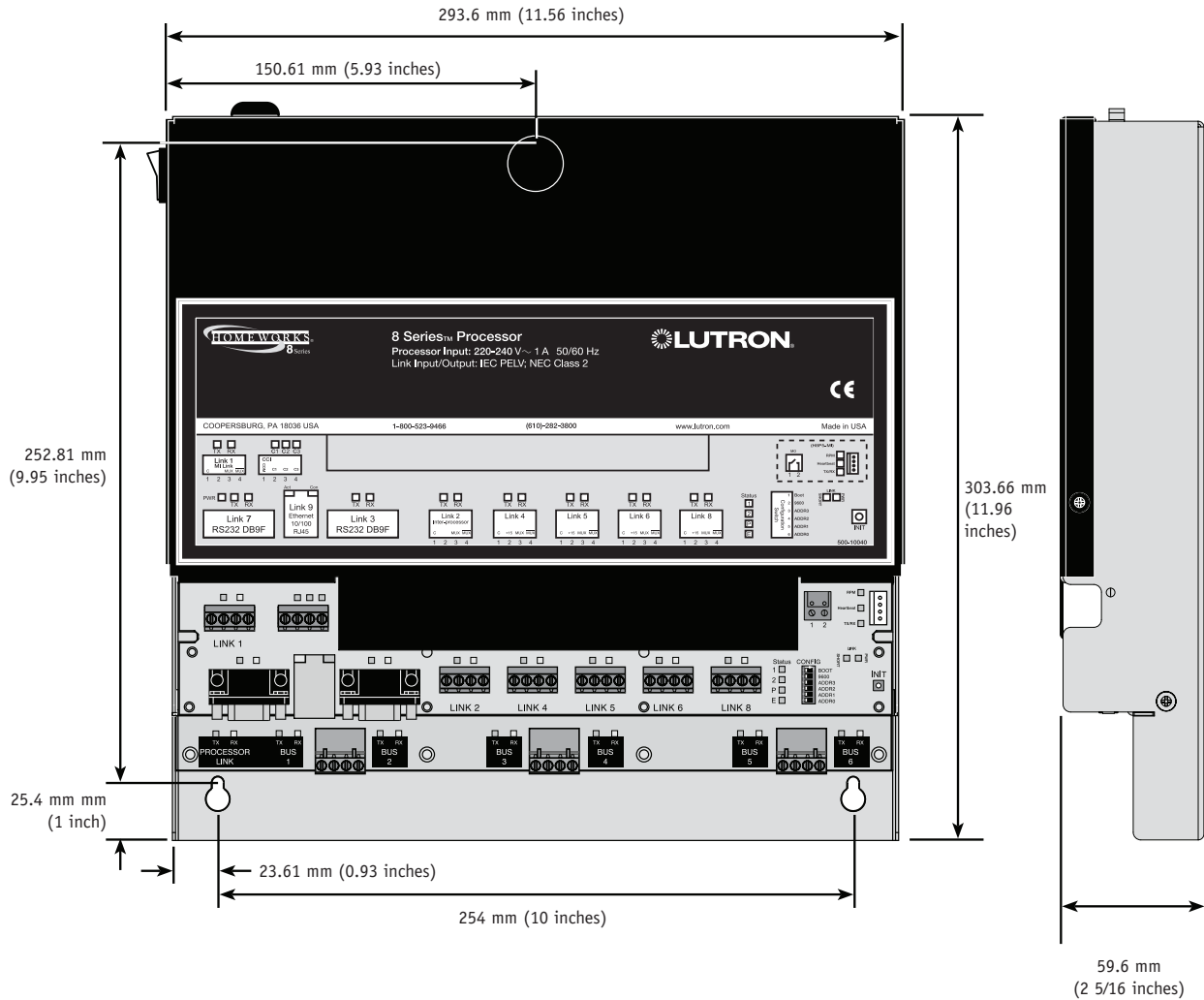


## Configuration DIP Switches

DIP Switch	OFF	ON
1	Normal Mode	Boot Mode
2	User-Configured Baud Rate	9600 Baud
3-6	Address	

# 8 Series P5 Processor Dimensions

Please note: Processor warranty will be void if not placed inside an approved Lutron® enclosure.



Note: All 8 series processors have the same dimensions

Figure 1 – H8P5-MI-H48-CE processor dimensions

## 4 Series P5 Processors

Model Numbers	H4P5-HRL-CE: Processor with Hybrid Signal Repeater Link. H4P5-H48-HRL-CE: Processor with integral Dimmer Interface (H48) and a Hybrid Signal Repeater Link.
Input Voltage <sup>1</sup>	15-24 V ~ 50/60 Hz
Regulatory Approvals	CE, C-Tick, VDE
Environment	Ambient operating temperature: 0 °C to 40 °C (32 °F to 104 °F) Ambient operating humidity: 0-90% humidity, non-condensing. Indoor use only.
Cooling Method	Passive cooling.
Line-Voltage Connections	Mates with Lutron®-provided 2-pin pigtail on DIN-rail terminal block. Power switch provided on top left of processor. Terminal blocks should be tightened to 0.40 to 0.57 n·m (3.5 to 5.0 inch-pounds).
Low-voltage Wire Type	Two pair [one pair 1.0 mm <sup>2</sup> (18 AWG), one pair 1.0 to 0.5 mm <sup>2</sup> (18-22 AWG) twisted shielded] Class 2 PELV cable.
Low-voltage Wiring Configuration	All processors on the same system must have the inter-processor communication links connected in a daisy-chain configuration.
Low-voltage Connections	One 4-pin removable terminal block. Each of the four terminals will accept up to two 1.0 mm <sup>2</sup> (18 AWG) wires. Up to two standard female DB-9 serial RS-232 connections.
ESD Protection	Meets or exceeds the IEC 61000-4-2 standard.
Surge Protection	Meets or exceeds ANSI/IEEE standard c62.41.
Miswire Protection	All terminal block inputs are over-voltage and miswire protected against wire reversals and shorts. 15 V communications link power is short-circuit protected.
Power-Failure Memory	Lithium battery provides ten years of data retention.
Internal Timeclock	Accuracy ± 1 minute per year.
Shipping Weight	2.5 kg (5.5 pounds)

<sup>1</sup> Link 6 powered with a separate power supply (see page 12.7)

# 4 Series P5 Processors

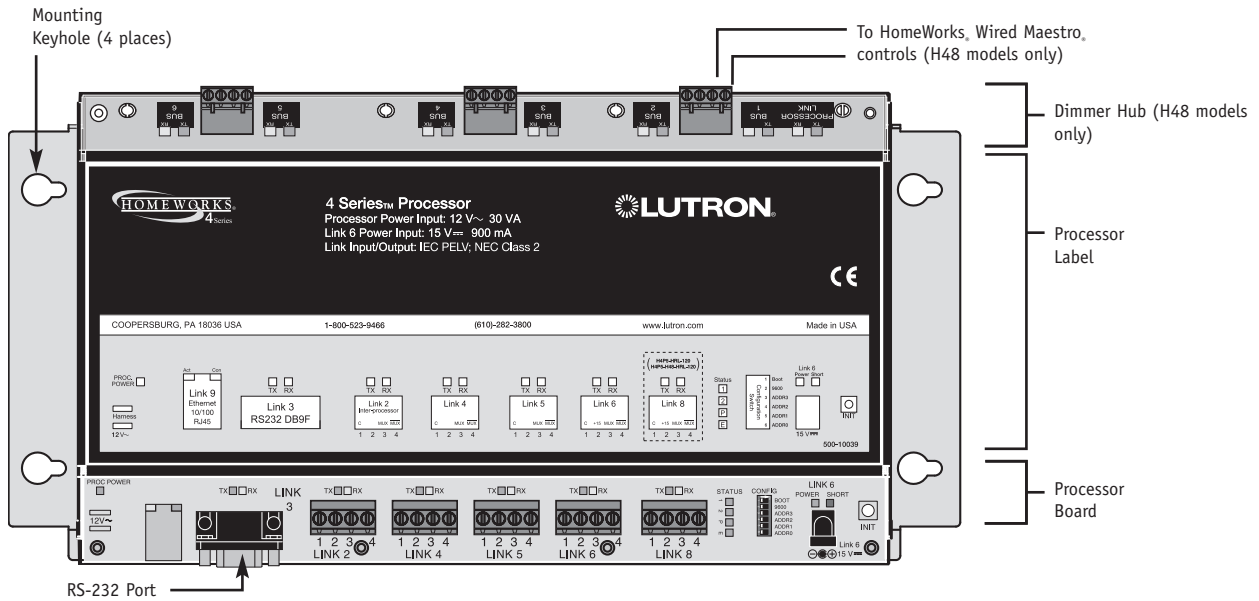
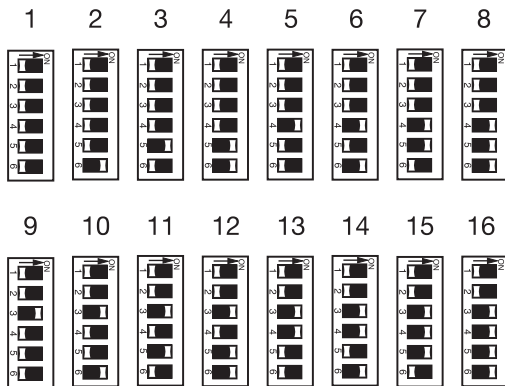


Figure 8 – 4 Series Processor (H4P5-H48-HRL-CE shown)

### Configuration Switch Functions

DIP Switch	Function
1	Boot Mode. Unless prompted by the HomeWorks Utility, this switch should always be in the DOWN position.
2	UP = 9600 Baud, DOWN = User selected Baud.
3-6	Processor Address. See Figure 3, below.



Example: Setting Switch #6 ON

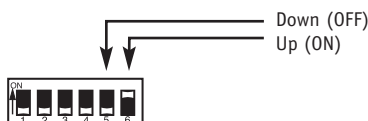


Figure 9 – Address DIP Switch Settings

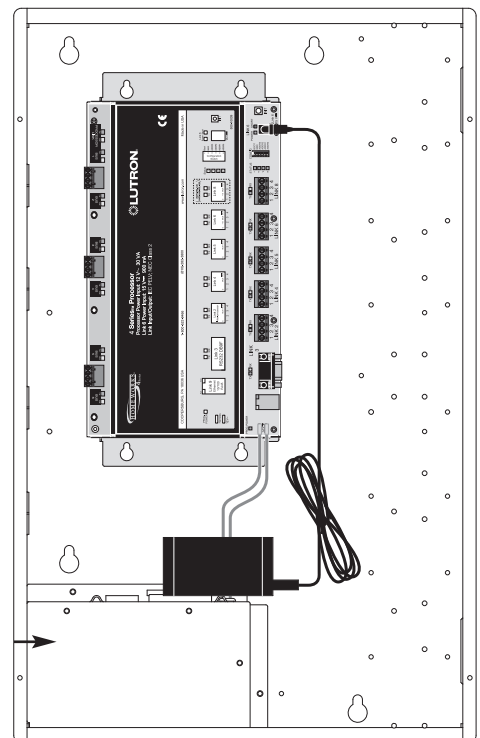


Figure 10 – Mounting Location in an HWI-LV24-CE





# Connecting Multiple Processors

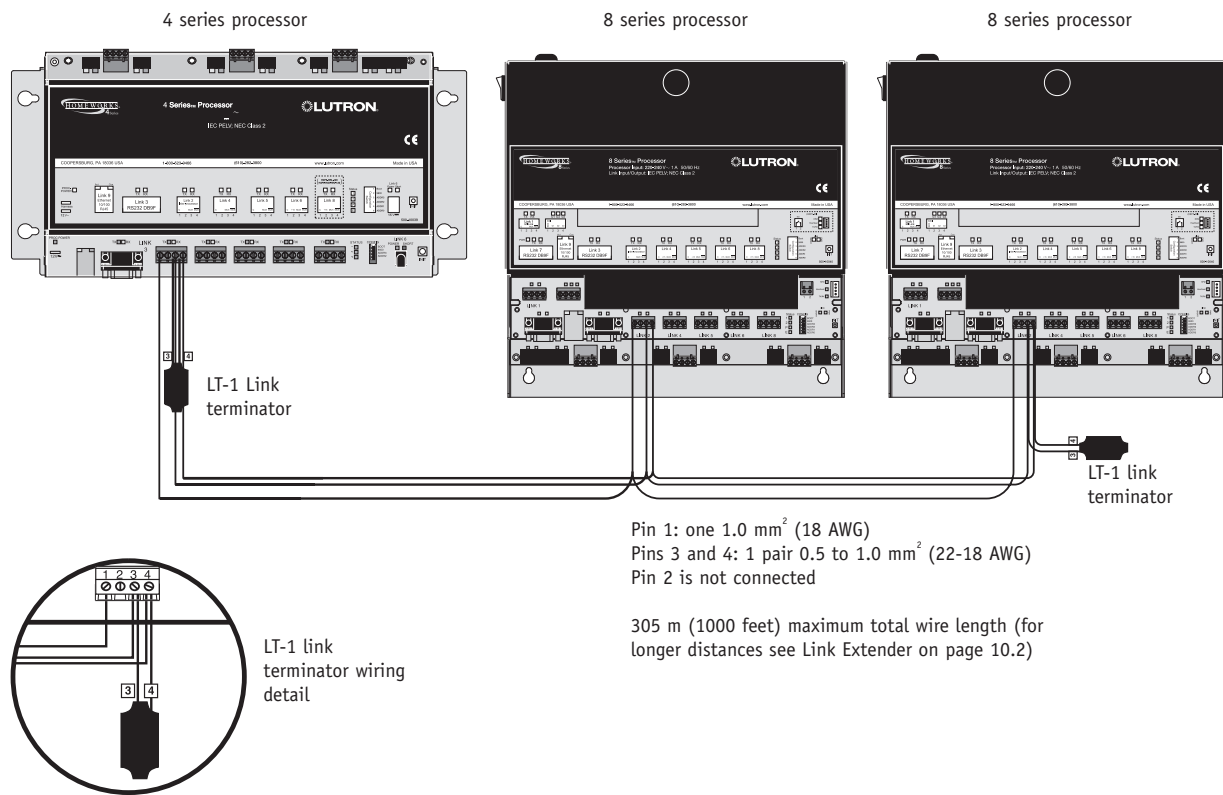


Figure 3 – daisy-chained HomeWorks® processors





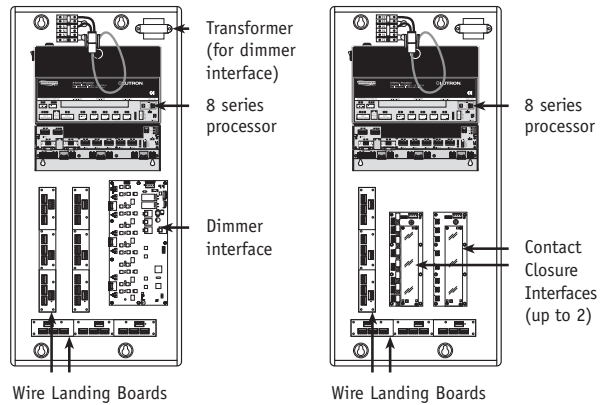
# Low-voltage Enclosures

# Low-voltage Enclosures

Low-voltage enclosures are available in four different sizes. The number of enclosures and the types of components within them are customised to fit the size, lighting plan, and design of a home. Low-voltage enclosures can be distributed throughout the home near the rooms they are controlling to provide maximum flexibility.

## **81 CM (32 INCHES) LOW-VOLTAGE ENCLOSURE (MODEL HWI-LV32-CE)**

81 cm low-voltage enclosures accommodate several components including 8 series processors, dimmer interfaces, Contact Closure Interfaces, and wire landing boards. Shown are a few of the possible configurations. Low-voltage enclosures cannot accommodate Remote Power Modules (RPMs).

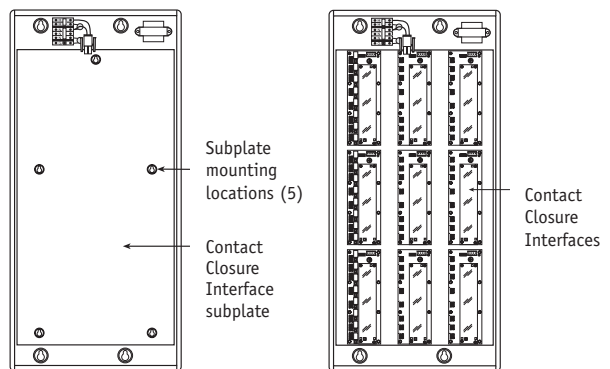


- 8 series processor (1)
- Wire Landing Boards (3 maximum)
- Dimmer interface (1)

- 8 series processor (1)
- Wire Landing Boards (2 maximum)
- Contact Closure Interfaces (2 maximum)

## **CONTACT CLOSURE INTERFACE SUBPLATE (MODEL HWI-SUB32-CC9)**

The HomeWorks® Contact Closure Interface subplate installs in the HWI-LV32-CE enclosure allowing up to nine Contact Closure Interfaces to be mounted in one panel.

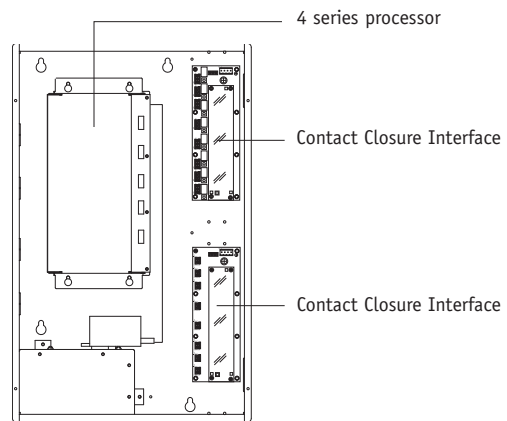


- Contact Closure Interfaces (9 maximum)

# Low-voltage Enclosures

## 61 CM (24 INCHES) LOW-VOLTAGE ENCLOSURE (MODEL HWI-LV24-CE)

The 61 cm (24 inches) low-voltage enclosure accommodates several components including 4 series processors, Contact Closure Interfaces and Wire Landing Boards. Low-voltage enclosures cannot accommodate Remote Power Modules.

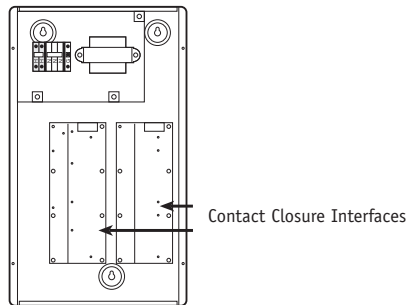


- 4 series processor (1)
- Contact Closure Interfaces (2 maximum)
- Wire Landing Boards (2 maximum)

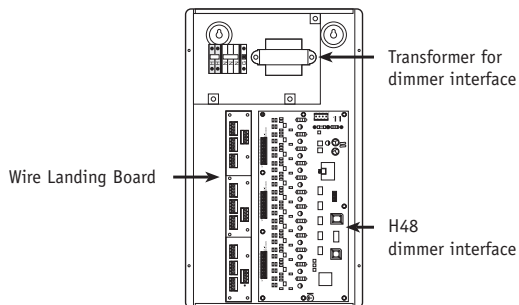
# Low-voltage Enclosures

## ***44 CM (17 INCHES) LOW-VOLTAGE ENCLOSURE (MODEL HWI-LV17-230)***

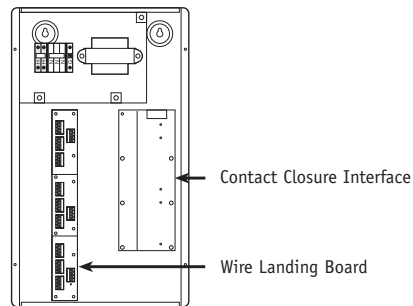
44 cm low-voltage enclosures accommodate several components including dimmer interfaces, Contact Closure Interfaces, and Wire Landing Boards. Shown are a few of the possible configurations.



- Contact Closure Interfaces (2 maximum)



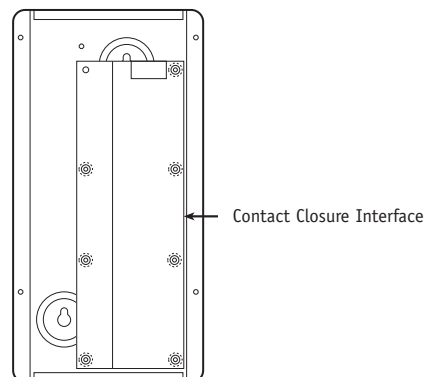
- Dimmer Interface (1)
- Wire Landing Board (1)



- Contact Closure Interface (1)
- Wire Landing Board (1)

## ***25 CM (10 INCHES) LOW-VOLTAGE ENCLOSURE (MODEL HWI-ENC-CC)***

The 25 cm low-voltage enclosure accommodates one Contact Closure Interface (HWI-CCI-8 or HWI-CCO-8). Shown is the mounting configuration.



- Contact Closure Interface (1)



# Wireless Equipment

***Important Note:***

Regulations for products with radio frequency change from country to country. Therefore, HomeWorks® products with radio frequency are not available in all countries.

*HomeWorks* products with radio frequency have been developed around two different frequencies—434 MHz and 868 MHz. You should use the HomeWorks software to select the appropriate frequency for the regulations of your country.

Contact Lutron® for further assistance.

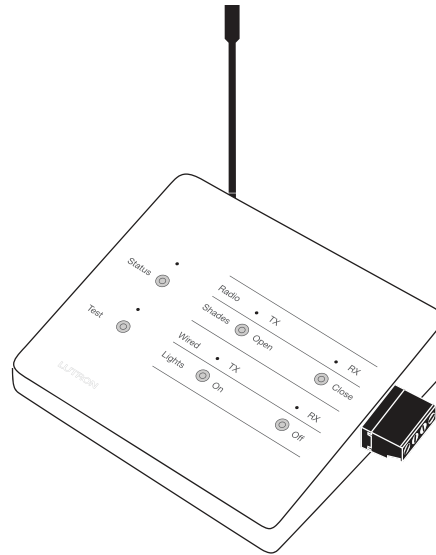
# Hybrid Repeater

## **HYBRID REPEATER**

The HomeWorks® hybrid repeater allows P5 Processors to communicate with wireless controls. All control keypads must be located within 9 m of a hybrid repeater. Up to five hybrid repeaters can be added to each RF capable P5 processor. Up to 32 wireless keypads can be used in a single HomeWorks system. One processor and its hybrid repeaters can control up to 64 Rania® RF dimmers.

## **COMMUNICATION TO P5 PROCESSOR**

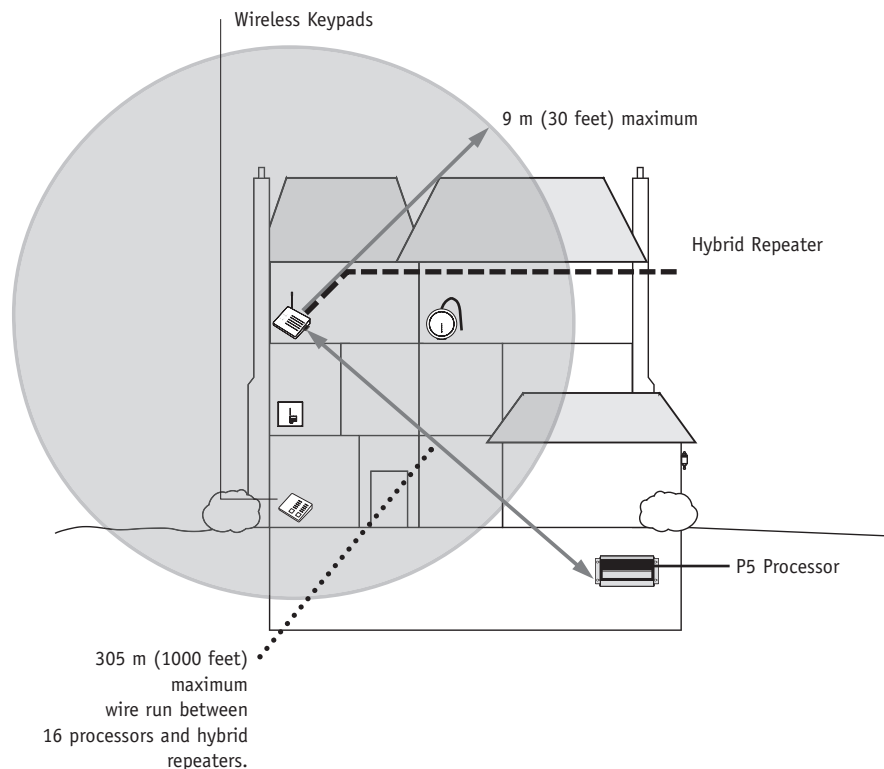
The hybrid repeater connects to 4 or 8 series processors on link 8. Additional repeaters must be within 18 m of another repeater for wireless communication. They may also be wired to another repeater or the processor.



**Hybrid Repeater**  
**HR-REP-868**  
**HR-REP-434**

## **RF SYSTEM COMMUNICATION**

Wireless controls must be located within 9m of a hybrid repeater. Multiple hybrid repeaters may be necessary to provide adequate coverage. Coverage limited to 232 m<sup>2</sup> (2500 ft<sup>2</sup>) per repeater.



**Figure 1 – RF System Communication**



# Hybrid Repeater

## RF TX/RX LEDS

Indicate RF Link activity.

## STATUS BUTTON

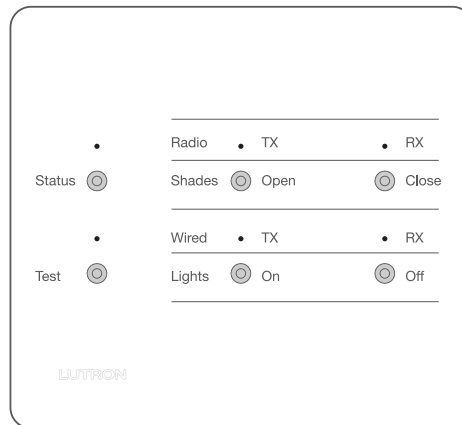
Used when addressing the Hybrid Repeater.

## STATUS LED

Indicates the status of the HomeWorks® system.

## LIGHTS ON/OFF BUTTON

Used to test the Rania® RF dimmers.



## WIRED TX/RX LEDS

Indicate Wired Link activity.

## TEST BUTTON

Activates RF communication tests. To activate the tests, press and hold the TEST Button until the TEST LED begins to flash.

## TEST LED

A slow flash indicates RF communications tests are in progress.

## SHADES OPEN/CLOSE BUTTONS

Used to test the RF Sivoia QED® shades.

Figure 2 – Operation

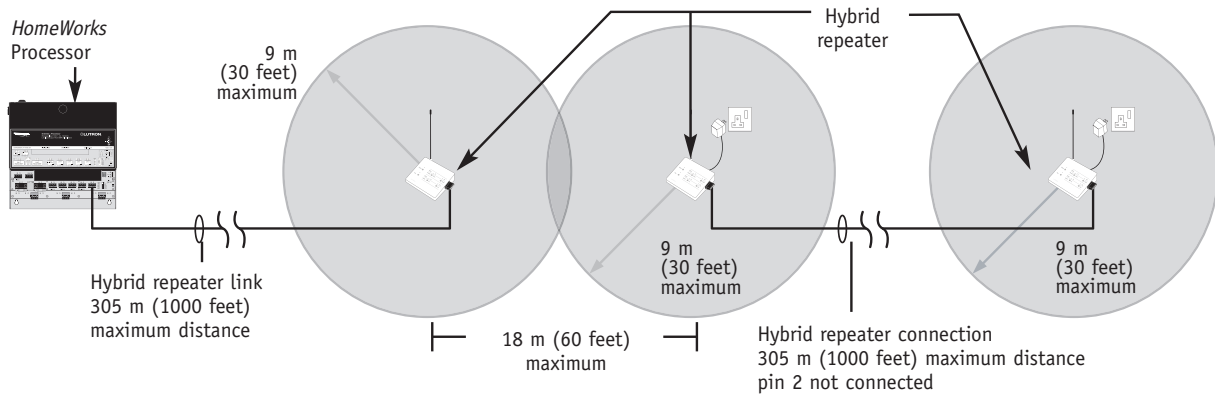



Figure 3 – Wiring and Communication Overview

# Hybrid Repeater

Model Number	HR-REP-434 (operates near 434 MHz) HR-REP-868 (operates near 868 MHz)
Input Voltage	9 V  transformer or by link 8 on processor.
Regulatory Approvals	CE, C-Tick, VDE
Environment	Ambient operating temperature: 0 °C to 40 °C (32 °F to 104 °F) Ambient operating humidity: 0-90% humidity, non-condensing. Indoor use only.
Low-voltage Wire Type	Two pair [one pair 1.0 mm <sup>2</sup> (18 AWG), one pair 1.0 to 0.5 mm <sup>2</sup> (18-22 AWG) twisted shielded] Class 2/PELV wire. Lutron® wire model # GRX-CBL-346S-500 may be used.
Low-voltage Wiring Configuration	Daisy-chain. Termination not required. Total length of wire on any link cannot exceed 305 m (1,000 feet) per wire run.
Low-voltage Connections	One 4-pin removable terminal block. Terminal block will accept up to four 1.0 mm <sup>2</sup> (18 AWG) wires. Pin 2 should not be connected if using included transformer.
Addressing	Via the HomeWorks® Illumination Software, using unique device serial numbers. Units must be installed prior to addressing. Counts as 1 of 5 on a 4 or 8 series processor.
Diagnostics	Test button provides RF communication check. LEDs show communication link status.
ESD Protection	Meets or exceeds the IEC 61000-4-2 standard.
Surge Protection	Meets or exceeds ANSI/IEEE standard c62.41.
Coverage	Each wireless table keypad must be within 9 m (30 feet) of a hybrid signal repeater.
Shipping Weight	0.7 kg (1.5 pounds)
Keypad LED Count	15 Keypad LEDs (if powered via Link 8)

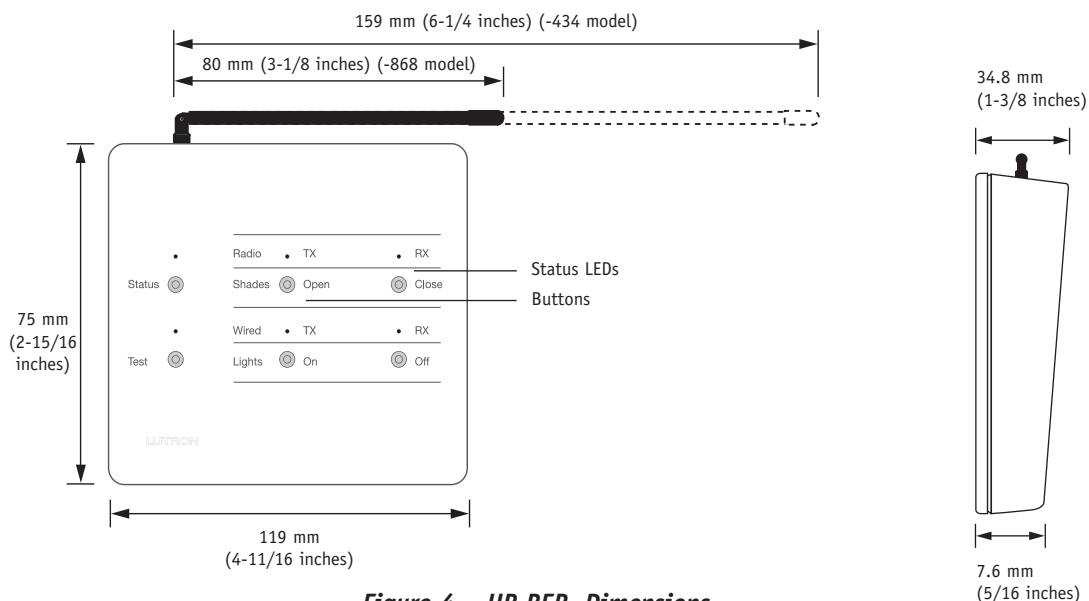


Figure 4 – HR-REP- Dimensions


# Wireless Tabletop Keypads

Wireless tabletop keypads provide maximum flexibility to locate the devices where the homeowner can conveniently monitor and control lighting, window treatments, and other home systems. Tabletop keypads are ideal for night stands, coffee tables, and kitchen counters.

## **FEATURES**

Wireless tabletop keypads are available in a variety of button configurations. Plastic and metal faceplates are available and each keypad includes custom engraving. seeTouch units have backlighting (see below) so that they can be read in a dark room. Units are available at RF frequencies of 434 MHz and 868 MHz.

## **POWER OPTIONS**

Wireless tabletop keypads can be powered from 2 AAA batteries and/or from a 9 V  plug-in adapter (ordered separately). When a plug-in adapter is used, the status LEDs and backlighting will always be operational. If battery power is used, the status LEDs and backlighting will turn off after the unit has been unused several seconds.

## **COMMUNICATION TO HYBRID SIGNAL REPEATER**

All wireless tabletop keypads must be located within 9 m (30 feet) of a hybrid signal repeater. Each HomeWorks P5 Processor with a hybrid signal repeater link is capable of controlling up to 32 wireless tabletop keypads.

## **ORDERING METHOD**

- 1) Order keypad with buttons/faceplate.  
**HRT-model-colour**  
Available colours: *snow (SW)*  
or *midnight (MN)* only
- 2) After engraving is determined, order engraved faceplate with same number of buttons as control.  
**HKT-model-colour-E**  
**LBK-model-colour**  
See section 13 for colours and finishes.
- 3) Order plug-in transformers if needed.  
See page 10.7.

## **seeTouch BUTTON**



### **5-Button**

Keypad: HRTS-5RL-1-XX (868 MHz)  
HRTS-5RL-2-XX (434 MHz)  
Faceplate only: LBK-T5RL-XX-E  
Description: 5-button with raise/lower



### **10-Button**

Keypad: HRTS-10RL-1-XX (868 MHz)  
HRTS-10RL-2-XX (434 MHz)  
Faceplate only: LBK-T10RL-XX-E  
Description: 10-button with raise/lower



### **15-Button**

Keypad: HRTS-15RL-1-XX (868 MHz)  
HRTS-15RL-2-XX (434 MHz)  
Faceplate only: LBK-T15RL-XX-E  
Description: 15-button with raise/lower

## **LARGE BUTTON**



### **6-Button**

Keypad: HRT-6LRL-434-XX  
HRT-6LRL-868-XX  
Faceplate only: HKT-6LRL-XX-E  
Description: 6-button with raise/lower

## **SLIM BUTTON**



### **5-Button**

Keypad: HRT-5RL-868-XX  
HRT-5RL-434-XX  
Faceplate only: HKT-5RL-XX-E  
Description: 5-button with master on/off and raise/lower



### **10-Button**

Keypad: HRT-10RL-868-XX  
HRT-10RL-434-XX  
Faceplate only: HKT-10RL-XX-E  
Description: 10-button with master on/off and raise/lower



### **15-Button**

Keypad: HRT-15RL-868-XX  
HRT-15RL-434-XX  
Faceplate only: HKT-15RL-XX-E  
Description: 15-button with master on/off and raise/lower

# Wireless Tabletop Keypads

Model Numbers	All wireless tabletop keypads.
Input Voltage	9 V $\equiv$ (with plug-in low-voltage transformer). 3 V $\equiv$ (with two AAA batteries).
Regulatory Approvals	CE, C-Tick, VDE
Frequency of Operation	Near 434 MHz or near 868 Mhz
Environment	Ambient operating temperature: 0 °C to 40 °C (32 °F to 104 °F) Ambient operating humidity: 0-90% humidity, non-condensing. Indoor use only.
Cooling Method	Passive cooling.
Addressing	Via the HomeWorks® Software, using unique device serial numbers. Counts as 1 of the 32 keypads addresses on the hybrid repeater link.
Diagnostics	LEDs provide diagnostics for troubleshooting.
ESD Protection	Meets or exceeds the IEC 61000-4-2 standard.
Surge Protection	Meets or exceeds ANSI/IEEE standard c62.41.
Mounting	Units powered by plug-in transformer must be located near a power receptacle. Unit must be placed within 9 m (30 feet) of hybrid signal repeater.
Shipping Weight	0.1 kg (0.3 pounds)
Keypad Link LED Count	0

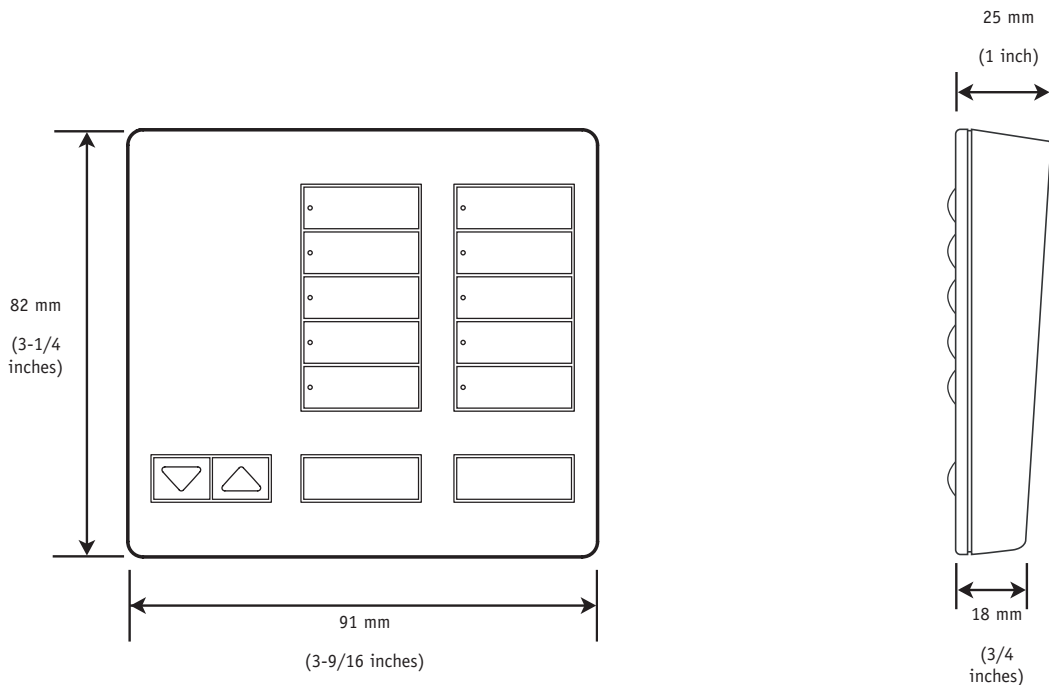


Figure 5 – Dimensions

# Transformers for Wireless Equipment

low-voltage transformers may be used to supply power to the hybrid signal repeater and the tabletop keypads. The transformers are available in plug styles for the U.K. and Europe. The transformers are also available in white or black.

Model Numbers	TE240-9DC-3-WH (European plug, white), TE240-9DC-3-BL (European plug, black), TU240-9DC-3-WH (U.K. plug, white), TU240-9DC-3-BL (U.K. plug, black)
Input Voltage	220-240 V $\sim$ 50/60 Hz
Output Voltage	9 V $\equiv$
Output Current	300 mA
Regulatory Approvals	CE
Environment	Ambient operating temperature: 0 °C to 40 °C (32 °F to 104 °F); Indoor use only.
Shipping Weight	0.184 kg (0.4 pounds)
Cord Length	190.5 cm (75 inches)

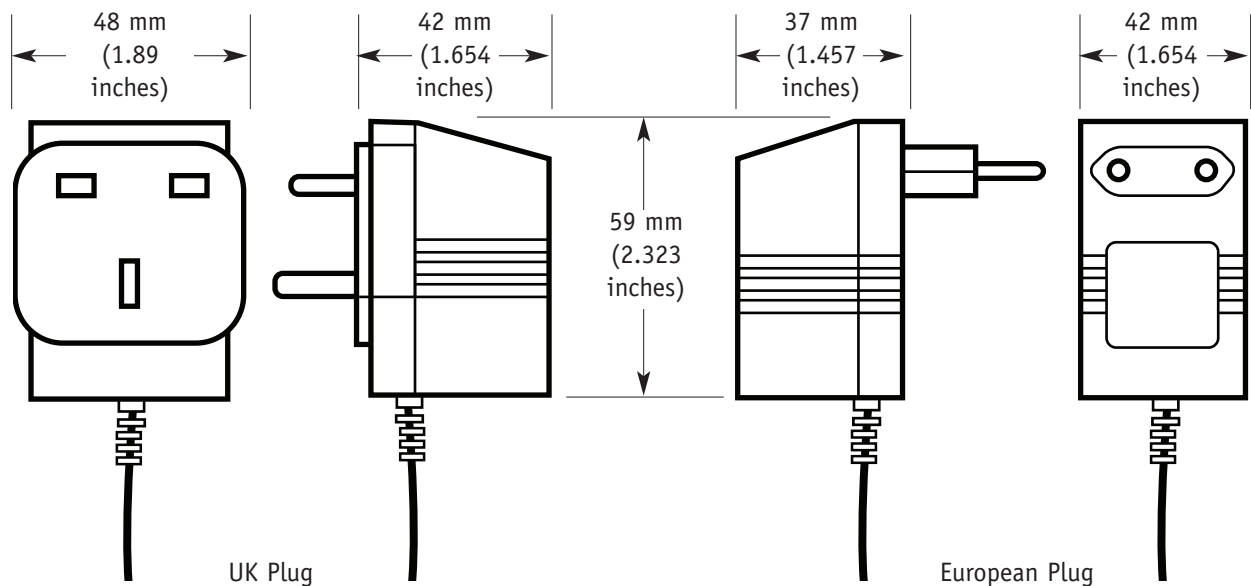


Figure 6 – Dimensions



# Sivoia QED<sup>®</sup>

# Interface for Sivoia QED®

## INTERFACE FOR HOMEWORKS® AND SIVOIA QED (MODEL# HWI-Q96)

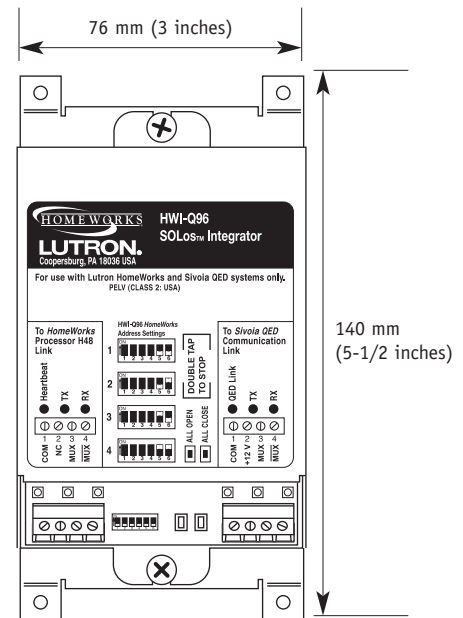
The interface allows the *HomeWorks* system to precisely control up to 96 individual *Sivoia QED* shades, blinds, draperies and curtains. Position can be set to open, closed, or anywhere in between.

### INSTALLATION INFORMATION

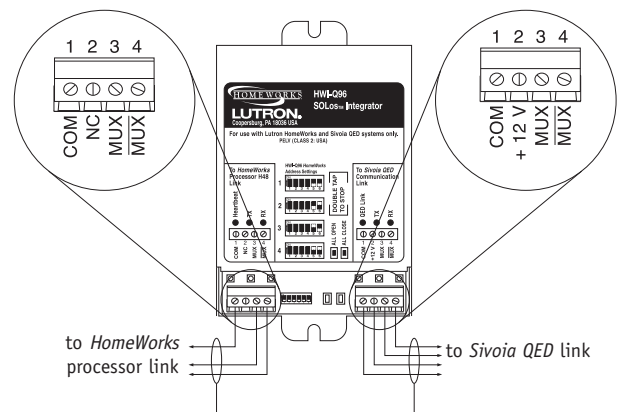
The HWI-Q96 interface can be mounted in a *HomeWorks* low-voltage enclosure in place of any contact closure interface board (HWI-CCI or HWI-CCO). If space does not permit an enclosure, the HWI-Q96 can be mounted as a stand-alone device.

### CONNECTION TO WIRED PROCESSOR

The interface connects to a configurable link configured for H48/Q96. Up to four interfaces can be connected one link. HWI-Q96 interfaces and H48 Dimmer Interface Boards can be used on the same link as long as their number does not exceed 4. The total number of lighting/shading zones cannot exceed 256 per processor.




**Interface for HomeWorks and Sivoia QED (HWI-Q96)**



**Figure 1 – HWI-Q96 Connections**



# Interface for Sivoia QED®

Model Number	HWI-Q96
Input Voltage	12 V  (from pin 2 of <i>Sivoia QED</i> link)
Regulatory Approvals	Class 2/PELV device
Environment	Ambient operating temperature: 0 °C to 40 °C (32 °F to 104 °F) Ambient operating humidity: 0-90% humidity, non-condensing. Indoor use only.
Low-voltage Wire Type	Two pair [one pair 1.0 mm <sup>2</sup> (18 AWG), one pair 1.0 to 0.5 mm <sup>2</sup> (18-22 AWG) twisted shielded] Class 2/PELV wire. For connection to <i>Sivoia QED</i> link, the 1.0 mm <sup>2</sup> (18 AWG) wire must be used for +12 V and Common. HWI-Q96 get its power from the <i>Sivoia QED</i> Link.
Low-voltage Wiring Configuration	Between processor and interface: Daisy-chain only. Termination required if total cable length exceeds 15 m (50 feet). Total length of wire on any link can not exceed 305 m (1,000 feet). Maximum of four HWI-Q96 and H48 Dimmer Interfaces per processor link configured for H48/Q96. Between HWI-Q96 and <i>Sivoia QED</i> Communication Link: Daisy-chain or home run. Maximum of 96 Sivoia QEDs per link. Total wire distance for the entire <i>Sivoia QED</i> system can not exceed 1220 m (4,000 feet).
Line-Voltage Connections	Between processor and HWI-Q96: One 4-pin removable terminal block. Terminal block will accept up to two 1.0 mm <sup>2</sup> (18 AWG) wires. Between HWI-Q96 and Sivoia QEDs: One 4-pin removable terminal block. Terminal block will accept up to two 1.0 mm <sup>2</sup> (18 AWG) wires.
Addressing	Via DIP Switch. Set DIP switches 5-6 to give HWI-Q96 a unique address from 1 to 4. DIP Switches 1-4 should always be in the down position. Counts as one address on the H48/Q96 link.
Diagnostics	Between processor and HWI-Q96: The HomeWorks® 'heartbeat' LED will be flashing to denote communication with the processor. If the LED is off, check the connections Between HWI-Q96 and Sivoia QEDs: The <i>Sivoia QED</i> TX and RX Communication LEDs are normally off. After limits have been set for each QED, Use the 'All Open' or 'All Closed' button and check the <i>Sivoia QED</i> Communications LEDs (TX and RX) for flashing after the button is pressed.
ESD Protection	Meets or exceeds IEC 61000-4-2 standard.
Surge Protection	Meets or exceeds ANSI/IEEE standard c62.41
Mounting	Mounts in the following enclosures: HWI-LV32-CE, HWI-LV17-CE, and HWI-ENC-CC
Shipping Weight	0.45 kg (0.99 pounds)

# Interface for Sivoia QED®

## Address Number and Switch Setting

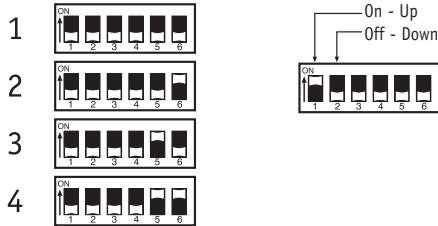


Figure 2 – DIP Switch Settings

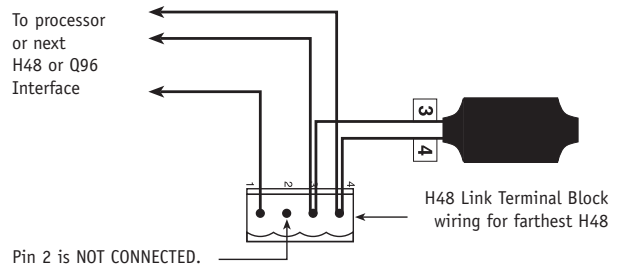


Figure 3 – LT1 Installation



### Sivoia QED® Features and Benefits:

- Ultra-quiet operation: will not exceed 44dBA measured 3 feet from the EDU.
- Smooth, silent starts and stops.
- Integrates with Lutron® Lighting control systems and other a/v equipment.
- Integrates with most outside systems such as home security or time clocks, without the use of external group controls or relay systems.
- Ten year power failure memory.
- Monitors shade position at all times.
- 24 VAC low-voltage power allows Sivoia QED to be installed by low-voltage contractors.
- Shades smoothly move in unison and stop in exact alignment within  $\pm 1.6$  mm (0.063 inches) accuracy.
- Optional infrared system provides easy, convenient control from anywhere in the room.

---

# Other Equipment

# Link Extender

Model	LUT-LINK-EXT: extends the total wire length allowed for use on the inter-processor and Module Interface links from 305 m (1,000 feet) to 610 m (2,000 feet).
Input voltage	100-120 V $\sim$ , 220-240 V $\sim$ 50/60 Hz
Regulatory approvals	UL, CSA, NOM, CE, C-Tick
Environment	Ambient temperature: 0 °C to 40 °C (32 °F to 104 °F) Ambient humidity: 0-90% humidity, non-condensing. Indoor use only.
Line-voltage	Use copper wire only, supply conductors 60/75 °C.
Low-voltage wire type	One pair twisted shielded 1.0 to 0.5 mm <sup>2</sup> (18-22 AWG) Class 2/PELV wiring.
Low-voltage wiring configuration	See figures 3, 4, page 12.3.
Low-voltage connections	One 4-pin removable terminal block. Each terminal will accept up to four 1.0 mm <sup>2</sup> (18 AWG) wires.
Addressing	Not required.
Diagnostics	LEDs provide diagnostics for troubleshooting communication on the links.
ESD protection	Meets or exceeds IEC 61000-4-2.
Surge protection	Meets or exceeds ANSI/IEEE standard c62.41.
Dimensions	197 mm (7-3/4 inches) x 127 mm (5 inches) x 64 mm (2-1/2 inches)
Mounting	Mounts on a standard 105 mm (4 inches) x 105 mm (4 inches) junction box. Lutron® backbox 241496 may be used.
Shipping weight	1.1 kg (2.425 pounds)
Using special cable	Special wire can be used to extend the total wire length on the inter-processor and Module Interface links from 305 m (1,000 feet) to 1220 m (4,000 feet) without the use of a Link Extender, and to 2240 m (8,000 feet) with the use of a Link Extender. Refer to HomeWorks® application note #62 for details and wire specifications.

# Link Extender

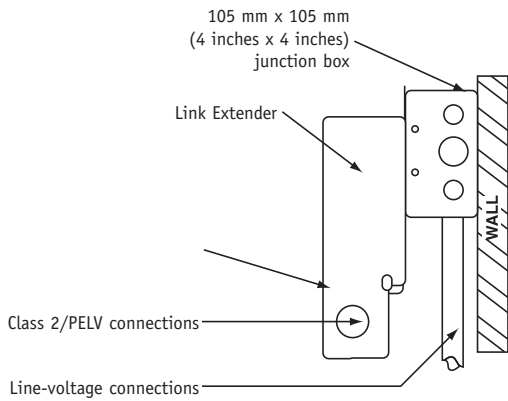


Figure 1 – mounting diagram

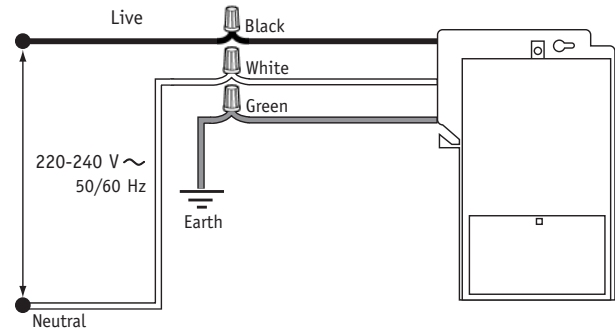


Figure 2 – line-voltage wiring diagram

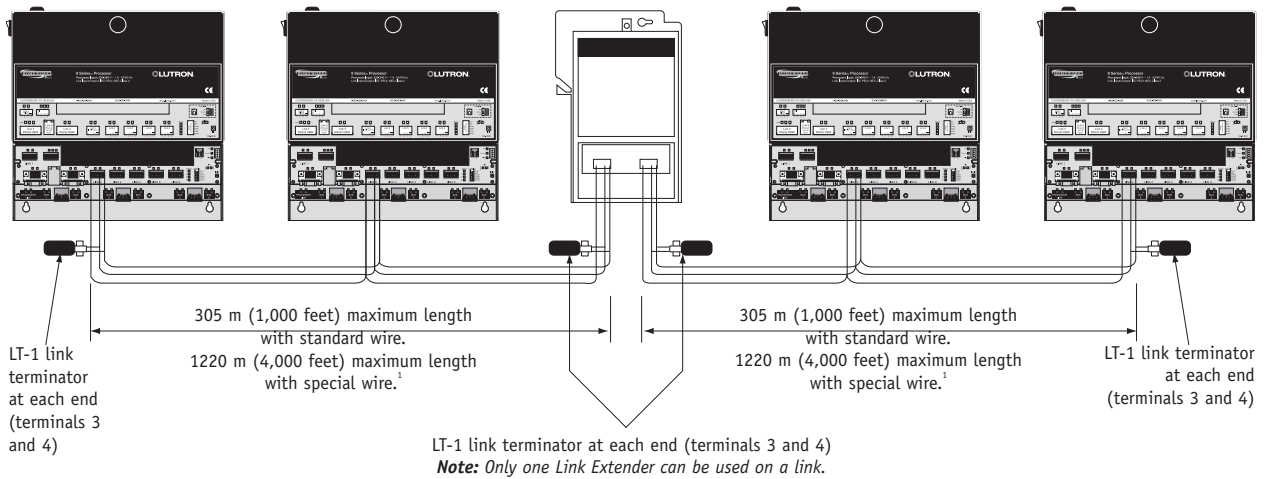


Figure 3 – inter-processor link wiring diagram with LUT-LINK-EXT

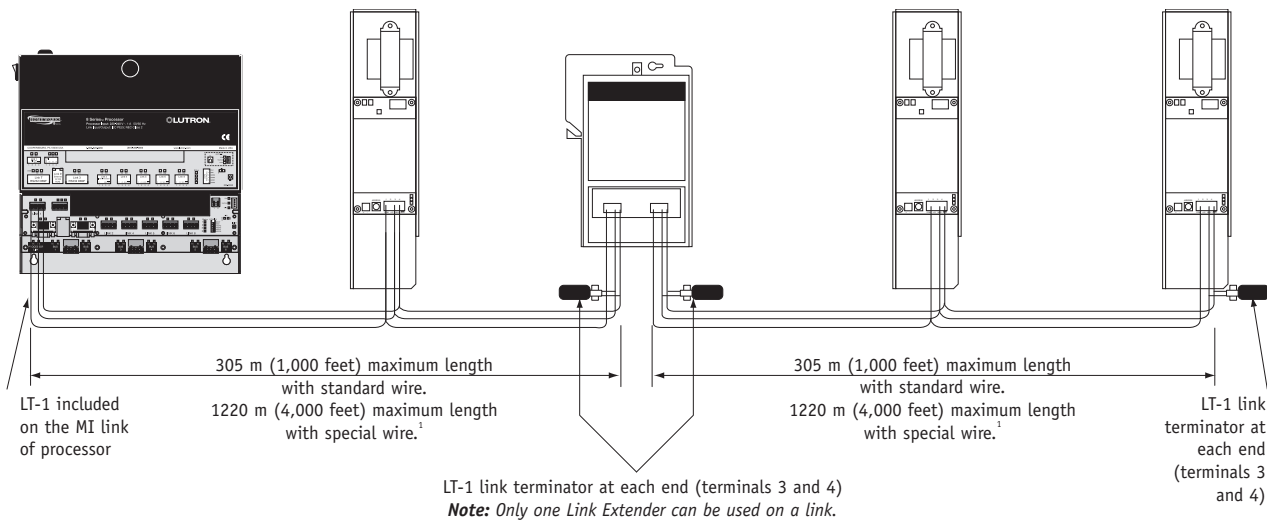


Figure 4 – Module Interface link wiring diagram with LUT-LINK-EXT

<sup>1</sup> For information on special wire, see HomeWorks® application note # 62.

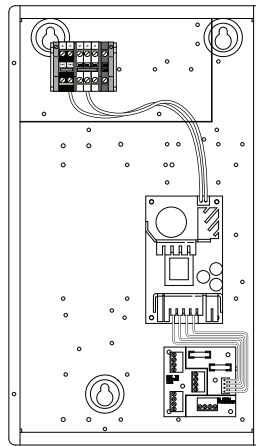
# Auxiliary Power Supplies

**Note:** HWI-PS-230 model has been obsoleted and should be replaced by the new PPS1- or PPS2-auxiliary power supplies.

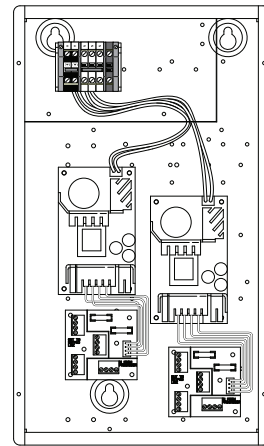
The auxiliary power supplies are additional 15 V power sources that are used to power additional keypads and contact closure interfaces when the power supply capacity of the processor is exceeded. A 4 Series P5 processor can power a maximum of 150 LEDs, and an 8 Series P5 processor can power a maximum of 350 LEDs.

## WALL-MOUNTED AUXILIARY POWER SUPPLIES

The wall-mounted auxiliary power supplies can power a maximum of 500 additional LEDs (PPS1) or 1000 additional LEDs (PPS2).



**PPS1-230-15DC-3A**



**PPS2-230-15DC-3A**

<b>Enclosure-Mounted Auxiliary Power Supplies</b>	
Model Number	PPS1-230-15DC-3A: Supports an additional 500 LEDs on a keypad link.  PPS2-230-15DC-3A: Supports an additional 1000 LEDs on a keypad link.
Input voltage	220-240 V ~ 50/60 Hz
Regulatory Approvals	CE
Line-Voltage Connections	Use copper wire only, supply conductors 60/75 °C. DIN rail-mounted terminal blocks for power supply feed located at top left corner of panel.
DIN Rail Terminal Blocks	Terminal blocks will accept one 1.0 to 2.5 mm <sup>2</sup> (18-10 AWG) wire or two 1.0 to 1.5 mm <sup>2</sup> (18-16 AWG) wires. Terminal blocks should be tightened to 0.40 to 0.57 n·m.
Output Voltage	15 V ===
Output Current	PPS1: 500 LEDs Maximum (3 A Maximum) PPS2: 1000 LEDs Maximum (2 Input/Output boards, 3 A Maximum each)
Fuse Rating	3.15 A 125 V
Dimensions	23 cm x 44 cm x 9.8 cm (9.055 inches x 17.323 inches x 3.858 inches)
Mounting	Enclosure may be surface-mounted or flush-mounted.
Construction	Enclosure: 16-gauge galvanized sheet metal (unpainted). Cover: Painted (black) metal cover with ventilation holes. Attach using four phillips-head screws.
Shipping Weight	5.9 kg (13.0 pounds)

# Auxiliary Power Supplies

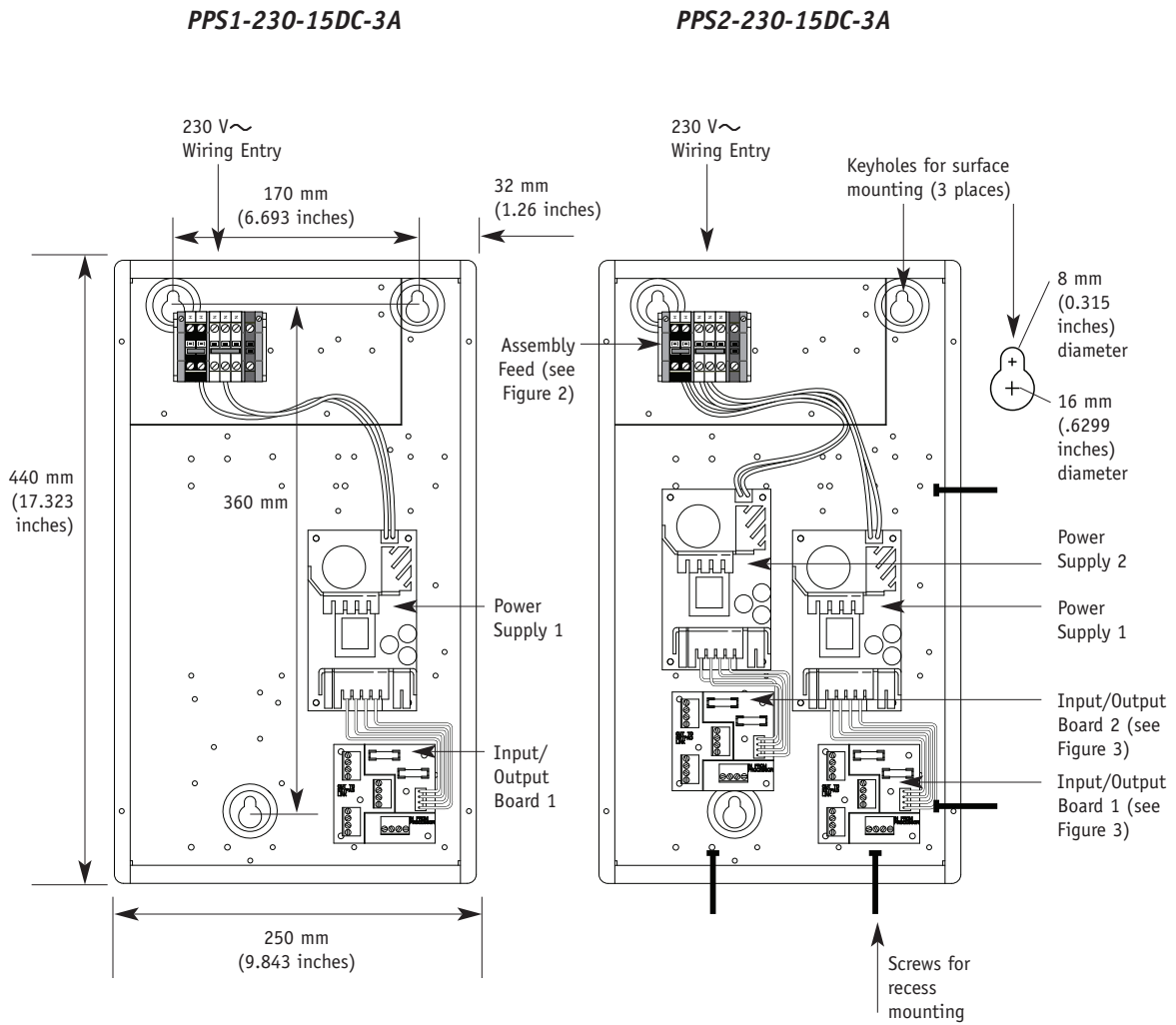
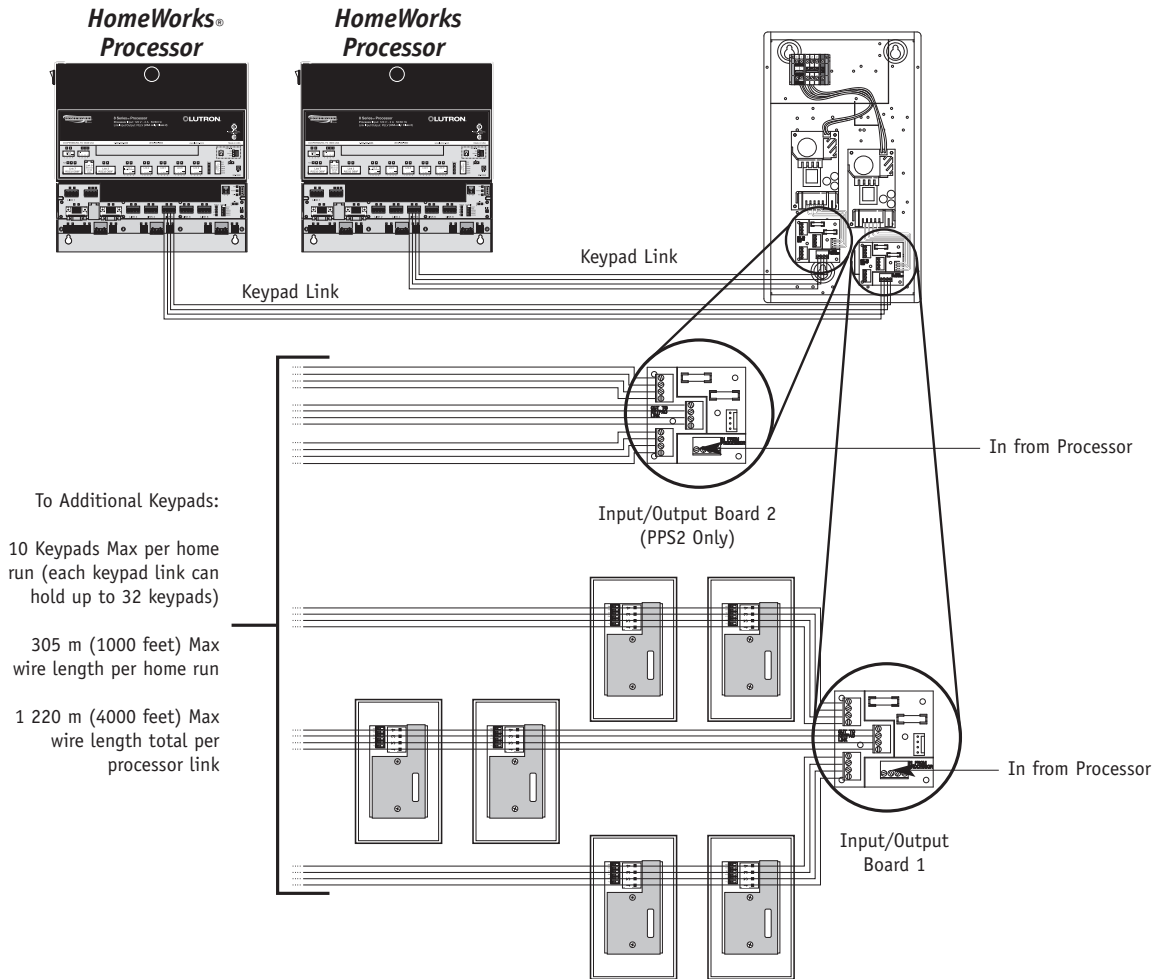
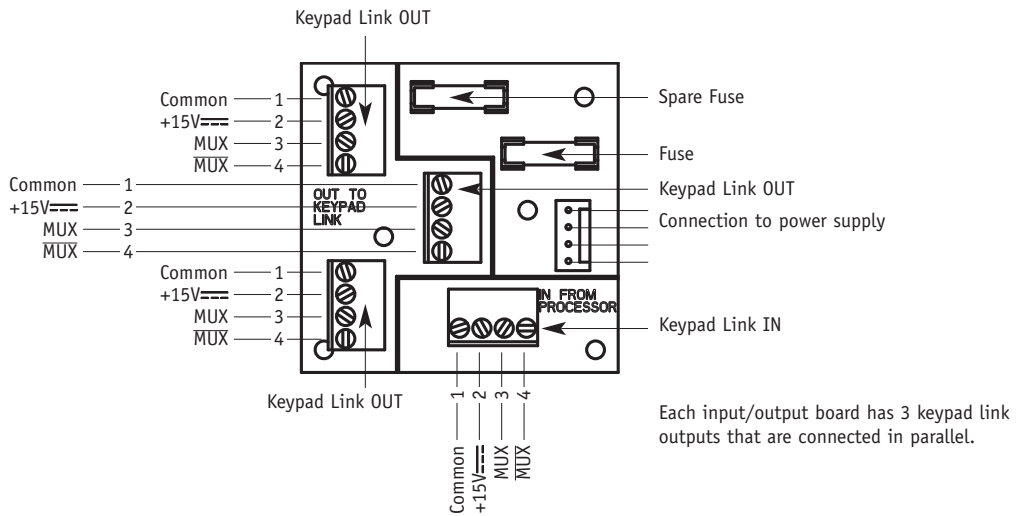


Figure 1 – PPS Dimensions and Mounting

# Auxiliary Power Supplies



**Figure 2 – PPS Low-voltage Wiring**



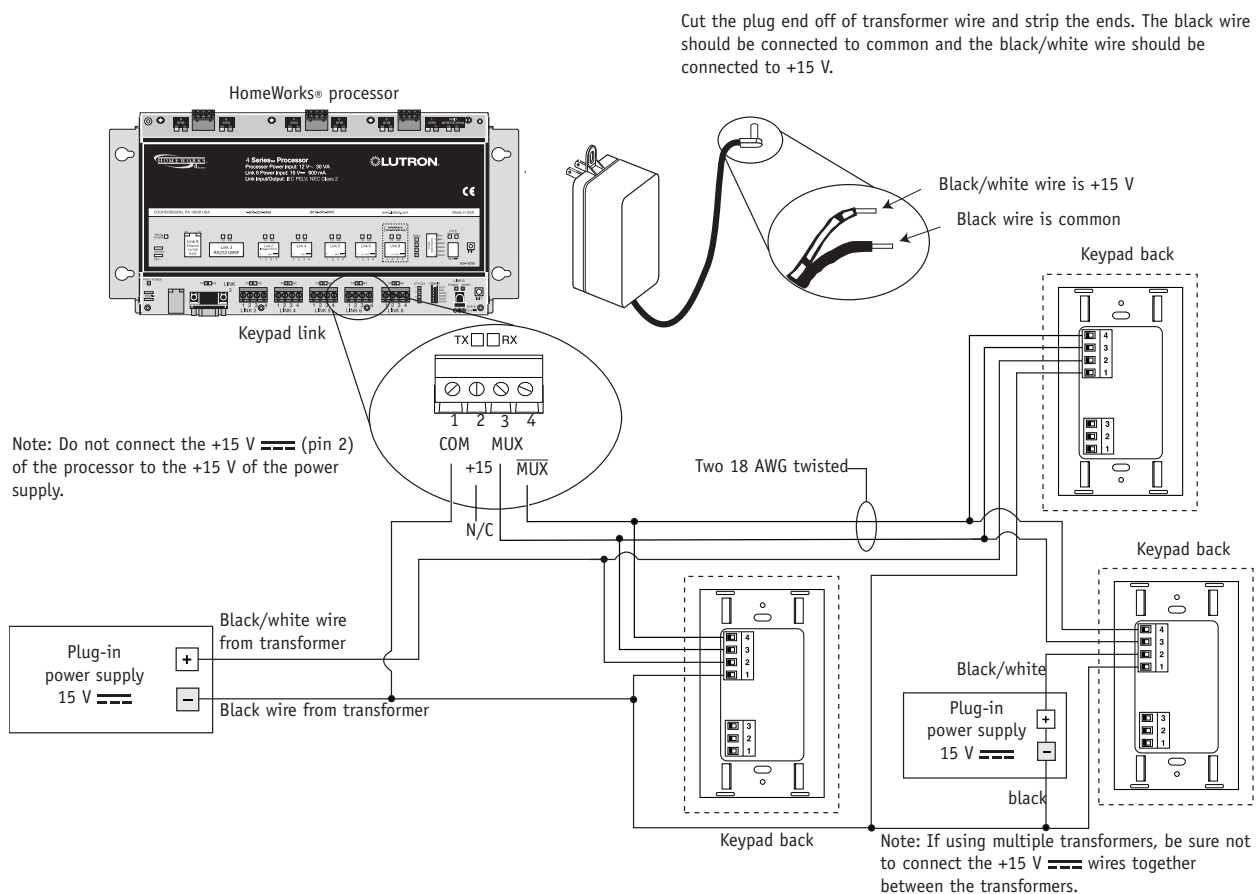
**Figure 3 – PPS Input/Output Board Wiring Detail**



# Auxiliary Power Supply - Plug-in Models

The plug-in power supply is a 15 V<sub>DC</sub> power source that can be used to power keypads and Contact Closure Interfaces. Each processor has a maximum quantity of LEDs it can power. Auxiliary power supplies are required if the maximum LED count is exceeded. Refer to page 5.34 for maximum capacities.

Models	TE240-15DC-9-BL: European-style plug. TU240-15DC-9-BL: UK-style plug.
Input voltage	220-240 V <sub>AC</sub> 50/60 Hz
Regulatory approvals	CE, C-Tick
Line-voltage connections	Plugs into standard power sockets.
Output voltage	15 V <sub>DC</sub>
Output current	900 mA maximum, powers 150 LEDs on the keypad link. See page 5.34 for LED counts for the different keypad and Contact Closure Interface models.
Dimensions	29 mm (1-1/8 inches) x 80 mm (3-1/8 inches) x 46 mm (1.785 inches)
Shipping weight	0.7 kg (1.5 pounds)



# Electronic Low-voltage Transformers

SELV-equivalent step-down transformer for halogen lamps is compatible with *Lutron's* leading or trailing edge 230 V ~ CE products. The transformers include short-circuit, thermal, and overload protection with self-resetting capabilities.

Models are available on with either terminal blocks or flying leads for the secondary output.

Models	60 Watt: ELVXF-60-L21-CE, ELVXF-60-L22-CE, ELVXF-60-T20-CE. 105 Watt: ELVXF-105-T20-CE.
Input voltage	230-240 V ~ 50/60 Hz
Regulatory approvals	CE, SEMKO EMC, ENEC
Environment	Ambient temperature: 10 °C to 50 °C (50 °F to 122 °F) Ambient humidity: Relative humidity less than 90% non-condensing.
Output voltage	11.7 V ~, 35 KHz, SELV-equivalent
Protection	Short-circuit, thermal, and overload protection with self-resetting capability.
Connections	Input screw terminal block accepts 2.5 mm <sup>2</sup> (10 AWG) wire maximum and output screw terminal block accepts 4.0 mm <sup>2</sup> (6 AWG) wire. Torque 0.34 n·m (3 inch-pounds). Flying leads are 2 x 0.75 mm <sup>2</sup> (18 AWG) PVC/PVC 105 °C wires 0.5 m (1.5 feet) long.
Standards	Safety: EN 61347.2.2 Performance: EN 61047 EMC: EN 55015 Transient: EN 61547 Harmonics: EN 61000.3.2
Mounting	Single screw
Shipping weight	0.14 kg (0.3 pounds)

# Electronic Low-voltage Transformers



## Dimensions

L: 150 mm (5.906 inches)

W: 42 mm (1.654 inches)

H: 32 mm (1.26 inches)

## 60 WATT ELECTRONIC LOW-VOLTAGE TRANSFORMER

- Input Power: 230-240 V  $\sim$   $\pm$  10% 50/60 Hz, at 60 W, 0.28 A.
- Output Power: 11.7 V  $\sim$  35 kHz, 10-60 W, SELV-Equivalent.

Terminal blocks on primary and secondary:  
ELVXF-60-T20-CE.

One pair of leads on the secondary: ELVXF-60-L21-CE.

Two pairs of leads (on the primary and secondary):  
ELVXF-L22-CE.

## 105 WATT ELECTRONIC LOW-VOLTAGE TRANSFORMER

- Loop-in/Loop-out terminals on the primary.
- Three secondary terminals.
- Input Power: 230-240 V  $\sim$   $\pm$  10% 50/60 Hz, at 105 W, 0.45 A.
- Output Power: 11.7 V  $\sim$  35 kHz, 36-105 W, SELV-Equivalent.

Terminal blocks on primary and secondary:  
ELVXF-105-T20-CE.

# Electronic Low-voltage Transformers

## ***Low-voltage transformers - product compatibility***

HWI 4U modules

HWI 4A modules

HWA-5E

HNA-5E

GXI-3\_\_\_-\_-CE-\_\_

NTGRX-ELVI-CE-WH

LP 4E modules

GRX-3\_\_\_-\_-CE-\_\_

NTGRX-PB-CE-WH

LP 4U modules

LP 4A modules

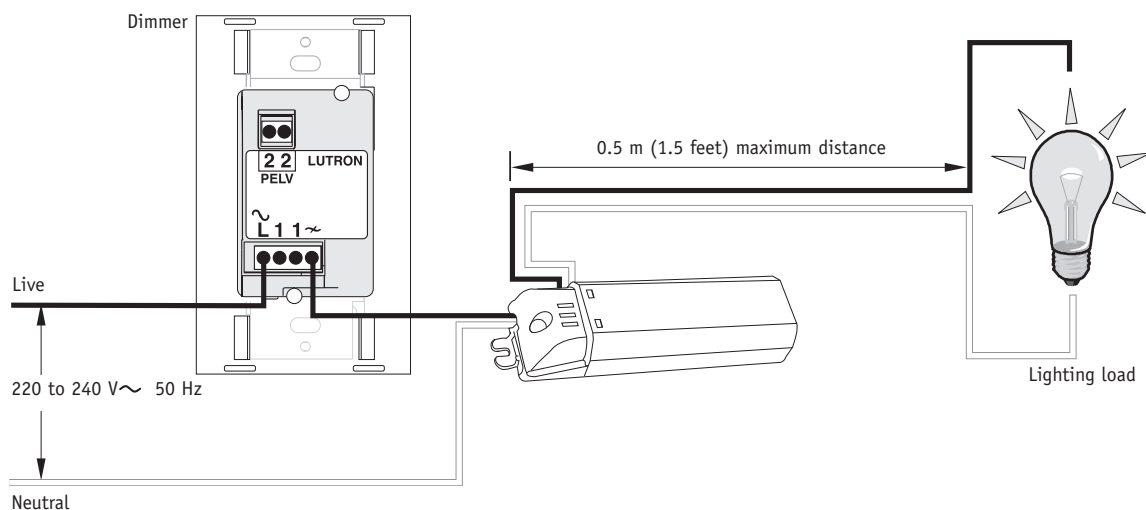
GP modules

HRI-45D1-1x

Note: Do not mix electronic and magnetic transformers on the same circuit.

## ***WIRING***

- Pull 2.5 mm<sup>2</sup> (10 AWG) CU 75 °C minimum wires for input connections.
- Keep the distance between the load and the transformer to a maximum distance of 0.5 meters (1.5 feet).

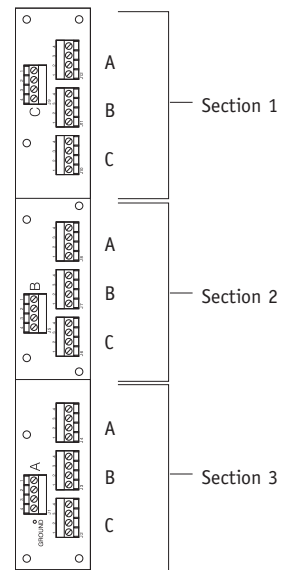


**Figure 1 – wiring diagram**

# Wire Landing Board

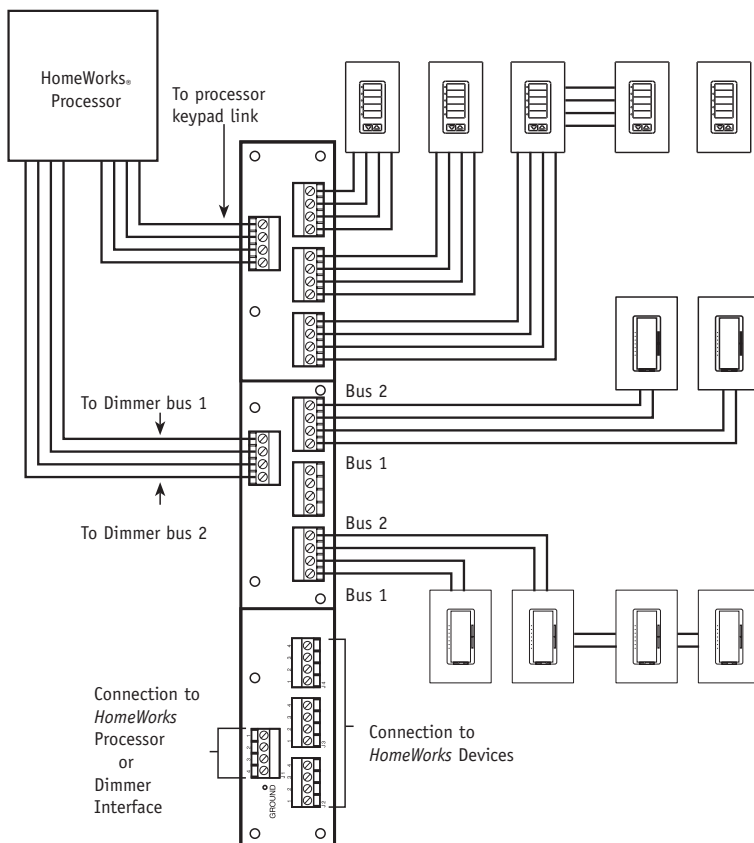
**WIRE LANDING BOARD**  
**(MODEL HWI-WLB)**

The Wire Landing Board is a wiring aid to help with wiring of keypads and Maestro® dimmers. Wire Landing Boards are installed in low-voltage enclosures.



**Wire Landing Board  
(HWI-WLB)**

Each section combines three input connectors A, B, C into one output connector.



**Figure 1 – wiring diagram**





# Colours and Finishes

# Colours and Finishes

HomeWorks® products are available in a variety of colours and finishes.

<b>GRAFIK Eye® and GRAFIK Integrale®</b>	
<b>Plastic</b>	white (WH)
	black (BL)
	beige (BE)
	ivory (IV)
	gray (GR)
	brown (BR)
	taupe (TP)
	sienna (SI) NEW
	almond (AL) NEW
	light almond (LA) NEW
<b>Metallic</b>	satin nickel (SN)
	bright nickel (BN)
	satin brass (SB)
	bright brass (BB)
	antique brass (QB)
	satin chrome (SC)
	bright chrome (BC)
	satin bronze (SZ)
	bright bronze (BZ)
	antique bronze (QZ)
	clear anodised aluminium (CLA)
	black anodised aluminium (BLA)
	brass anodised aluminium (BRA)
gold plated (AU)	

<b>seeTouch®, slim button, large button and 2-button Keypads</b>	
<b>Plastic</b>	white (WH)
	black (BL)
	beige (BE)
	ivory (IV)
	gray (GR)
	brown (BR)
	taupe (TP)
	sienna (SI) NEW
	almond (AL) NEW
	light almond (LA) NEW
<b>Metallic</b>	satin nickel (SN)
	bright nickel (BN)
	satin brass (SB)
	bright brass (BB)
	antique brass (QB)
	satin chrome (SC)
	bright chrome (BC)
	satin bronze (SZ)
	bright bronze (BZ)
	antique bronze (QZ)
	clear anodised aluminium (CLA)
	black anodised aluminium (BLA)
	brass anodised aluminium (BRA)
gold plated (AU)	



# Colours and Finishes

HomeWorks® products are available in a variety of colours and finishes.

<b>Signature Series™ Keypads</b>	
<b>Metal Finishes</b>	satin nickel (SN)
	bright brass (BB)
	bright chrome (BC)
	unfinished brass (UB)
	gold plated (AU)
	painted by customer (FP)
	white (WH) (Monterey only)

<b>Architrave™ Keypads</b>	
<b>Metallic</b>	white (WH)
	bright brass (BB)
	other metals are available on a custom basis

<b>Rania Lamp Dimmer</b>	
<b>Plastic</b>	arctic white (AW)
	mica (MC)

European-style keypads are available only in white (WH) and black (BL) plastic finishes. Bang & Olufsen compatible keypads are also available in satin nickel (SN).

<b>European-style Faceplates (replacement faceplates)</b>	
<b>Metallic</b>	satin nickel (SN)
	bright nickel (BN)
	satin brass (SB)
	bright brass (BB)
	antique brass (QB)
	satin chrome (SC)
	bright chrome (BC)
	satin bronze (SZ)
	bright bronze (BZ)
	antique bronze (QZ)
	gold plated (AU)

<b>Rania® RF Wall Dimmer International seeTouch® Keypad</b>	
<b>Plastic</b>	arctic white (AW)
	argentum (AR)
	mica (MC)
<b>Metallic</b>	satin nickel (SN)
	bright nickel (BN)
	satin brass (SB)
	bright brass (BB)
	satin chrome (SC)
	bright chrome (BC)
	antique bronze (QZ)
	antique brass (QB)
gold plated (AU)	

# Colours and Finishes

HomeWorks® products are available in a variety of colours and finishes.

Tabletop keypads are available only in white (SW) and black (MN) plastic finishes.

<b>Tabletop Faceplates</b> (replacement faceplates)	
<b>Plastic</b>	white (SW)
	black (MN)
<b>Metallic</b>	satin nickel (SN)
	bright nickel (BN)
	satin brass (SB)
	bright brass (BB)
	antique brass (QB)
	satin chrome (SC)
	bright chrome (BC)
	satin bronze (SZ)
	bright bronze (BZ)
	antique bronze (QZ)
	clear anodised aluminium (CLA)
	black anodised aluminium (BLA)
	brass anodised aluminium (BRA)
	gold plated (AU)



# Patents

These products may be covered by one or more of the following U.S. patents:

4,449,074 4,663,570 4,689,547 4,728,866 4,737,609 4,745,351  
 4,783,581 4,797,599 4,803,380 4,816,628 4,833,339 4,835,343  
 4,835,816 4,876,498 4,889,999 4,893,062 4,894,587 4,924,151  
 4,924,349 4,939,383 4,947,054 4,954,768 5,001,386 5,017,837  
 5,038,081 5,041,763 5,055,742 5,099,193 5,105,336 5,144,205  
 5,144,278 5,146,153 5,170,068 5,173,643 5,178,350 5,180,886  
 5,187,655 5,191,265 5,191,971 5,196,782 5,207,317 5,224,029  
 5,237,207 5,237,264 5,248,919 5,262,678 5,309,068 5,357,170  
 5,359,231 5,399,940 5,430,356 5,463,286 5,467,266 5,499,930  
 5,510,679 5,530,322 5,555,150 5,633,540 5,637,930 5,637,964  
 5,671,387 5,736,965 5,798,581 5,808,417 5,838,226 5,841,239  
 5,848,054 5,848,634 5,864,212 5,905,442 5,909,087 5,942,727  
 5,949,200 5,962,979 5,982,103 5,987,205 5,990,635 6,005,308  
 6,037,721 6,046,550 6,091,205 6,100,659 6,111,368 6,169,377  
 6,188,181 6,225,760 6,310,140 6,313,588

DES. 227,577 DES. 241,853 DES. 249,141 DES. 253,342 DES. 253,532  
 DES. 254,001 DES. 271,373 DES. 285,066 DES. 287,242 DES. 301,304  
 DES. 302,543 DES. 302,544 DES. 303,657 DES. 303,658 DES. 306,853  
 DES. 308,647 DES. 310,349 DES. 311,170 DES. 311,371 DES. 311,382  
 DES. 311,485 DES. 311,678 DES. 313,738 DES. 316,847 DES. 317,593  
 DES. 319,429 DES. 325,567 DES. 325,728 DES. 327,255 DES. 335,282  
 DES. 335,867 DES. 336,744 DES. 337,755 DES. 339,326 DES. 342,234  
 DES. 344,068 DES. 344,264 DES. 353,798 DES. 364,141 DES. 365,264  
 DES. 370,663 DES. 378,814 DES. 387,736 DES. 389,461 DES. 389,805  
 DES. 391,924 DES. 395,037 DES. 396,448 DES. 404,013 DES. 412,491  
 DES. 412,315 DES. 421,246 DES. 421,399 DES. 422,567 DES. 422,969  
 DES. 428,855 DES. 431,199 DES. 436,579 DES. 436,930 DES. 437,585  
 DES. 437,834 DES. 439,220 DES. 442,723 DES. 442,558 DES. 450,043  
 DES. 453,742 DES. 456,783 DES. 457,863 DES. 461,782 DES. 462,322  
 DES. 463,382 DES. 465,460 DES. 465,770 and corresponding foreign patents.

These products may be covered by one or more of the following U.K. patents:  
 2190804; 2182493; 0293569; 0427709; 2225872B; 0341805; 2221345B;  
 2251727B; 2239568; 2246034; 2234862B; 0531079; 0587878; 0637401;  
 EP 95906117.7; 2326768;

and by one or more of the following design registrations:  
 1048019; 1048020; 1048021; 1048792; 1048794; 1048793; 1045560;  
 1055178; 2001301; 1056587; 2021252; 2023658; 2023659; 2023660;  
 2028662; 2058358; 2063408; 2063409; 2063410; 2083226; 2083227;  
 2083228; 2083229; 2083230; 2083231; 2083232; 2083233; 2083234;  
 2083235; 2084666; 2084667; and corresponding patents of other countries.  
 US and foreign patents pending.

European Community: Lutron; Euro Maestro; GRAFIK; GRAFIK Eye;  
 GRAFIK Integrale; Hi-lume; Homeworks; Homeworks and Design; Lyneo;  
 Milenya; Nova T☆; RadioRa; Rania, RTISS; RTISS Equipped & Design;  
 Seetouch; Sivoia QED; Softswitch; Softswitch; Solina; Spacer; Sunburst logo  
 and Telume are registered trademarks of Lutron Electronics Co., Inc.

U.S.: Lutron, Ampion, Ariadni, Attaché, Aurora, Centurion, Claro, Credenza,  
 Dimming by Lutron, Diva, Earn & Learn, Earn & Learn Express, Euro Maestro,  
 Fandial, Glyder, GRAFIK Eye, GRAFIK 6000, Hi-lume, HomeWorks, Hyperion,  
 Luméa, Luméa 2, Lutron Dimmers Save Energy, Maestro, microWATT, Nova,  
 Nova T☆, Orion, Paesar, PerSONNA, Powerdial, RadioRA, Save Energy and  
 design, Sivoia, Skylark, Solaris, Spacer, Speedial, the Sunburst logo, Telume,  
 T☆, The Ultimate Home Theater Experience, The Ultimate Home Theater and  
 Design, Toggler, Tu-Wire, Vareo, Versaplex, and US Trademarks 1,617,349;  
 1,624,489; 1,624,490; 1,626,714, and 1,638,913  
 are registered trademarks of Lutron Electronics Co., Inc.

U.S.: Architrave, Athena, Classico, Designer, Digital microWATT, Dim-N-Glo,  
 Diva Duo, Eco-10, FASS, Faedra, FASS, FasTrak, Favorite Scene, GRAFIK 5000,  
 GRAFIK Eye Designer, GRAFIK Eye Liaison, GRAFIK Integral, hand, Harmony,  
 Hi-lume Compact, Hi-lume Compact SE, Hi-Power 2·4·6, Liaison, LuMaster,  
 Lustra, Maestro Duo, microOS, microPS, microWATT-SC, Millennium, NeTwork,  
 Omnislide, One Spec, Piedra, Pre-Pack, RadioTouch, Ranax, RTISS, Satin  
 Colours, seeTouch, Serena, Softswitch, Spacer System, Sunata, Symphony,  
 TapSwitch, Viseo, Vibrato, Zone Capture and 2Link are trademarks of Lutron  
 Electronics Co., Inc.





## **WORLD HEADQUARTERS**

Lutron Electronics Co., Inc.  
7200 Suter Road  
Coopersburg, PA 18036  
United States  
Tel: +1.610.282.3800  
Fax: +1.610.282.1243

## **CUSTOMER SERVICE/ORDERING**

UK +44.(0)20.7702.0657 – 09.00 - 18.00 GMT  
USA +1.610.282.3800 – 08.00 - 20.00 EST

## **CUSTOMER SERVICE/E-MAIL**

[custsvc@lutron.com](mailto:custsvc@lutron.com)

## **TECHNICAL SUPPORT & SERVICES**

UK +44.(0)20.7702.0657 – 09.00 - 18.00 GMT  
USA +1.610.282.3800 – 24 hours/7 days

## **INTERNET**

[www.lutron.com/europe](http://www.lutron.com/europe)

## **LUTRON SALES OFFICES**

### **European Headquarters**

United Kingdom	Tel: +44.(0)20.7702.0657	Fax: +44.(0)20.7480.6899	FREEPHONE (UK) 0800.282.107
France	Tel: +33.(0)1.41.05.42.80	Fax: +33.(0)1.41.05.01.80	FREEPHONE 0800.90.12.18
Germany	Tel: +49.(0)30.9710.4590	Fax: +49.(0)30.9710.4591	FREEPHONE 00800.5887.6635
Italy			FREEPHONE 800.979.208
Spain-Barcelona	Tel: +34.93.496.57.42	Fax: +34.93.496.57.01	FREEPHONE 0900.948.944
Spain-Madrid	Tel: +34.91.567.84.79	Fax: +34.91.567.84.78	FREEPHONE 0900.948.944

### **Worldwide Headquarters**

USA	Tel: +1.610.282.3800	Fax: +1.610.282.1243
Dubai	Tel: +971.4.299.1224	Fax: +971.4.299.1223

### **Asian Headquarters**

Singapore	Tel: +65.6220.4666	Fax: +65.6220.4333	FREEPHONE 800.120.4491
Hong Kong	Tel: +852.2104.7733	Fax: +852.2104.7633	FREEPHONE 800.901.849
China, Beijing	Tel: +86.10.5877.1818	Fax: +86.10.5877.1816	FREEPHONE 10.800.712.1536
Japan	Tel: +81.3.5575.8411	Fax: +81.3.5575.8420	
China, Guangzhou	Tel: +86.20.2885.8266	Fax: +86.20.2885.8366	FREEPHONE 10.800.120.1536
China, Shanghai	Tel: +86.21.6288.1473	Fax: +86.21.6288.1751	FREEPHONE 10.800.120.1536